

	UHV Approval Test: AML Stepper Motor	DCC Number: E050105-00-X
		Date Prepared: 3/30/2005

Originator	Cognizant Engineer	Ext./Phone#	Project	Account Number
Dennis Coyne	Dennis Coyne	#2034	LIGO	NSFLIGO.FY02CA-LIGO.PRLAS-5.16

Dwg/Part Number	Rev	Part Description	Serial Number	Qty
AML C17.2		UHV Caompatible Stepper Motor manufactured by AML, model C17.2	unit marked M002-016	1

**Used In (next higher assembly):** TBD – this is a test to qualify this design/component/materials/processing for use in LIGO UHV systems

Vendor Name	PO/Contract Number
AML	?

**Data Package, Receiving/Inspection Remarks:**

Inspection Required Y/N	Visual Damage Y/N	Comments	Name/ Initials	Date Comp.
Y	N	No certifications, calibration or test reports were provided; only a user manual which is attached to this traveller. The unit was wrapped in two layers of foil and two layers of a polymer bag and marked with a warning label that it is clean and not to be exposed or touched except with proper cleanroom procedures.	D. Coyne & R. Taylor	3/31/2005

**Process Flow:**

#	Operation	Start Date	Work Area	Instructions	Name/ Initials	Date Comp.
1	Preparation		CIT	Remove the plastic wire wraps carefully. Do NOT clean the component; This component comes from the manufacturer already cleaned for UHV service.	R. Taylor	04-04-05
3	Vacuum Bake		CIT	per E960022-B to a temperature of 200C for 48 hrs. We are not going to use the self-heat feature of the motor at this time. N.B.: Take outgassing measurements during cool down	R. Taylor	04-07-05

N.B.: A copy of this traveller must be submitted to the DCC each time the original is shipped with the associated part(s) and when the traveller has been completed.

#	Operation	Start Date	Work Area	Instructions	Name/ Initials	Date Comp.
				at approximately the following temperatures: 100C, 60C, 35C and 25C		
4	Control Point		NA	Review/approve RGA scan # _____  Attach the RGA scans to this traveller.	D. Coyne	
5	Wrap & Tag vacuum clean parts per E960022-B		CIT	Wrap (UHV foil) and bag (CP Stat or equiv.) per E960022.	R. Taylor	04-12-05
6	Test in Optical Contamination Cavity		CIT	Test in Optical Contamination Cavity with high irradiance (1064 micron wavelength) per E960022-B  Attach the total loss and absorption loss versus time plots to this traveller.	L. Cardenas	
7	Control Point		CIT	Review/approve total loss over time and absorption loss over time. Note here if acceptable for adv. LIGO use.	D. Coyne	
8	Wrap & Tag vacuum clean parts per E960022-B		CIT	Wrap (UHV foil) and bag (CP Stat or equiv.) per E960022-B	L. Cardenas	
9	Deliver/File paperwork		CIT	Make 2 copies of the Traveler. File one copy with the DCC. Return parts and original traveler to Dennis Coyne <b>Note: Ship original traveler with these parts.</b>	L. Cardenas	

END:

**Special Instructions (Handling/Packaging Constraints, Remarks, etc.) or Notes:**

N.B.: A copy of this traveller must be submitted to the DCC each time the original is shipped with the associated part(s) and when the traveller has been completed.

Do not clean this component. The stepper motor comes from the manufacturer ready for vacuum baking.

Photo of the stepper motor:



N.B.: A copy of this traveller must be submitted to the DCC each time the original is shipped with the associated part(s) and when the traveller has been completed.

Materials used in the AML stepper motor assembly (as far as we know):

- Silicon Nitride (ceramic) balls in bearings
- Stainless Steel (bearing cage & race)
- self-coloured polyimide (electrical insulation)
- PEEK (electrical insulation)
- metal surfaces are etched & coated with DLC (Diamond-Like Coating)
- Copper (wiring)
- FEP (power lead insulation)

Dimensions of this unit (C17.2):

- frame size 17 (42 mm x 42 mm)
- height (body) is 47 mm
- overall height with shaft is 70 mm
- weight is 320 g (manufacturer spec)

Suitable for use in vacuum below  $1e-10$  mB =  $0.8e-10$  torr (manufacturer spec)

N.B.: A copy of this traveller must be submitted to the DCC each time the original is shipped with the associated part(s) and when the traveller has been completed.

VTS



## Third generation UHV Stepper Motors

### Models C17.1 and C17.2

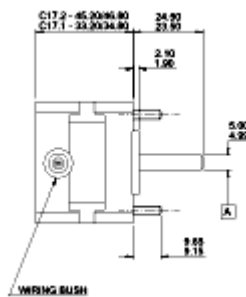

(dimensions in mm: fixings similar to B17)

The C17.1 UHV-compatible stepper motor has 50% more output torque than the B17.1 motor it replaces, for a very small increase in overall size. The efficiency has been optimised so that the temperature rise is reduced at all power outputs and consequently outgassing is significantly less. The C17.2 permits a convenient upgrade for applications where more torque is required.

### features

- Significantly higher torque. Drop-in replacement for B17.1 in most cases, resulting in significantly reduced gas load for the same power output..
- Easy upgrade from C17.1 to C17.2 for higher power: only 12mm additional space is required.
- Proven technology: similar AML motors have been in constant use since 1986.
- Open construction with all internal spaces ventilated.
- Very low particulate generation due to the absence of sliding metal contacts.
- Suitable for use below  $1 \times 10^{-10}$  mB.
- Bakeable to 200°C.
- Suitable for use at 77K.

- Warranty returns are less than 0.2%
- Hybrid ceramic bearings for long life and reduced friction after multiple bakeouts.
  - Greatly reduced outgassing and temperature rise due to advanced design, materials, surface finish and construction.
  - All insulating materials are self-coloured polyimide or PEEK, with exceptional outgassing and insulating performance.
  - Surfaces are etched and coated with DLC for increased emissivity and reduced outgassing..
- Radiation-hard versions available.
  - Electrical connections reduced to only 6 durable polyimide film-coated wires.
  - Simplified connection with MLF12 or MLF18 bakeable lead, feedthrough and internal connector. Motors can be supplied pre-wired to internal connectors.
  - Dedicated drive, AML type SMD2 is available.
  - Standard motors are normally available from stock



[More Detail](#) 



Copyright © VTS Inc. 2002  
Last Update: 02/06/18



VTS



## Third generation UHV Stepper Motors Models C17.1 and C17.2 Specification

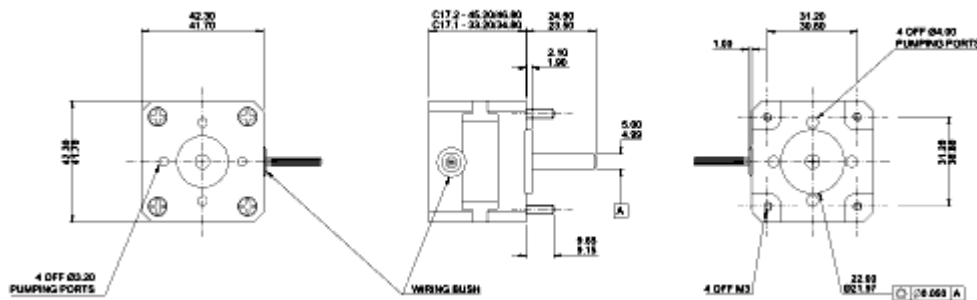

(dimensions in mm)

### Performance Curves.

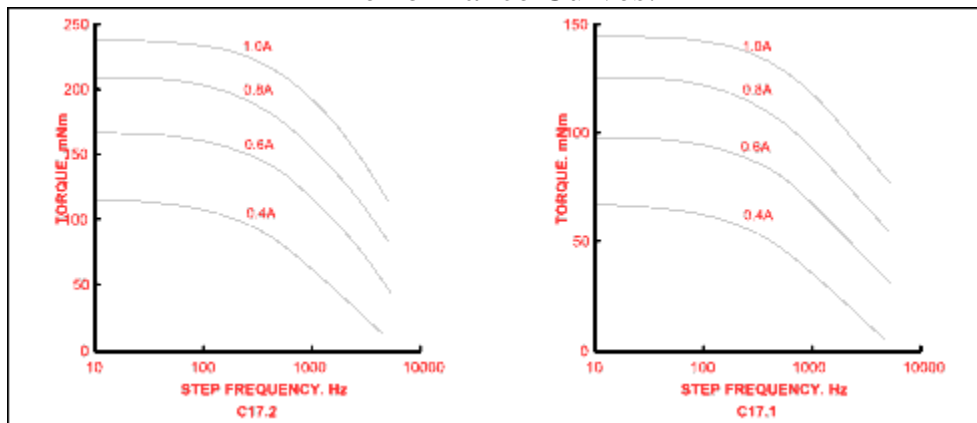

The performance shown on the graphs above was obtained using an SMD2 drive operating with standard settings for step division. SMD2 is a switch-mode current-regulating drive with a nominal source of 67volts, optimised for use

with vacuum stepper motors. Different drives will produce different speed/torque curves. Drives capable of producing a total phase current of more than 1A RSS (root sum of squares) may damage the insulation, even if the current is claimed to be adjustable. Drives with significantly lower source voltages will result in poor high-speed performance. Sufficient data are given below for drive selection.

---

<b>Step Angle:</b> 1.8°	<b>Bakeout Temperature:</b> 200°C
<b>Step Angle Tolerance:</b> 5% (unloaded)	<b>Operating Temperature:</b> -196°C to +175°C
<b>Resistance per Phase:</b> 4 ohms(C17,1) 6 ohms(C17,2)	<b>Weight:</b> 210g(C17.1) 320g(C17.2)
<b>Inductance per Phase:</b> 4.5mH(C17.1) 11mH(C17.2)	<b>Power Leads:</b> 0.6mm diam (Cu+polyimide+FEP)
<b>Detent Torque:</b> 5mNm(C17.1) 7mNm(C17.2)	<b>K-type T.C. leads:</b> 0.2mm diam (polyimide)
<b>Rotor Inertia:</b> 30g cm <sup>2</sup> (C17.1) 55g cm <sup>2</sup> (C17.2)	<b>Lead Length:</b> 1.35m
	<b>Shaft-end-float:</b> 0.2 to 0.4 mm

---

## INSTALLATION / APPLICATION NOTES

The screws are fitted with metered torque. Do not disturb. Do not drop, demagnetise, disassemble, modify, touch or overheat the motor or allow particles to enter the bearings or pumping ports. AML will supply modified-shaft motors.

Identify the two power windings with a resistance meter. Reverse the connection of either winding to reverse rotation. The thermocouple alumel ( wire (negative) is magnetic. A small magnet is provided for identification. AML will pre-wire motors to

The bearings are silicon nitride balls in stainless steel with maximum static axial or radial load of 15kg.

Design mechanisms with balanced rotating loads and/or friction to maintain position with zero (or reduced) phase current for minimum outgassing. Use ministep only to smooth transitions: increase resolution by reduction gearing

Ensure ice cannot form in the motor if

MLF12VCF or MLF18 VCF  
connectors at low cost.

The shaft end-float-control  
compression spring is fully exercised  
with an axial force of 3kg toward the  
rear of the motor. In linear  
mechanisms use gravity and/or apply  
an opposite axial pre-load to avoid  
adding end-float to backlash.

testing at low temperature in air.  
Avoid thermal shocks e.g. plunging in  
liquid nitrogen.

Motors are supplied pre-baked at HV.  
They will adsorb water in storage and  
handling. A 24-hour self-bake by  
SMD2, with an adequate pump, will  
achieve UHV-compatibility.

AML pursues a policy of continuous development and reserves the right to amend  
specifications without notice  
All specifications are typical. E&OE

## Ordering information

- C17.1**    • Add suffix **R** for radiation hardness to  $1 \times 10^7$   
or        Sv
- C17.2**    • Add suffix **X** for shaft modification e.g.  
cross-hole flat - provide a sketch.

## Related products

- [SMD2](#)    • Dual UHV Compatible Stepper Motor Drive
- [FSTxx](#)   • UHV Fast Long Travel Linear Sample  
Transporter
- [MIF18](#)   • Connection kit for three motors

[Overview](#) 



Copyright © VTS Inc. 2002  
Last Update: 02/06/18





[About us](#)
[Products](#)
[Special offers](#)
[News](#)
[Surplus](#)

Reuterweg 65 • D-60323 Frankfurt/M • Tel +49 (0)69-720040 • F 720400 • [info@tectura.de](mailto:info@tectura.de)

## Content:

- [UHV Stepper Motor](#)
- [Specifications](#)
- [Stepper Motor Drives](#)

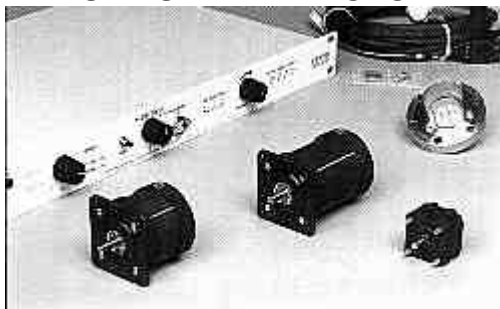
### UHV STEPPER MOTOR



copyright AML

The electromechanical efficiency of AML motors have been optimised so that continuous running UHV at high torque and low outgassing is possible. They are particularly suitable for beam-ch and fast sample-translation applications.

- Proven technology; similar AML motors have been in constant use since 1986.
- All insulating materials are self-coloured polyimide or PEEK, with exceptional outgassing insulating performance.
- Improved hybrid ceramic bearings for longer life and reduced friction after multiple bakes.
- Electrical connections reduced to only 6 durable polyimide film-coated wires.
- Simplified connection with MLF12 bakeable lead feedthrough and connector kit. (Not included)
- Greatly reduced outgassing and temperature rise due to improved design, materials, surface finish and construction.
- Surfaces are etched and coated with a matt black diamond-like film for increased emissivity and reduced outgassing.
- Continuous running in vacuum at high torque and step rates with SMD2 drive.
- Suitable for use below  $1 \times 10^{-10}$  mB.
- Bakeable to 200°C.
- Suitable for use at 77K.
- Radiation-hard versions to order.
- Selected motors with 30% increased torque available from stock.
- Open construction with all internal spaces ventilated.
- Very low particulate generation due to the absence of sliding metal contacts.

### SPECIFICATION

The performance shown on the graphs above was obtained using an SMD2 drive operating w standard settings for step division. The winding temperature increase is representative of a ty installation and was obtained from a motor mounted on a LCT100 slide mechanism bolted to : CF200 flange. A motor suspended in vacuum with no heatsink will reach an equilibrium windi temperature of 175°C at 1 amp. Chamber wall temperature was 22°C in all cases.



copyright AML

	B14.1	B17.1	B23.1	B23.2
Step angle	1.8°	1.8°	1.8°	1.8°
Step angle tolerance	5%	5%	5%	5%
Phase Resistance	3 ohms	4 ohms	10 ohms	15 ohms
Phase Inductance	3.25 mH	3.75 mH	25 mH	42 mH
Holding torque (2 x 1 A)	40 mNm	80 mNm	0,4 Nm	0,7 Nm
Detent torque	3 mNm	5 mNm	0,03 Nm	0,05 Nm
Rotor inertia	10 g cm <sup>2</sup>	18 g cm <sup>2</sup>	100 g cm <sup>2</sup>	200 g cm <sup>2</sup>
Bakeout Temperature	200°C	200°C	200°C	200°C
Operating Temperature	<-196 to 175°C	<-196 to 175°C	<-196 to 175°C	<-196 to 17
Weight	150 g	165 g	680 g	1 kg
Power leads OFHC Cu + Polyimide + FEP	0.6 mm	0.6 mm	0.6 mm	0.6 mm
K-type T/C leads (Polyimide)	0.2 mm	0.2 mm	0.2 mm	0.2 mm

Leads are 1.35 m long. Bearings are silicon nitride balls running in stainless steel cage and ra Wiring bushes are PEEK. The mounting studs are assembly screws and must not be remove Several variations of standard motors are available: lead-length variation, radiation-hardness : <sup>9</sup>Rad, +30% torque selection and shaft variations (no flats or extensions), rear shaft. rear wire Not all variations available with specific motor types.

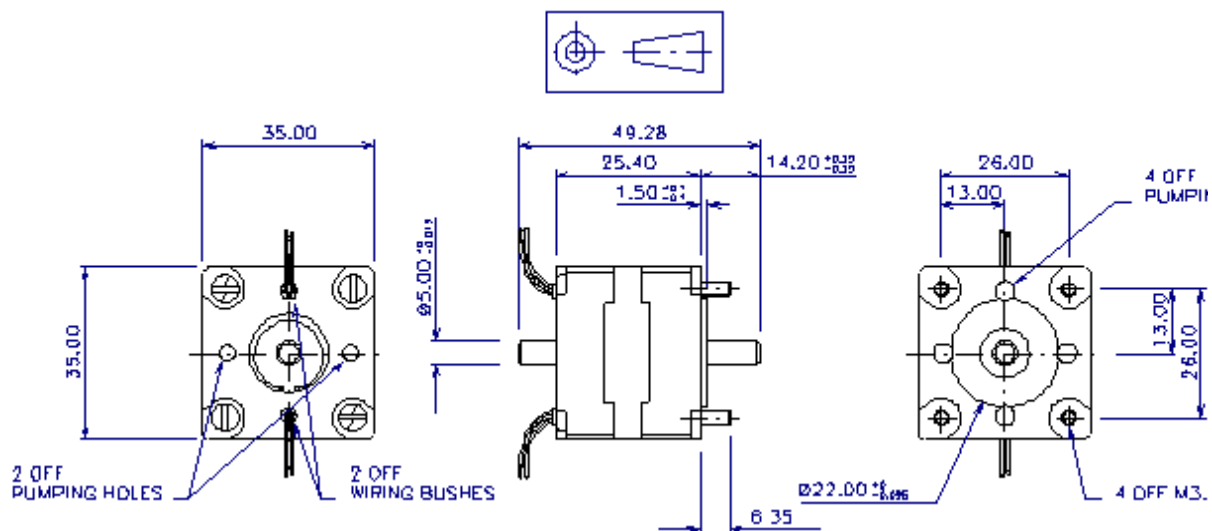

B14.1

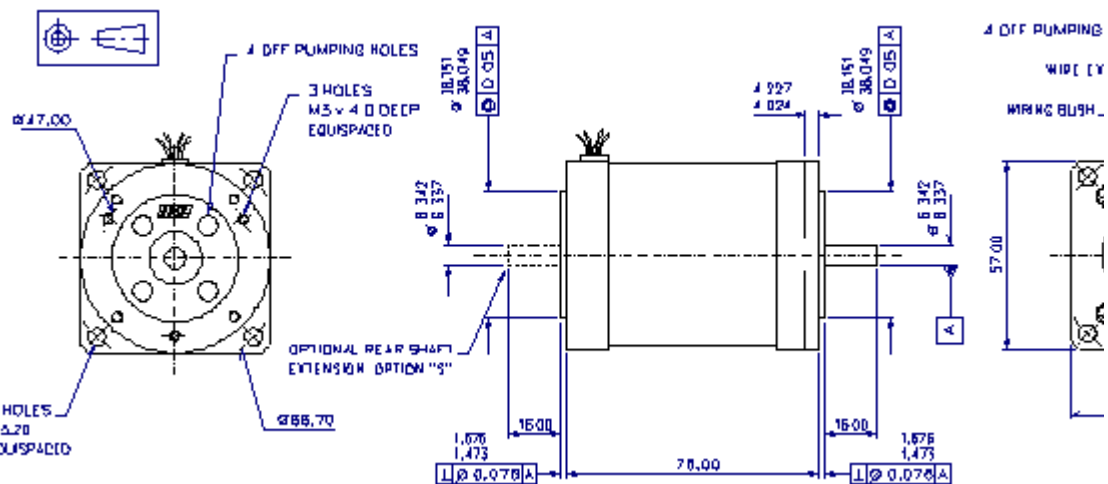

B23.2

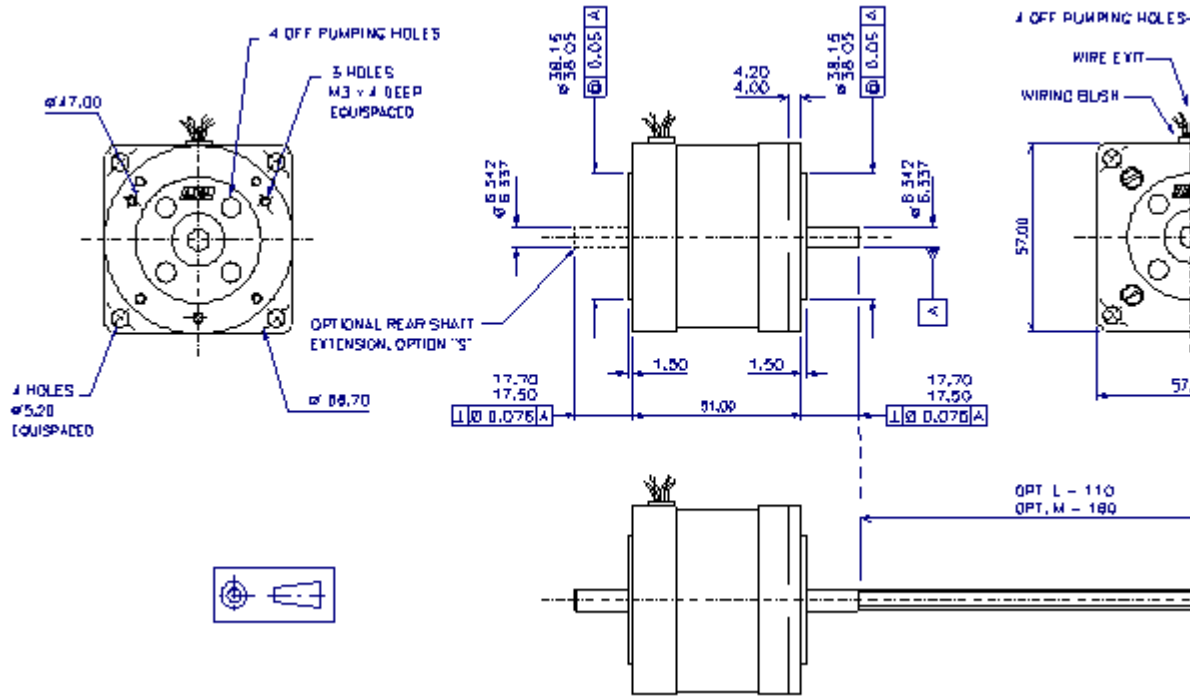

B23.1

## Stepper Motor Drives

### Stepper Motor Drives SMD1, SMD1M

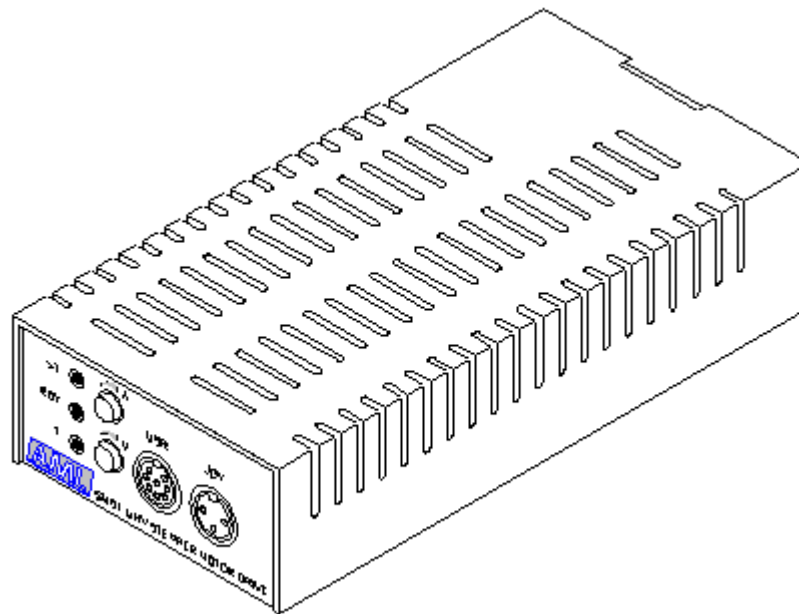

SMD1 is a self-contained, mains-powered drive for UHV stepping motors up to B23.1. It is intended for low-cost applications in stand-alone or externally-indexed modes and also for multi-axis drives when controlled by a programmable motion controller. It complements the SMD2 and extends:

range of applicability of AML drives at both the high and low-ends. Half-step and wave-drive full step modes are provided. An enhanced version, SMD1M, supports step division. Although it is equipped with thermal management functions required for use with vacuum motors, it is economical when used with conventional motors.

- Steps under control of internal oscillator or inputs from TTL/CMOS logic, PLCs, switches, relays, etc.
- Half-step and full-step (wave) drive modes, see 'operating modes' overleaf.
- Ministep option M ( step division by 4, 8, 16 and 32 ) for smooth low-speed rotation.
- Phase currents settable between 0.25 and 1A. Suits AML motors B14.1, B17.1 and B2 and many other 2-phase bipolar hybrid stepper motors.
- Automatic, elective power-reduction reduces outgassing but increases detent torque when stationary.
- Motor over-temperature protection. Panel and signal indication of over-temperature condition.
- SMDJ Joystick optional. The delayed acceleration enables reliable single-stepping by joystick.
- Signal inputs and outputs electrically protected. Drive output is protected against shorts across and between phases and from phase to ground.
- Simple, all-pluggable connections with AML MLF12 leads and accessories.
- SMD1RM, 19" x 2U (88mm, 3½") high rack mount for 4 x SMD1 with integral power distribution and fan cooling is available.

## SPECIFICATIONS:

### OPERATING MODES

Stand-alone. Rotation is under control of the internal oscillator which may be gated by external means. The rotation speed and acceleration are controlled by preset potentiometers to suit the characteristics. Rotation can be initiated and direction controlled by contact closures or logic signals. Alternatively (or additionally) an AML joystick, model SMDJ may be used. Single step substeps may be controlled by momentary contact or joystick command. For limited-motion applications limit-switch inputs are available. Half, full and ministep drive modes are link-selected. Reversals of motion are ignored while the motor is running.

Externally-Indexed or driven by a Motion Controller. Motion is controlled by step and direction. A step or substep is taken for every positive transition of the 'Step' input. Half, full and ministep modes are link-selected.

Size/weight	235 x 99 x 45 mm. 1.4kg.
Supply	230V RMS or 100-110V RMS (option L), nominal, at 50 to 60Hz. < 50VA under conditions
Environment	In operation 30°C max. RH 95% max, non-condensing. IEC 664 Pollution deg Installation cat. II.
Mounting.	Mount horizontally. Cooling is principally by natural convection. 10mm space must be allowed on all faces. Forced-air cooling may be required other arrangements.
	0.25, 0.5, 0.75 or 1A nominal (wave drive). Half-step and mini-step currents as

Phase current	scaled to maintain the same power dissipation. The 'hold' link reduces the phase current by 50% after milliseconds.
Speed	The internal oscillator has a range of <200Hz to >4kHz. 5kHz is the recommended maximum for external drive via the 'step' input. Step division divides the rotation speed by the step d
Acceleration	When the internal oscillator is used the first step is followed by a short delay at acceleration to the preset speed in ½ to 2½ seconds, according to the control potentiometer position
Inputs	74HC, 5V, with 47kR pullup: SI (Step in), NCW (Direction), NGO (oscillator gate SI lockout), NCL (clockwise limit), NCCL (counter-clockwise limit). K thermocouple
Outputs	Motor phases, 70V, <1A, bipolar, 22kHz chop frequency. 74HC, 5V, with 47kR pullup and 470R in series: NOTMP (over-temperature >175°C), SO ( Step out = SI or oscillator when NGO low), Step zero (phase A only energised), RDY (ready = drive and temperature ok).

### ORDERING INFORMATION:

SMD1	UHV Stepper Motor Drive
SMD1M	UHV Stepper Motor Drive with ministep option Add suffix H for 230 volt supply Add suffix L for 100/110 volt supply
SMDJ	
SMDMCC	Joystick for SMD1/SMD2 Motor and thermocouple connectors
SMD1RM	Rackmount for 1 to 4 SMD1 with fans and power distribution

### DUAL UHV STEPPER MOTOR DRIVE MODEL SMD2

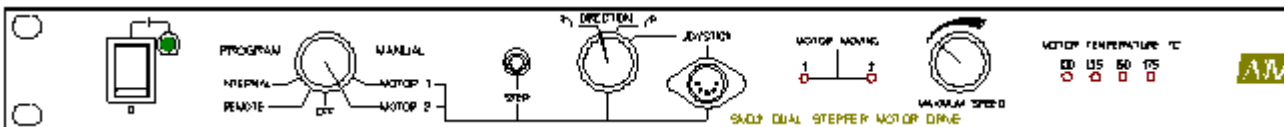

AML's SMD2 Vacuum-Compatible Stepper Motor Drive is designed to match AML motors. Two motors may be driven sequentially either under host computer control, by an internally stored program, from the front panel switches or a hand-held joystick. This drive is also economical for use with compatible air-side motors.

- 1U high full-width, steel-cased instrument for easy rack-mounting.
- Drives 2 UHV stepper motors sequentially.
- Automatic transition between drive modes (step /8, /4, half and full) at user-selected speed.

control resonances.

- Phase currents can be set from 0.1 to 1A in increments of 0.1A.
- Advanced low-power drive techniques for minimum motor temperature rise and outgass and maximum operating time.
- Holding torque can be controlled independently of dynamic torque under program control reduce power.
- Thermocouple amplifiers (type K) for motor temperature indication, protection and control motor bakeout.
- RS232C interface for host computer control. Drive programs can be developed and run on the computer console (Remote Program Control) or downloaded for stand-alone operation (Internal Program Control).
- Motors may be operated manually with the front panel 'STEP' and 'DIRECTION' switches with the joystick. Single-step or multiple-step operation with smooth acceleration to the selected speed.
- 3 user inputs for interaction with program execution, in addition to two "End of travel" inputs each motor.
- 3 user outputs for switching under program control.
- Simple control language has many powerful commands which allow control of all aspects of motion or position. Conditional operation, loops and jumps are possible. All commands consist of single characters, followed by numbers, where appropriate.
- Program development is simplified by improved development software with on-line help and debugging facilities.
- Displays temperature of the motor being driven or baked.
- Supplied with all connectors, mains lead, fuses, joystick, comprehensive manual, interface cable and software for program development on any IBM-compatible PC.
- Simplified connection with MLF12 bakeable lead, feedthrough and connection kit. ( Not included. )
- Economical with standard stepper motors e.g. with motorised motion feedthroughs.
- Operates on any supply from 100 to 240V, 50/60 Hz without adjustment.

This document and the designs depicted are the copyright of Arun Microelectronics Ltd  
Specifications are subject to change, confirm before ordering. E & OE.

contact:

Dipl-Phys. Markus Mayer  
tectra GmbH  
Reuterweg 65  
D-60323 Frankfurt  
phone: Germany (0) 69 - 72 00 40,  
fax: Germany (0) 69 - 72 04 00  
email: [info@tectra.de](mailto:info@tectra.de)  
home: [www.tectra.de](http://www.tectra.de)



**ARUN MICROELECTRONICS Ltd.**

**UHV Compatible Stepper Motors**

**USER INSTRUCTIONS Issue 1.05**

### **SUMMARY AND WARNINGS**

The screws on size 14 and 17 motors are fitted with metered torque. Do not disturb.

Do not drop, demagnetise, disassemble, modify, touch or overheat the motor or allow particles to enter the bearings or pumping ports.

The published performance was obtained using an SMD2 drive operating with standard settings for step division. SMD2 is a bipolar, switch-mode, current-regulating drive, optimised for use with vacuum stepper motors. Different drives will produce different speed/torque curves. Drives capable of producing a total phase current of more than 1A RSS (root sum of squares) may damage the insulation, even if the current is claimed to be adjustable.

Identify the two power windings with a resistance meter. Reverse the connection of either winding to reverse rotation. The thermocouple alumel<sup>®</sup> wire (negative) is magnetic. A small magnet is provided for identification. Wires are terminated in 1.5mm crimp terminals for simple insertion in MLF18 VCF connectors.

Design mechanisms with balanced rotating loads and/or friction to maintain position with zero (or reduced) phase current for minimum outgassing. Use ministep only to smooth transitions: increase resolution by reduction gearing.

Ensure ice cannot form in the motor if testing at low temperature in air. Avoid thermal shocks e.g. plunging in liquid nitrogen.

Motors are supplied pre-baked at HV. They will adsorb water in storage and handling. A 24-hour self-bake by SMD2, with an adequate pump, will achieve UHV-compatibility.

### **HANDLING and INSTALLATION.**

Avoid touching the motor and leads with bare hands. Use clean nylon, cotton or plastic gloves only. On the smaller motors use the extended screws for mounting but do not attempt to remove them: hold the screws stationary with a screwdriver while tightening fixing nuts. Take normal vacuum precautions, avoid creating trapped volumes when mounting the motor and obstruct as few as possible of the pumping holes in the end faces. The location spigot projecting from the face of the motor is accurately concentric with the shaft and intended for precise location in a recess.

### **LOAD CONNECTION**

The preferred method of coupling a load to the shaft is by a set-screw or collet fixing. AML do not recommend users to modify shafts. If it is necessary to file a flat or to drill and pin the shaft, ensure that the motor is protected against ingress of swarf, cutting lubricants and other debris. This can be done by wrapping the complete motor and lead assembly except for the shaft in aluminium foil. Then enclose the motor in a polythene bag, sealing the opening around the shaft with self-adhesive tape. Avoid sealing the tape to the shaft; seal it to the bag or itself. After modifying the shaft clean it with isopropyl alcohol and remove the plastic and foil coverings, taking precautions not to contaminate the motor.

## DRIVE REQUIREMENTS.

These motors are specifically designed for use in conjunction with the AML SMD2 current-regulated switch-mode drive. AML do not recommend the use of alternative drives. If another drive is used it must be a bipolar 2-phase drive and capable of providing a selection of well-regulated currents of less than or equal to 1 Amp per phase. If the drive can provide simultaneous currents to both phases (for step division) then the root of the sum of the squares of the phase currents must never exceed 1 Amp. Some drives having a large current capability have very poor tolerances on low current settings.

The source voltage of alternative drives should be greater than 45V for size 14 and size 17 motors and greater than 65V for larger motors. Lower voltages will result in loss of torque at higher stepping rates. Voltages over 100V are not suitable for vacuum use. Switching frequencies should not exceed 22kHz and peak-to-peak switching ripple on the phase current should not exceed 15%.

The drive current should be reduced or removed when the motor is stopped. For this reason attempts to improve angular resolution by step division are not recommended,

Refer to the current motor data sheet for electrical, mechanical and thermal characteristics.

## OVER-TEMPERATURE PROTECTION.

All AML motors are provided with a K-type Thermocouple (Chromel/Alumel) embedded between adjacent windings, which must be used for over-temperature protection. The drive current must be removed when the indicated temperature of the windings reaches 175°C. The SMD2 drive provides this function. Simple on/off temperature controllers may be used but ensure that the adverse electrical noise environment within the motor under drive does not affect the temperature measurement.

## FEEDTHROUGH REQUIREMENTS.

Each motor requires six vacuum feedthrough pins. It is not necessary to use a thermocouple vacuum feedthrough, as the error introduced by incompatible feedthrough material is usually less than 5 degrees.

AML feedthrough MLF18F is recommended, since it mates directly with the 1.5mm crimp socket terminals fitted to motor leads and simplifies installation.

MLF18F has 18 1.5 mm gold-plated feedthrough pins and is suitable for one to three motors. An internal bakeable connector, MLF18VCF, is available into which the crimp terminals on the motor leads are inserted. This significantly reduces the risk of short-circuits and makes the installation more convenient. Motors may be ordered with connectors fitted.

AML supply an 18-way bakeable, screened external lead, MLF18L for direct connection to SMD2 drives. The use of this lead ensures compliance with the EU EMC Directive 89/336/EEC. Air-side connectors, MLF18AC are available for users wishing to make their own cables.

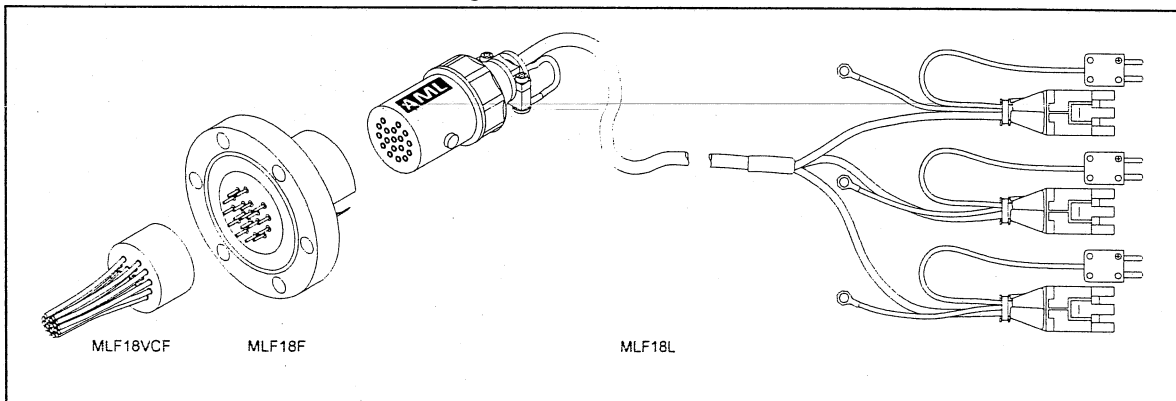

## IDENTIFYING AND CONNECTING THE LEADS.

It is very easy to identify and connect the leads. An ohmmeter with resolution down to about 1 ohm is required to identify the two phase windings: most inexpensive multimeters are suitable.

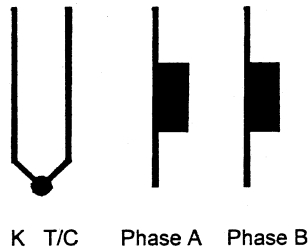

The leadout wires are self-coloured polyimide film-wrapped silver-plated OFHC copper wires and each is fitted with a 1.5mm crimp socket terminal.

The phase leadout wires are much thicker than the thermocouple leadouts. Radiation-hard motors have multi-strand leads. Identify the two motor phases by their resistance, which will be in the range of 3 to 15 ohms, depending on the motor type. There is no electrical connection between the two phases or to the thermocouple or the case of the motor. Most of the resistance is in the windings of the motor and is virtually unaffected by shortening of the leads. Connect each phase to the appropriate drive terminals. The resistance of the wires from the feedthrough to the drive must be less than a few ohms.

The thermocouple wires are much thinner than the phase leads. The thermocouple is insulated from the rest of the motor. The resistance of the thermocouple is 50 to 60 ohms, as supplied, and is proportional to the length, if shortened. The Alumel wire may be identified with the magnet supplied, since it is weakly magnetic. At the controller the Alumel lead should be connected to the terminal marked Alumel, N, -, or coloured blue, and the Chromel lead should be connected to the terminal marked Chromel, P, + or coloured brown.

The temperature measurement is not required to be very precise, so it is not necessary to use thermocouple-compatible feedthroughs or extension wires. If compatible materials are used then they must be connected the correct way round.

## CONNECTION TO MLF18VCF OR MLF18F

If you are connecting crimp terminals directly to the feedthrough (i.e. not using MLF18VCF) do not forget to thread the wires through the copper gasket before connecting to the feedthrough! To avoid short-circuits insulate the crimp terminals with PTFE sleeving.

If you are using MLF18VCF it will be useful to have a socket extractor tool. RS Components stock number 466-876 is suitable and inexpensive.

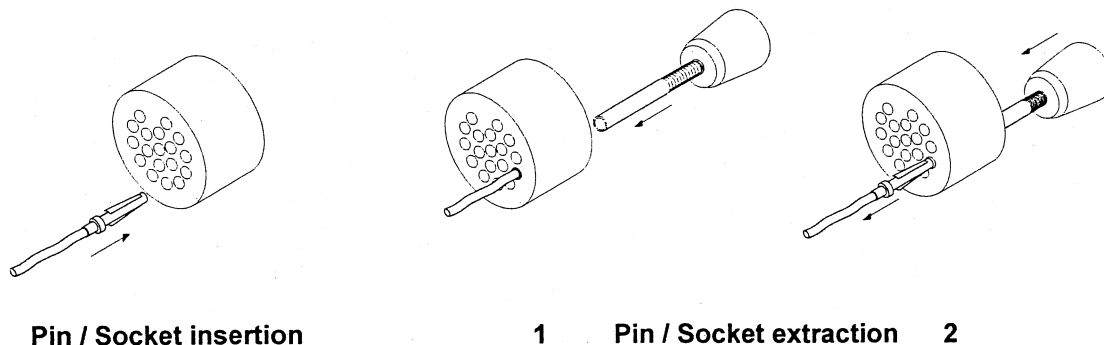

Make connections according to the following conventions. This will ensure compatibility with MLF18L leads. The diagram shows the rear of the connector or the vacuum side of the feedthrough.

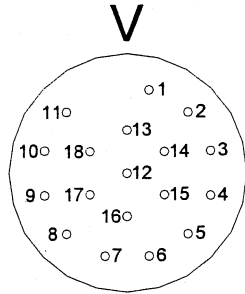

	Motor 1	Motor 2	Motor 3
Phase A+	1	7	13
Phase A-	2	8	14
Phase B+	3	9	15
Phase B-	4	10	16
Thermocouple +	5	11	17
Thermocouple -	6	12	18

**PREPARATION OF MOTOR LEADOUT WIRES FOR USE WITH OTHER FEEDTHROUGHS.**

It will be necessary to cut off the crimp terminals fitted to the leads and re-strip them. Standard motors are fitted with Polyimide film-wrapped leads: radiation- hard motors are fitted with Polyimide lacquer-coated leads.

Polyimide is strong, flexible and abrasion-resistant and therefore difficult to strip. The simplest method of stripping polyimide film is to cut a ring with a sharp knife and withdraw the cylinder of insulation over the end of the wire. Be careful not to mark the conductor surface with the knife. Strip lacquer-coated radiation-hard leads by scraping with a sharp knife. Either type of lead may be stripped with a suitable high-speed rotary stripper. Do not use a thermal stripper.

**Do not forget to thread the wires through a copper gasket before connecting to the feedthrough!**

**REVERSAL OF ROTATION.**

Since the phases are not identified there is a 50% probability that the direction of rotation will be reversed from the desired or conventional sense. To reverse the direction exchange the connections to **one** of the phases.

**Check that the drive, wiring and motor combination work properly before closing the vacuum system!**

**TROUBLESHOOTING.**

If the motor rotates at the wrong speed, frequently changes direction or has low torque this is probably due to one of the phase connections being open-circuit.

If the SMD2 indicates that the motor temperature exceeds 175° when the motor is not hot then a connection to the thermocouple is open-circuit.

Refer to the SMD2 manual for other problems.

## **GENERAL OPERATION CONSIDERATIONS FOR UHV-COMPATIBLE MOTORS.**

It is recommended that motors and mechanisms are operated in air during early commissioning. This has the advantage that more cooling is available and that the operator can see and hear that the motor is stepping.

### **Temperature rise and run times.**

The maximum recommended running temperature of AML motors is 175° Celsius, as measured by the embedded type K thermocouple. In general, the risk of exceeding this temperature with size 14 and 17 motors in typical vacuum installations with SMD2 is very small. Size 23 motors will reach this limit in about 10 minutes under full drive. Cooling rates near maximum operating temperatures are much greater than heating rates so high duty-cycles can be achieved, even with the larger motors, provided gas loads remain acceptable.

The motor should be run at the minimum phase current consistent with the requirements of the load. This will reduce the maximum temperature of the motor and outgassing from the motor. Resistive heating losses in the winding resistance,  $R$ , are given by  $I^2R$ . The winding resistance is approximately proportional to absolute temperature so even small reductions in phase current,  $I$ , produce worthwhile reductions in temperature rise and outgassing. For phase currents down to about 50% of maximum the output torque is reduced roughly in proportion to phase current.

The minimum practical phase current is determined by the load friction and inertia, and the required acceleration and maximum speed. It is best found by experiment. A reasonable margin of safety should be allowed for any expected increase in load friction, which might occur after bakeout.

Vacuum stepper motors achieve maximum efficiency at full-step rates between 500 and 2kHz.

The SMD2 allows the reduction of the phase current dynamically during each step at low step rates, with separate control of initial and final currents and transition times. Use of this technique can dramatically reduce the power dissipated in some applications.

The provision of any heatsinking means will improve the performance.

Irreversible deterioration of the winding insulation will occur at 230°C and the motor will subsequently produce large amounts of gas, even at lower temperatures.

### **Outgassing and Bakeout.**

A newly-installed motor will outgas in vacuum, mainly due to water-vapour retention in the polyimide. As this material is micro-porous the water is released rapidly and the rate will subside after a few hours. The rate may be accelerated by running the motor to self-heat it.

Baking at up to 200° C is required for operation at UHV. Motors are typically operated at some distance from the chamber walls where the bakeout temperature is most often controlled. The motors will not reach a high enough temperature in such cases, and it may be increased by using the windings as heating elements. The SMD2 includes a bake program, which automatically controls the motor temperature at 175°C by applying phase current. Maintain the motor temperature above that of the rest of the system during cooling, as this will prevent condensation on the motor. Where internal infra-red heaters are used for bakeout it is advisable to shield the motor from direct radiation and to achieve controlled temperature during bakeout solely by self-heating.

The outgassing rate for well-baked motors installed on a typical mechanism and run below 120°C winding temperature is in the order of  $10^{-8}$  millibar litres  $\text{sec}^{-1}$ . This represents high duty-cycle operation at rated phase current for size 14 and 17 motors. The gas species are  $\text{H}_2$  (90%) and CO (10%) and originate mainly from the windings and laminations. As a rule of thumb, an additional 100 litres per

second of pumping capacity per motor will be required for UHV. This gas load is insignificant at HV and higher pressures.

### **Rotation Mechanisms - Holding Torque.**

Design rotation mechanisms with balanced loads to reduce or eliminate the necessity for holding torque. If the torque imposed on the motor by any imbalance of the load is less than the detent torque then the motor will hold position without power. The gearing required to achieve the desired angular resolution or to match the load inertia will increase the effect of detent torque and also add friction.

### **Translation Mechanisms - Shaft end-float.**

The motor shaft has a compression spring, which pushes the shaft toward the mounting-face of the motor. The amount of end-float is nominally 100 $\mu$ m. The spring is fully exercised with an axial force of 3kg toward the rear of the motor. In linear mechanisms where the motor is directly-coupled to a leadscrew use gravity and/or apply an opposite axial pre-load to avoid adding end-float to backlash.

### **Resonances.**

Stepper motors are classic second-order systems and have one or more natural resonant frequencies. Operation at step rates around these frequencies will excite the resonances, resulting in very low output torques and erratic stepping. The resonant frequency is modified by the friction and inertia of the load, the temperature of the motor and by the characteristics of the drive and therefore cannot be stated with any precision. Fortunately, coupling a load normally reduces the resonant frequencies, which for unloaded AML motors occur below 300Hz. The drive circuits of the SMD2 are optimised to produce heavy damping of mechanical oscillations in the motors.

The simplest method of controlling resonances is to avoid operation of the motor close to the resonant frequencies. It is almost always possible to start a motor at rates in excess of 400Hz if the load inertia is matched as described in the next section. Resonances are not usually a problem when the motor speed is accelerating or retarding through the resonance frequency region.

If it is necessary to operate at slower speeds than this the step division feature of the SMD2 (ministep) helps by effectively increasing the stepping rate by the step division factor and reducing the amplitude of the step transients which excite the resonances. In particularly difficult cases modifying the step frequencies at which transitions of the step divisions (ministep modes) occur can be useful.

### **Load inertia and reduction gearing.**

The load inertia coupled to the motor shaft should ideally be comparable to the rotor inertia of the motor where accurate position control is required. The load inertia can be very much larger for speed control applications where some slip of absolute position is unimportant. Where reduction gearing is used for load-matching the spur gear meshing with the motor pinion will normally dominate the load inertia and it is important to keep its diameter small. Loosely-coupled loads may give rise to additional resonances at higher frequencies: these can usually be damped by substituting either anti-backlash or helical gears in the gear train or arranging additional friction in the train.

### **Magnetic fields near the motor.**

It is recommended that motors are not operated in fields of greater than 50 millitesla (500 gauss), as this will affect the performance while the field is present. Fields of significantly greater than this may cause partial demagnetisation of the rotor, permanently affecting the performance.

The leakage field of a motor is less than 100 microtesla (1 gauss) at 1 cm from the cylindrical surface of the motor and in an axial direction. It is due to the permanent magnet in the rotor and is present when the motor is stationary and unpowered. Under drive an alternating component is added at the fundamental and harmonics of step frequency, up to a few kHz. This field is easy to screen at the sides and non-shaft end of the motor, but more difficult at the shaft end because of the projection of the shaft. Early consideration of the interaction of stray fields on nearby equipment is recommended.

#### **REPAIR AND REFURBISHMENT.**

Any product returned to AML or its agents for repair must be accompanied by a signed statement by the user stating clearly the nature of any hazardous material used in its operating environment and decontamination procedures performed. Forms for this purpose are available from AML agents and distributors. AML will not accept the return of motors and other items, which have been mounted in the growth chambers of MBE systems.

**Document No. J:\MAN\CMOT  
Stock No. KCMOTMANUSR**