

LASER INTERFEROMETER GRAVITATIONAL WAVE OBSERVATORY

-LIGO-

CALIFORNIA INSTITUTE OF TECHNOLOGY

MASSACHUSETTS INSTITUTE OF TECHNOLOGY

Document Type	DCC Number	February 3, 2006
	LIGO T060032-00-C	
Lasti Suspension Digital Controls Design		
R. Bork		

Distribution of this draft:
This is an internal working note of the LIGO Laboratory

California Institute of Technology
LIGO Project – MS 18-33
Pasadena, CA 91125
Phone (626) 395-2129
Fax (626) 304-9834
E-mail: info@ligo.caltech.edu

Massachusetts Institute of Technology
LIGO Project – MS 20B-145
Cambridge, MA 01239
Phone (617) 253-4824
Fax (617) 253-7014
E-mail: info@ligo.mit.edu

www: <http://www.ligo.caltech.edu/>

1 Scope

The scope of this document is the digital controls design for the CDS implementation for the quad suspension tests, and later interferometer testing, at Lasti. This includes the Analog to Digital and Digital to Analog conversion of sensor and control signals and computer processing and algorithms. Excluded from the scope of this document is the electronics and wiring necessary to interface to the system sensors and actuators (covered by separate documentation).

2 Purpose

The purpose of this document is to describe the digital hardware and software required to operate the suspension systems to be installed at Lasti. This includes the interface definitions between the digital controls and the analog field hardware and the digital controls to the remaining Lasti CDS infrastructure.

3 References

1) LIGO T060031-00-C LASTI Digital Control and Data System Design

4 Overview

Over the course of the next year, various systems will be installed at Lasti for advanced interferometer tests and experimentation. As a part of this effort, a new Control and Data System (CDS) will be provided. An overview of the CDS is given in the reference document LIGO T060031-00-C.

The Lasti suspension controls described in this document are to evolve in two stages. In its initial incarnation, this CDS suspension control subsystem will control and monitor all stages of the quad suspension during its initial test phases. In a later phase, this unit will provide controls for the two upper quad suspension stages, the upper triple (4) suspension stages and SOS 1. The control of the lower stages of the quad and triples will move to the IFO controller in phase 2, along with control of SOS2 and SOS3. The reason for this later change is that the upper stages of the multi-stage optics systems are independent and do not require LSC or ASC inputs, whereas the lower stages do. The advantages hoped to be realized from this scheme are:

- Reduction in realtime network traffic ie no communication of LSC and ASC data across the MyriNet. Note, however, that communications across the MyriNet are possible if and where required.
- No control latency between suspension control outputs and LSC and ASC calculations. In the LIGO system of separate suspension and ISC computers, there is an inherent one cycle delay in the application of ISC signals to suspensions. In this configuration, the delay would be removed.

The following subsections describe the signal connections and software for the two installation phases.

5 Suspension Controls – Phase I

Phase I installation is to begin in April 2006. For this phase, the suspension controller will provide for all CDS functions required for quad suspension testing.

5.1 Hardware

This initial installation of suspension digital controls will include the following hardware. Further descriptions of this hardware may be found in Ref. 1.

- One dual AMD64 computer
- One PCI-X expander chassis
- One ADC module
- Two DAC modules

- One MyriNet Network Interface Card (NIC)

A sketch of the suspension digital control components for phase I and their interconnection are shown in the following figure.

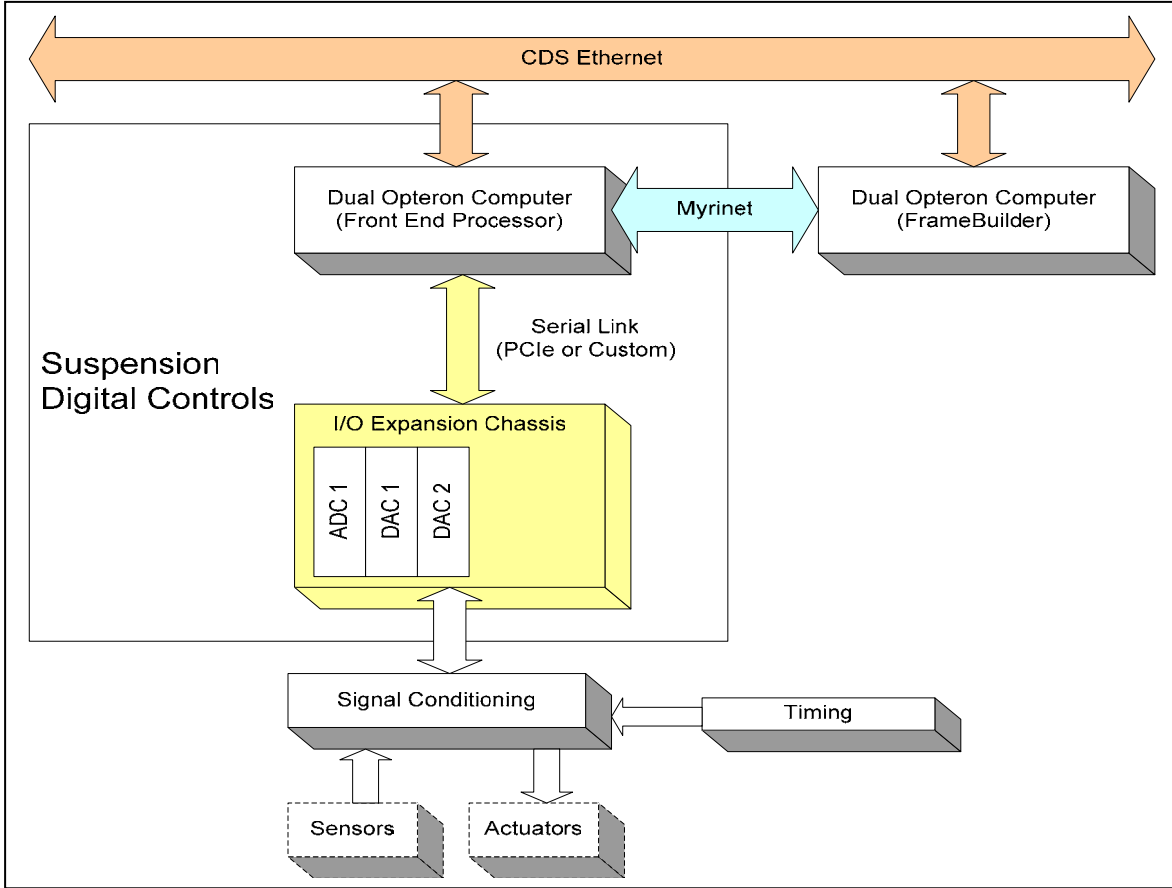

5.1.1 Analog Signal Connections

Analog signals will be connected to the digital I/O modules via cabling from the analog signal conditioning units. The signal connections to the ADC and DAC modules are given in the following tables. Along with the signals listed, timing clocks from the Lasti timing system will also be provided to all ADC/DAC modules via the analog conditioning units.

ADC MODULE 1 – Quad Sensor Signals			
Ch.	Signal	Ch.	Signal
00	M0 Face 1	16	NC
01	M0 Face 2	17	NC
02	M0 Face 3	18	L2 UL Sensor
03	M0 Left	19	L2 LL Sensor
04	M0 Right	20	L2 UR Sensor
05	M0 Side	21	L2 LR Sensor
06	R0 Face 1	22	NC
07	R0 Face 2	23	NC

08	R0 Face 3	24	NC
09	R0 Left	25	NC
10	R0 Right	26	NC
11	R0 Side	27	NC
12	L1 UL Sensor	28	NC
13	L1 LL Sensor	29	NC
14	L1 UR Sensor	30	NC
15	L1 LR Sensor	31	One PPS Signal

DAC MODULE 1			
Ch.	Signal	Ch.	Signal
00	M0 Face 1	08	R0 Face 3
01	M0 Face 2	09	R0 Left
02	M0 Face 3	10	R0 Right
03	M0 Left	11	R0 Side
04	M0 Right	12	L1 UL
05	M0 Side	13	L1 LL
06	R0 Face 1	14	L1 UR
07	R0 Face 2	15	L1 LR

DAC MODULE 2			
Ch.	Signal	Ch.	Signal
00	NC	08	ESD Bias
01	NC	09	ESD Quad 1
02	L2 UL	10	ESD Quad 2
03	L2 LL	11	ESD Quad 3
04	L2 UR	12	ESD Quad 4
05	L2 LR	13	NC
06	NC	14	NC
07	NC	15	NC

5.1.2 Digital Signal Connections

Two digital signal paths exist to/from the suspension control computer. All realtime network traffic, including data acquisition, is routed through the CDS Myrinet fabric. The suspension computer will be connected to this network via a pair of multi-mode fiber optic cables.

For transmission of EPICS data and other non-realtime communications, the suspension computer will be connected to the Lasti CDS Ethernet. This is a 100baseT copper wire connection via an RJ45 connector.

5.2 Software

The quad suspension control software consists of five primary blocks, all to run at 16384Hz. There are two blocks for the upper stages (designated M0 and R0), two blocks for the lower stages (designated L1 and L2) and an Electro-Static Drive (ESD) section.

The software for the M0 and R0 stages is identical. A block diagram is shown in the following figure. Each stage has six sensors, which are read in via ADC channels and are input through CDS filter modules (FM). The six filtered sensor signals are applied to six degree of freedom (DOF) filters via an input matrix. The six DOF filter outputs are sent via an output matrix to six output FM. The output filter modules in turn drive six DAC channels.

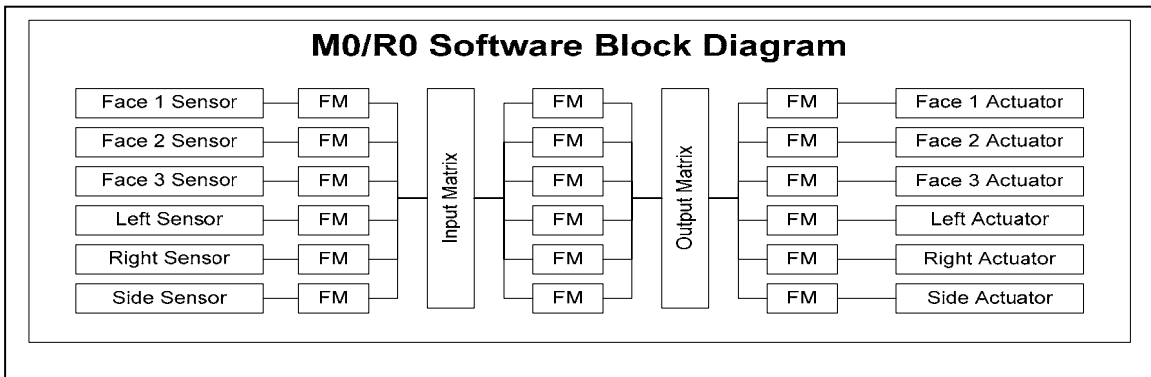

The software for the L1 and L2 stages are identical to each other as well. A block diagram is shown in the following figure and is very similar to present LIGO suspension algorithms. In this initial installation, LSC and ASC connection filter modules are implemented, however, there are no inputs available until the time of the IFO controller.

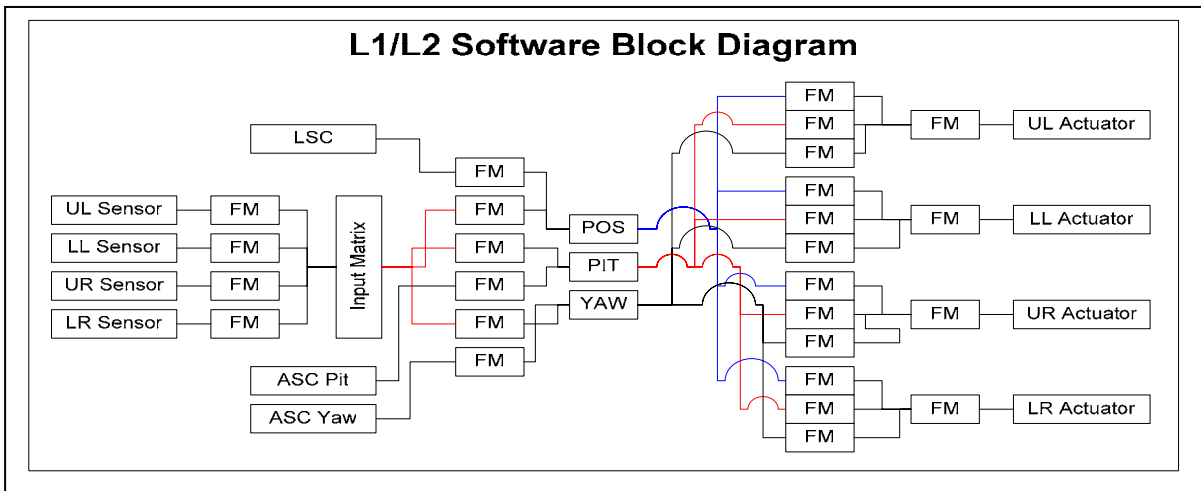

The following block is the ESD control section. Again, no LSC and ASC inputs will be available in phase I. However, if tests requirements dictate, offsets may be set into the FM to 'manually' drive the ESD stage.

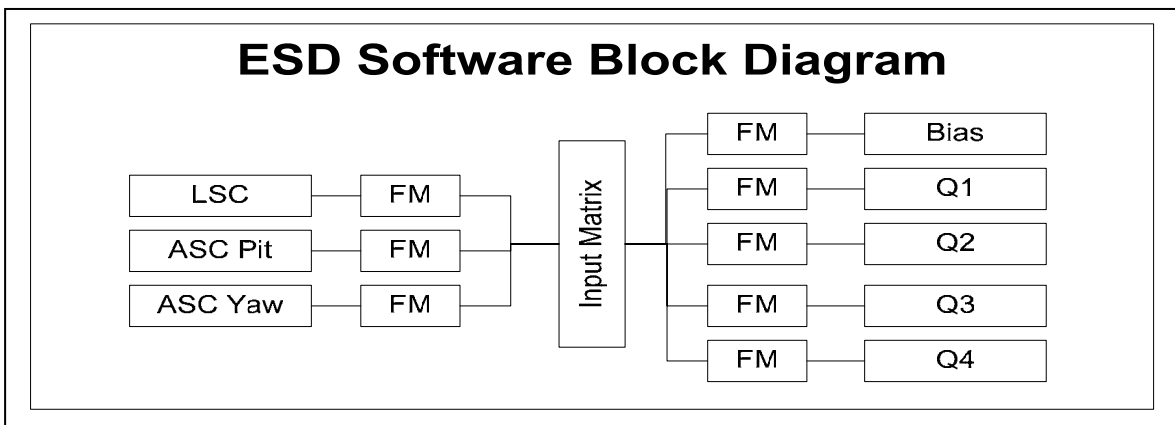

To connect to the FrameBuilder, the software must also provide a unique Data Collection Unit Identification (DCUID) number. The present scheme has DCUID 9 thru 20 reserved for 16KHz systems, and DCUID 21 thru 30 reserved for 2KHz controllers. The suspension controller is to be designated DCUID 9.

6 Suspension Controls – Phase 2

In phase 2, the functions of the L1/L2 and ESD control software (shown above), move to another CDS computer, the IFO controller. The control of the upper stages of the triple suspension and the control of SOS 1 is added.

6.1 Hardware

The added control functions will require the addition of one ADC module and one DAC module, along with a digital I/O module. In all other aspects, the hardware remains the same, as shown below.

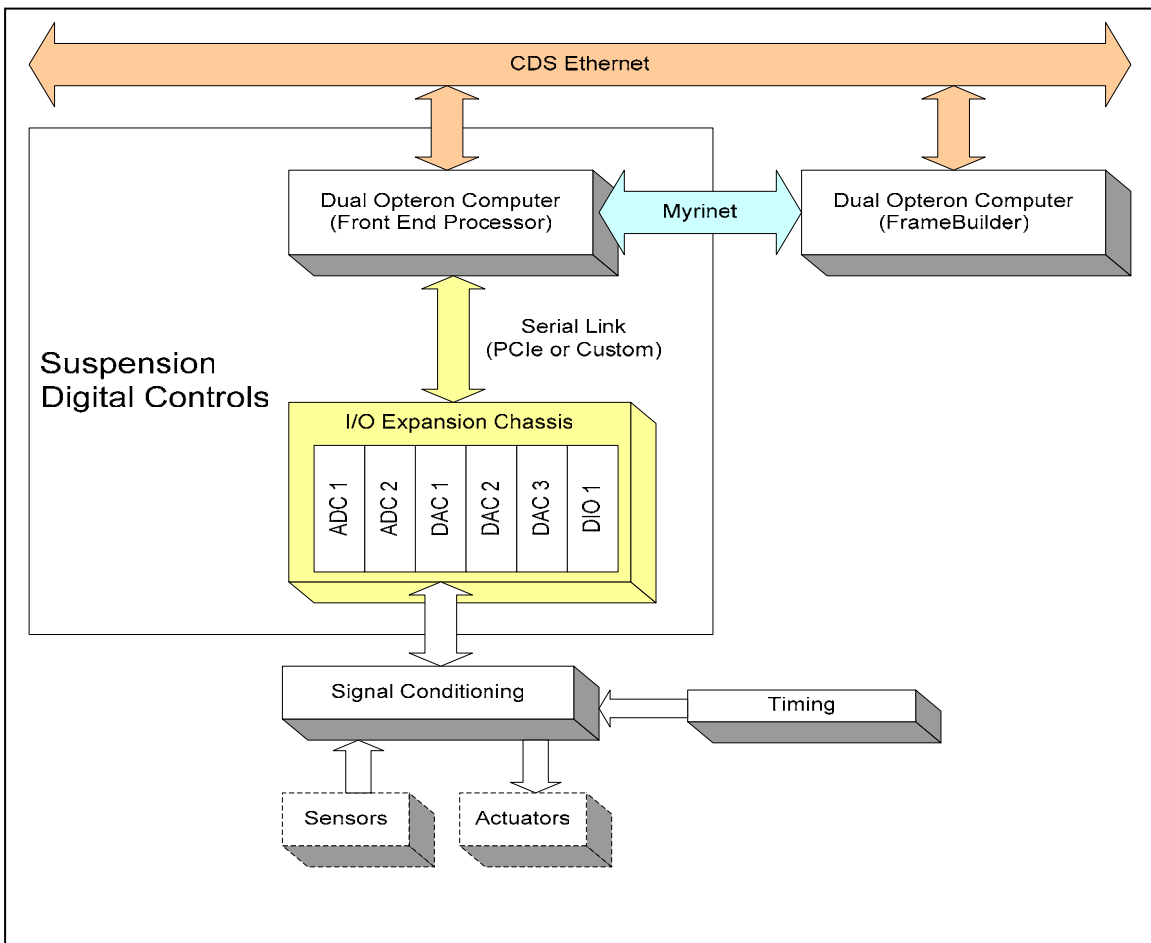

6.1.1 Analog Signal Connections

A preliminary signal list is given in the following tables. Note that this is done for channel counting purposes only with exact connection points TBD.

ADC MODULE 1 – SUS			
Ch.	Signal	Ch.	Signal
00	M0 Face 1	16	MC1 Face 1
01	M0 Face 2	17	MC1 Face 2
02	M0 Face 3	18	MC1 Face 3
03	M0 Left	19	MC1 Left
04	M0 Right	20	MC1 Right
05	M0 Side	21	MC1 Side
06		22	
07		23	
08	R0 Face 1	24	MC2 Face 1
09	R0 Face 2	25	MC2 Face 2
10	R0 Face 3	26	MC2 Face 3
11	R0 Left	27	MC2 Left
12	R0 Right	28	MC2 Right
13	R0 Side	29	MC2 Side
14		30	
15		31	

ADC MODULE 2 – SUS			
Ch.	Signal	Ch.	Signal
00	SOS1 UL	16	MC3 Face 1
01	SOS1 LL	17	MC3 Face 2
02	SOS1 UR	18	MC3 Face 3
03	SOS1 LR	19	MC3 Left
04	SOS1 Side	20	MC3 Right
05		21	MC3 Side
06		22	
07		23	
08		24	TM Face 1
09		25	TM Face 2
10		26	TM Face 3
11		27	TM Left
12		28	TM Right
13		29	TM Side
14		30	
15		31	

DAC MODULE 1			
Ch.	Signal	Ch.	Signal
00	M0 Face 1	08	R0 Face 1
01	M0 Face 2	09	R0 Face 2
02	M0 Face 3	10	R0 Face 3
03	M0 Left	11	R0 Left
04	M0 Right	12	R0 Right
05	M0 Side	13	R0 Side
06		14	
07		15	

DAC MODULE 2			
Ch.	Signal	Ch.	Signal
00	MC1 Face 1	08	MC2 Face 1
01	MC1 Face 2	09	MC2 Face 2
02	MC1 Face 3	10	MC2 Face 3
03	MC1 Left	11	MC2 Left
04	MC1 Right	12	MC2 Right
05	MC1 Side	13	MC2 Side
06	SOS1 UL	14	SOS1 LL
07	SOS1 UR	15	SOS1LR

DAC MODULE 3			
Ch.	Signal	Ch.	Signal
00	MC3 Face 1	08	TM Face 1
01	MC3 Face 2	09	TM Face 2
02	MC3 Face 3	10	TM Face 3
03	MC3 Left	11	TM Left
04	MC3 Right	12	TM Right
05	MC3 Side	13	TM Side
06		14	
07		15	SOS1 Side

6.1.2 Digital Signal Connections

The digital network connections remain the same for Phase 2.

6.2 Software

The software for phase 2 will involve control and monitoring of the upper stages of the quad and triple suspension along with control of SOS1. The quad and triple upper stage software is identical to that shown previously for the quad M0 and R0 stages. In this case, there will be a total of six such software blocks.

The SOS1 controls will be essentially identical to that used in Ligo. A block diagram of that software is shown in the following figure.

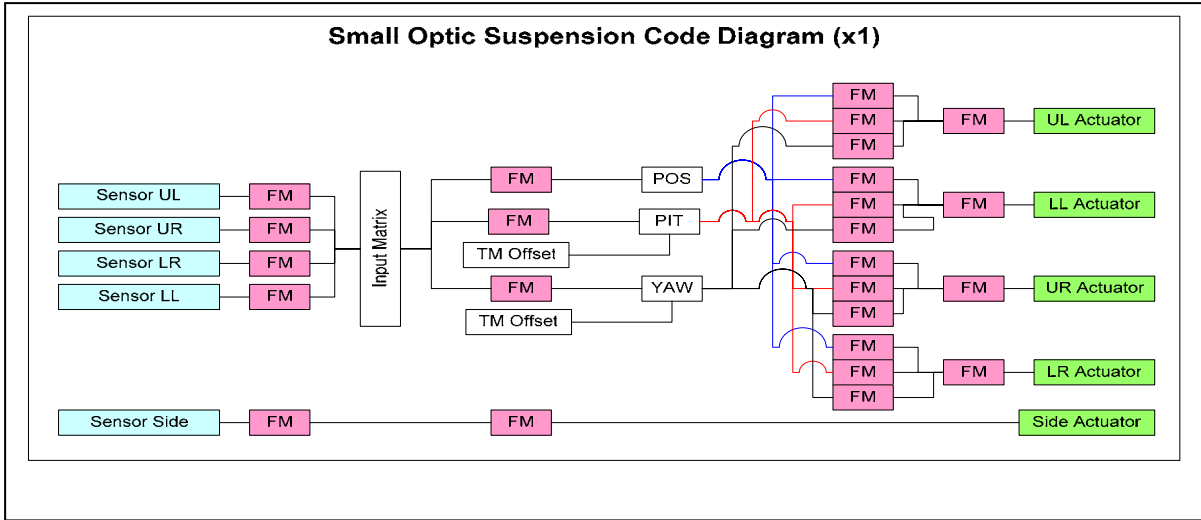

7 Cost Estimate

The following table provides a cost estimate, less tax and shipping charges, if any, for the suspension controls. This represents the total cost for phase 1 and phase 2. Note that this estimate is for the digital controls described in this document only and does not include any analog signal conditioning and cabling required to complete the suspension controls (covered in other documentation).

Lasti Suspension Controller Hardware Cost Estimate			
Item Description	Quantity	Unit Cost	Total Cost
Dual AMD64 Computer	1	\$3500	\$3500
PCI Expander	1	\$3100	\$3100
ADC Module	2	\$4000	\$8000
DAC Module	3	\$3500	\$10500
Digital I/O Module	1	\$175	\$175
Myrinet NIC	1	\$550	\$550
Misc Install Parts	1	\$500	\$500
Total Hardware Costs			\$26,325