

E2E's Physics tools

Ligo doc. no. G020044-00-E

Date: Mar 18, 2002

E2E school, LLO

Biplab Bhawal

LIGO, Caltech

Tools:

- Optics
- Electronics
- Mechanical
- Mathematical functions
- Data generation and output

Optics

- Laser & Field
- Field operations
 - ›› modulator, sideband-gen, sideband-filter, freq-shifter
- Beam operations
 - ›› propagator, shifter, wiggler
- Mirror, lens, telescope
- Summation cavities
 - ›› Fabry-Perot, triangular, recycling cavity,
- Measurements:
 - ›› power-meter, photodetector,

Laser

(The “field-gen” module)

- Laser (a la “field-gen”) generates field at a fixed central frequency
- It could be plane-wave or a Gaussian beam
- If it’s a Gaussian beam, its basis (distance to waist and waist-size) needs to be specified
- amplitude of different spatial modes (in Hermite-Gaussian basis) can be specified

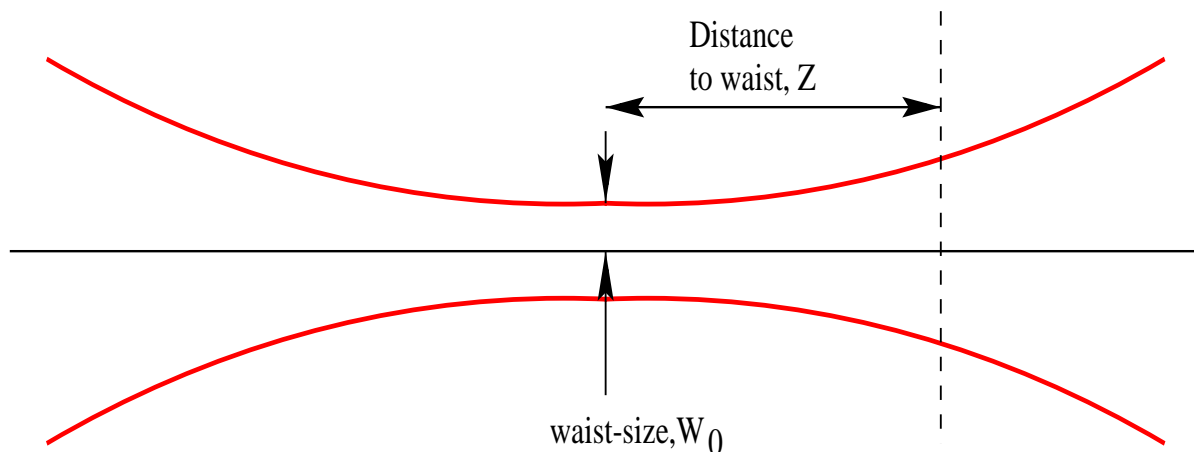

Sideband generator

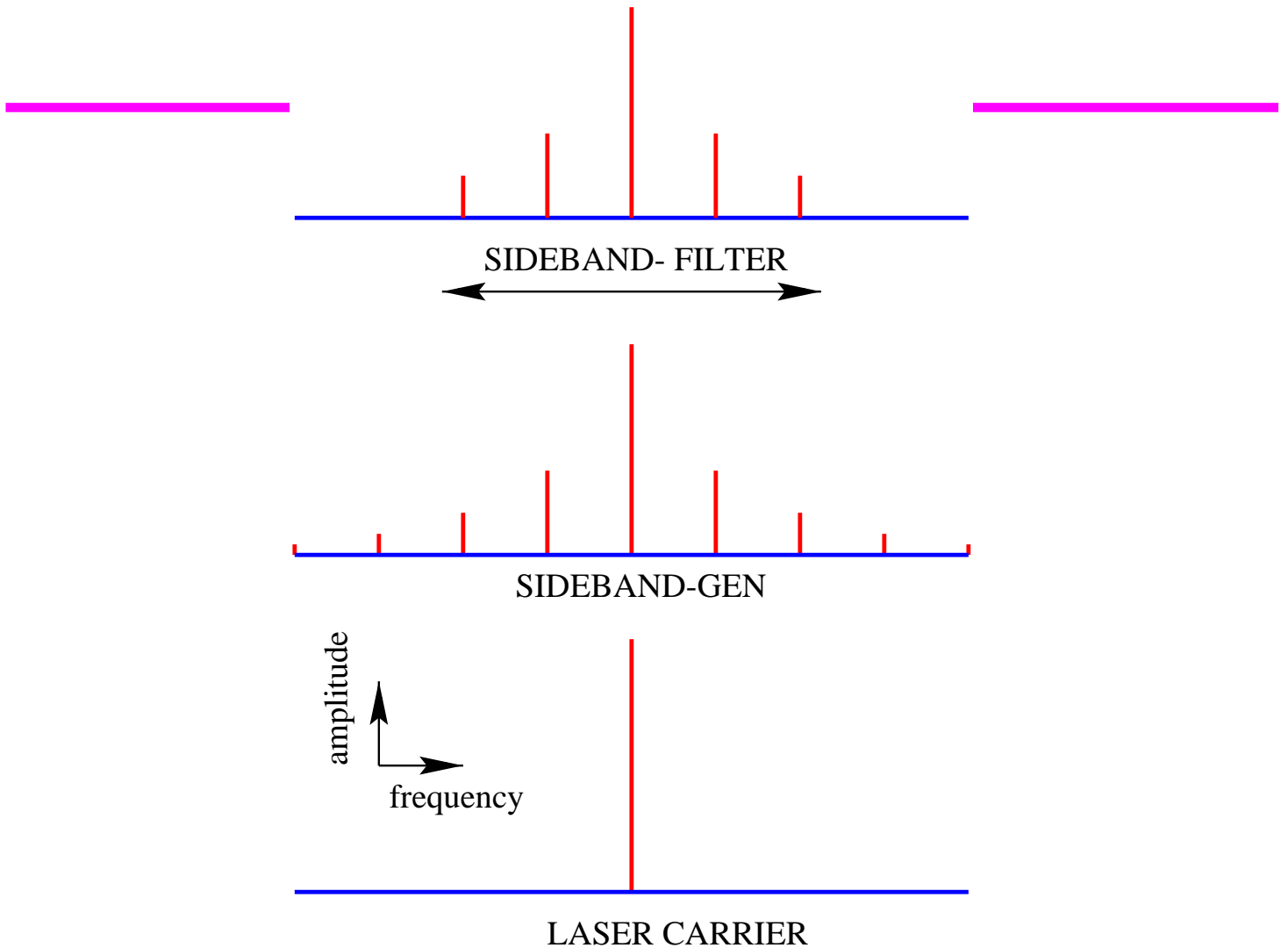

›› “Sideband-gen”:

$$E_{\text{out}} = E_{\text{in}} \cdot \text{Exp}(i\Gamma_{\varphi} \sin(\Omega t)) \cdot \text{Exp}(\Gamma_{\text{amp}} \sin(\Omega t))$$

$$E_{\text{out}} \approx E_{\text{in}} \cdot \sum_{n=-N}^N \left(\sum_{i=-N}^N (-i)^{n-i} \cdot J_i(\Gamma_{\varphi}) \cdot I_{n-i}(\Gamma_{\text{amp}}) \right) \cdot \exp(in\Omega t)$$

Phase and Frequency noise (as input to Laser)

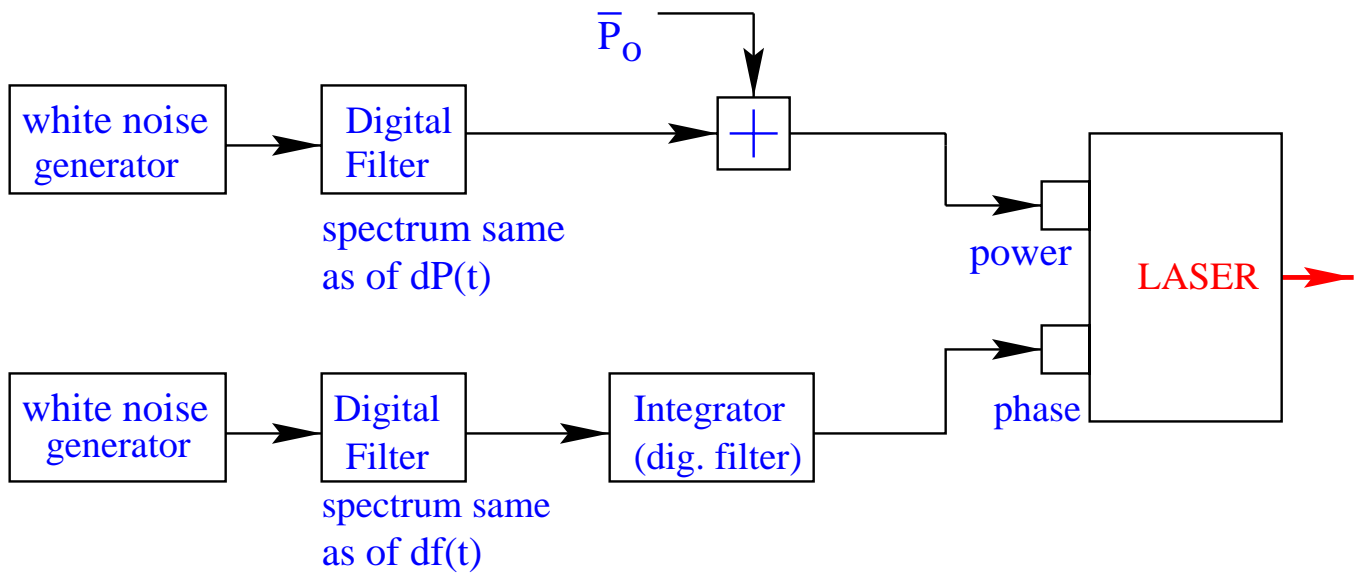

- ›› **Note:** All frequencies of carrier and sidebands are constants during the simulation
- ›› implementation of frequency noise:

$$\phi(t) = \int_0^t \omega(t) dt = \omega_0 \cdot t + \int_0^t \delta\omega(t)$$

- ›› At any other point use “Field-modulator” module
- $$\text{out} = \text{in} * (1 + \text{del_amp}) * \exp(i * \text{phi})$$

Time-domain modal model

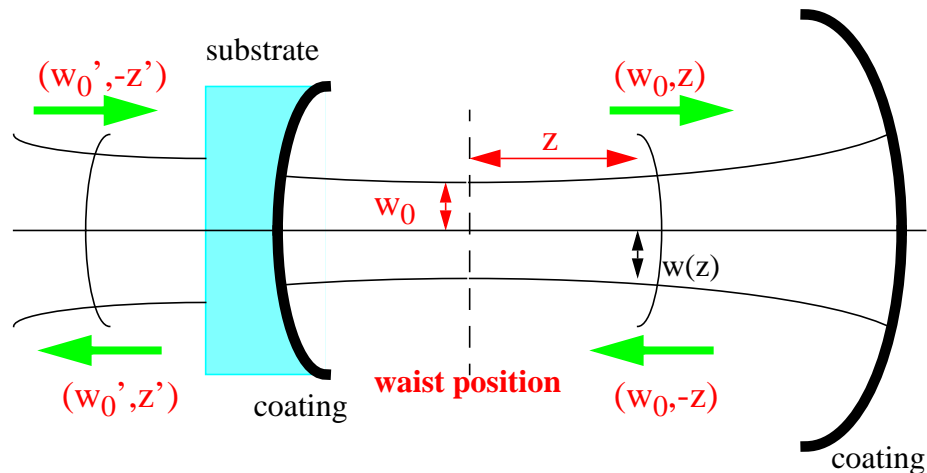

- ›› Field carries two modal info: waist-size, dist-to-waist
- ›› Tilt, shift, curvature mismatch are treated using mode decomposition matrix
- ›› Modal basis changes
 - after passing thru lens/curved mirror
 - on reflection at an angle from a curved mirror

contents of 'Field'

- ›› In E2E modes upto 4th order (15 modes) can be considered

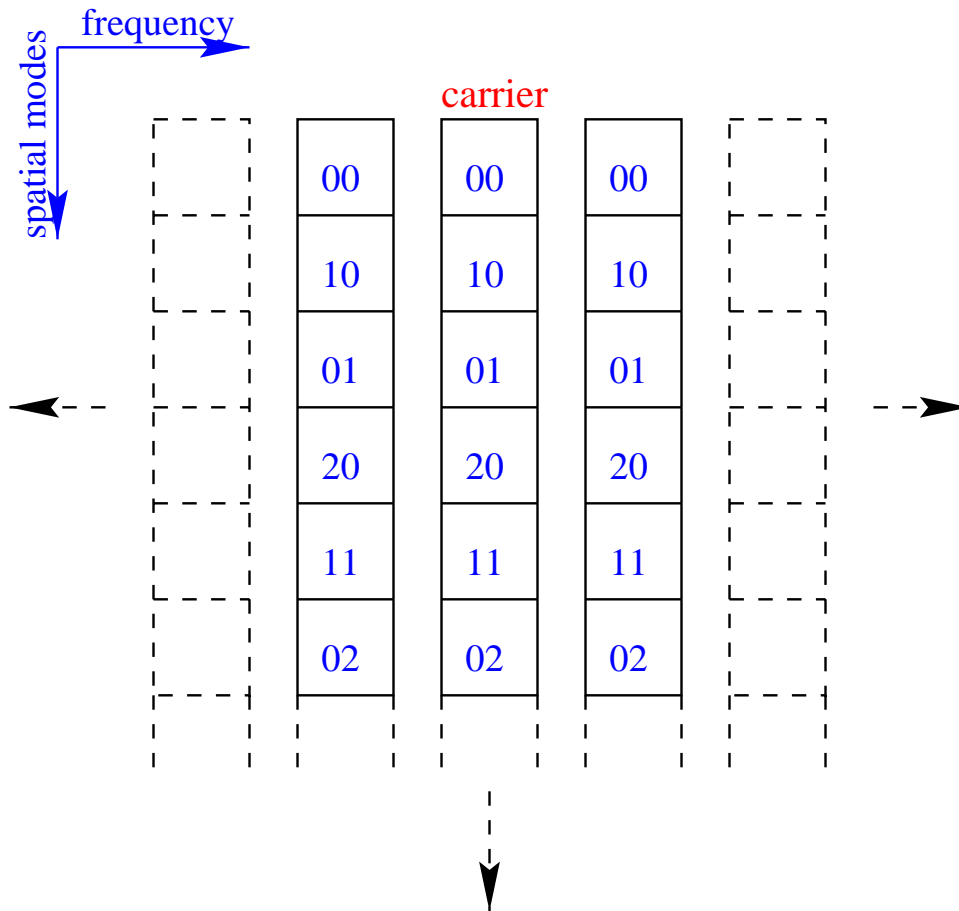

- ›› a “power-meter” module can measure power
 - for any mode of any frequency
 - For one freq: total power of all modes or modes of a certain order

Photodetector

- Pd-demod:

- >> photodetector+demodulation+low_pass_filter

- >> shape

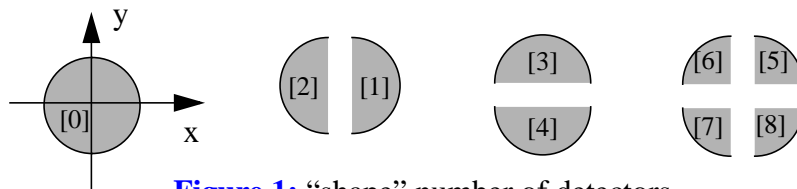

Figure 1: “shape” number of detectors

- >> “detmap”

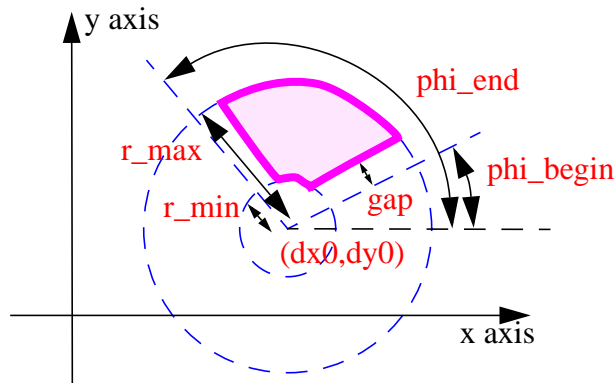

Figure 2: Specification of a detector

- >> ready-made boxes

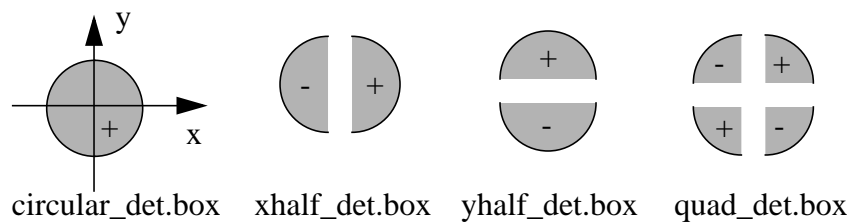

Figure 3: detector boxes

misalignment effects

(in Hermite-Gaussian basis)

- Initial beam : k - mode no. ; w - waist

$$AU_0$$

- 'Beam-wiggler': deviation (p) of beam by an angle

$$A \left[U_0 + jp \frac{kw}{\sqrt{2\pi}} U_1 \right]$$

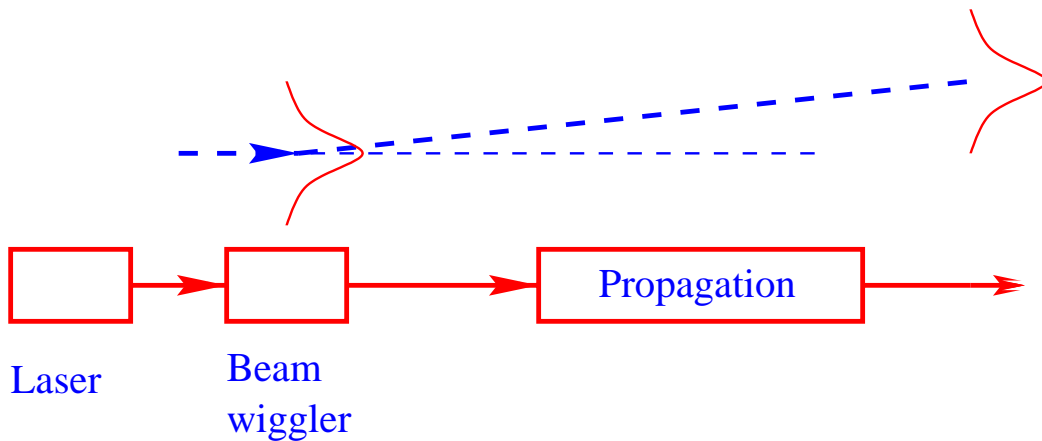
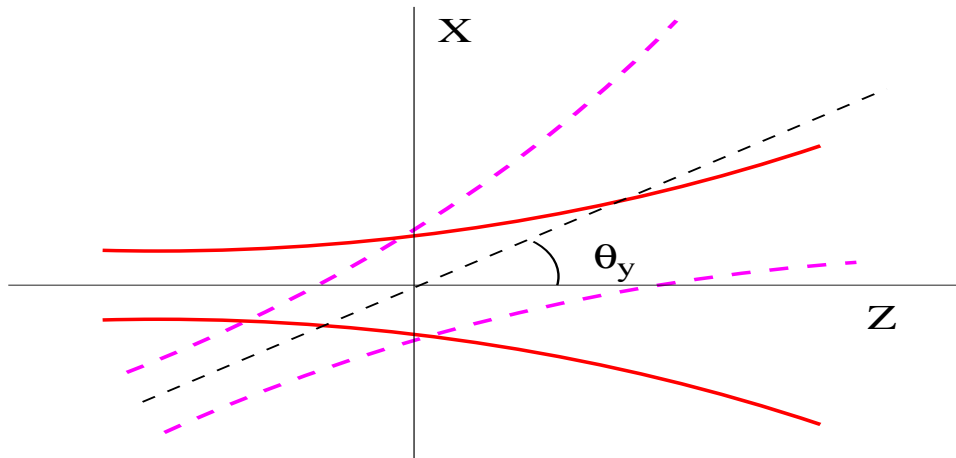

misalignment effects

- Beam-shifter : lateral displacement (d)

$$A \left[U_0 + \left(\frac{2}{\pi} \right)^{1/2} \frac{d}{w} U_1 \right]$$

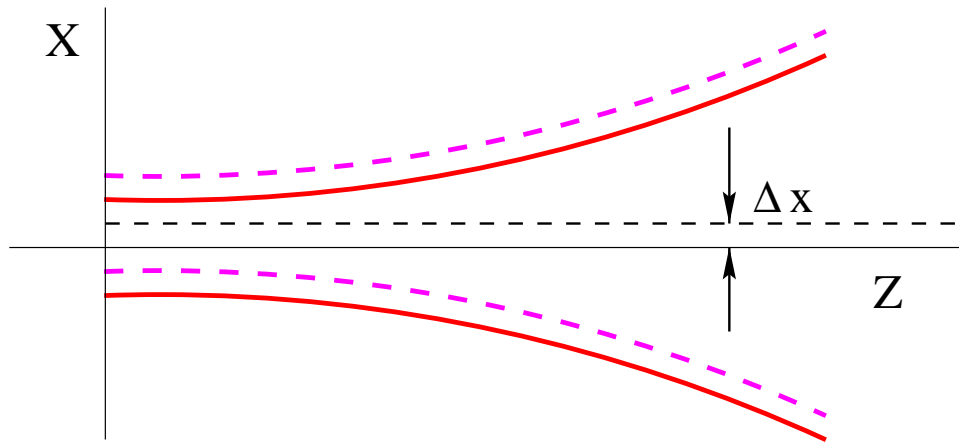

misalignment effects in Mirror

- mirror tilts : rotation (r) by an angle (pitch or yaw)

$$A \left[U_0 + jr \frac{k w}{\sqrt{2\pi}} U_1 \right]$$

- mirror's lateral shift : eqv. to rotation

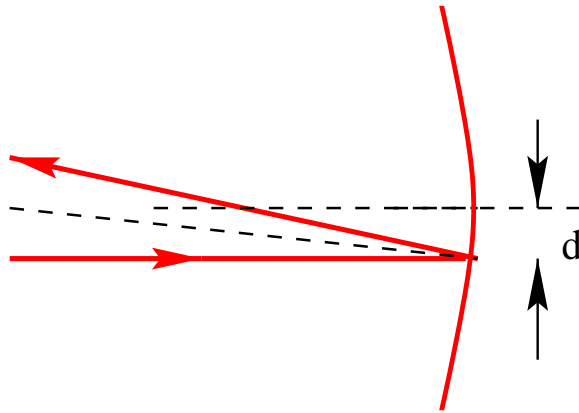

Mode Mismatch

›› Mode mismatch:

- change in waist size
- shift in beam position

›› Waist-position mismatch (b) :

$$A \left[U_0 + j \frac{b}{2kw^2} \{ U_0 + U_2 \} \right]$$

›› Waist-size mismatch (s) :

$$A \left[U_0 + \frac{s}{2w} U_2 \right]$$

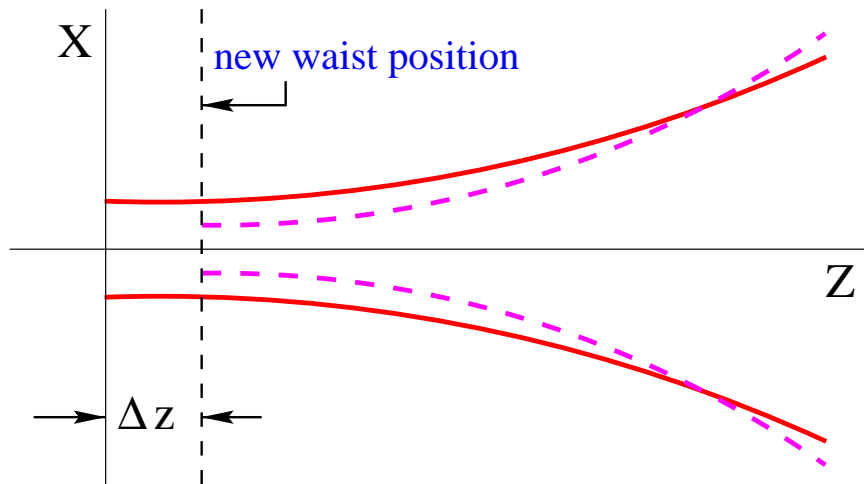

Mirror

Reflection and Transmission Operations

- Reflection Operation (of mirror) on 'field':
 - ›› multiplication by amplitude-reflectivity with appropriate sign
 - ›› changes in transversal modal-basis of the beam if reflected at an angle from a curved mirror
 - ›› appropriate phase factor for small longitudinal displacement
 - ›› a composite matrix representing small perturbations in mirror, like rotation, shift, mismatch between mirror surface and phase-front, etc.
 - ›› parity operation which flips the beam about vertical axis

- Transmission operation (of mirror) on 'field':
 - ›› multiplication by amplitude-transmissivity
 - ›› changes in transversal modal-basis of the beam (lensing)

Propagation

(prop and telescope)

- Effects (in vacuum)

- ›› longitudinal phase
- ›› gouy phase
- ›› change of basis (distance to waist changes)
- ›› time-delay

- telescope

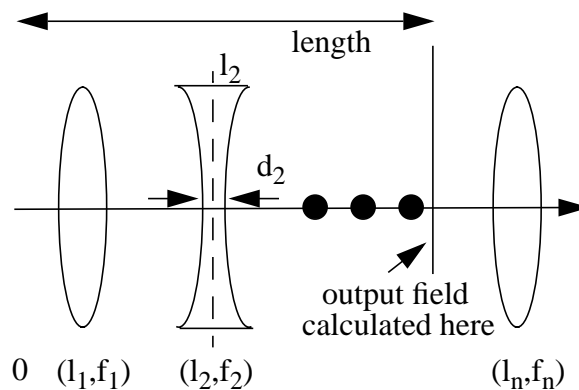

- ›› **Prop** module effects propagation thru vacuum and may or may not include time-delay (user's choice)
- ›› **Telescope** module can propagate light thru a series of lens placed in vacuum with all changes in guoy phases properly included
- ›› The **telescope** effect can also be specified by setting the basis and gouy phase information at the output instead of specifying details of lens & length

Composite Systems

(What are summation modules?)

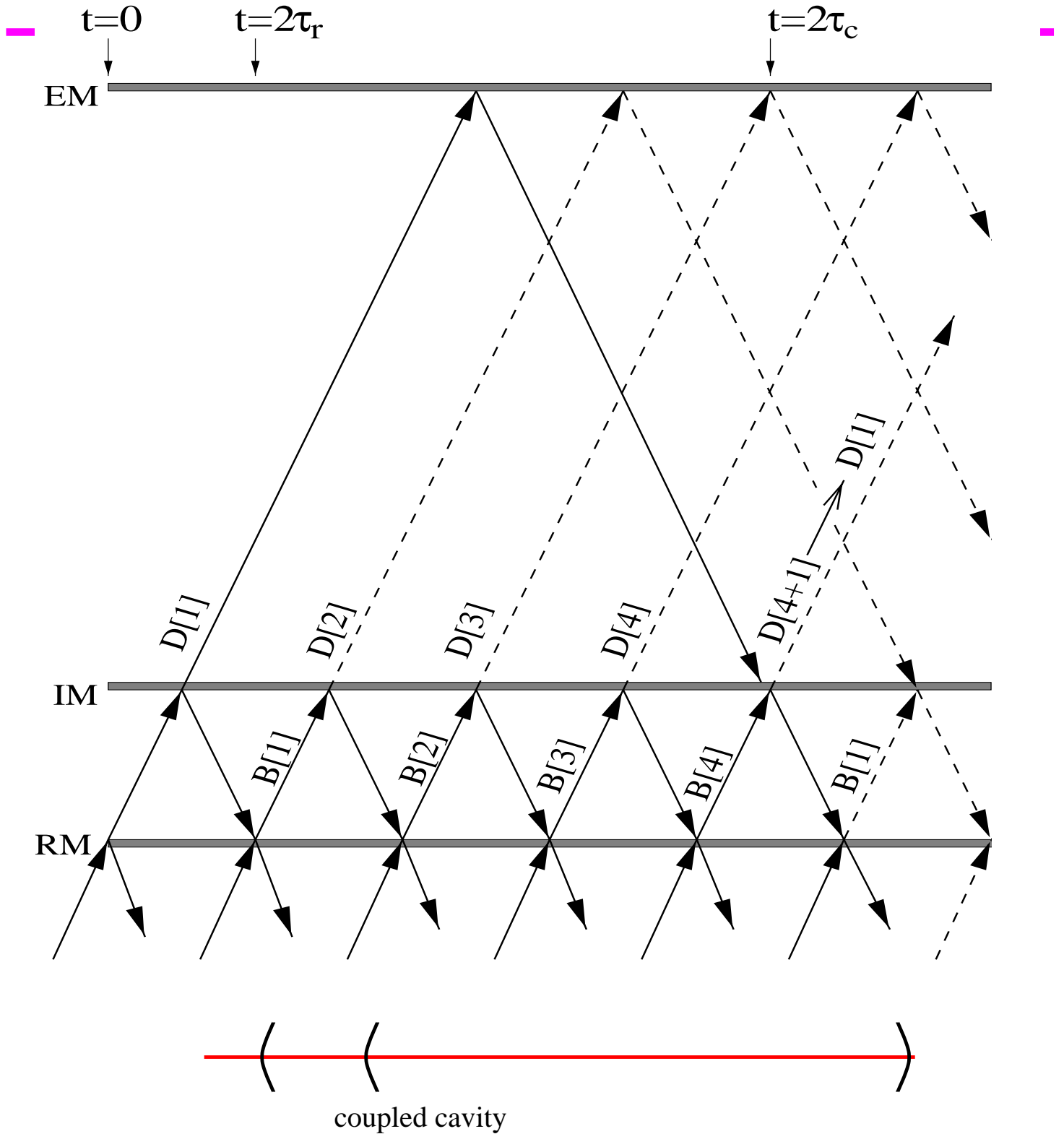

Composite Systems

(*summation modules*)

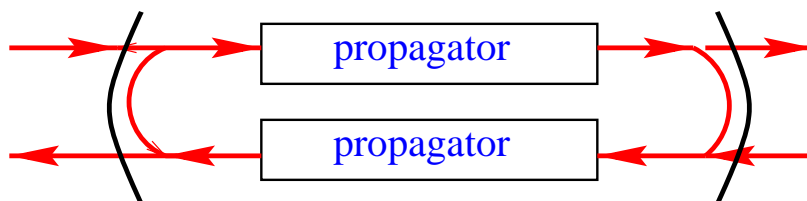

Using primitives: time-step = Length/speed of light

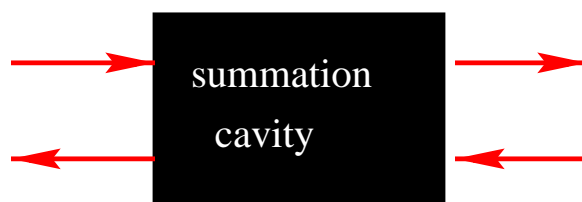

Using summation cavity:
time-step = $N \times$ Length/speed of light

- Three modules so far
 - ›› Fabry-Perot cav
 - ›› triangular cavity
 - ›› power-recycled Michelson cavity or the LIGO recycling cavity

Summation cavity in LIGO

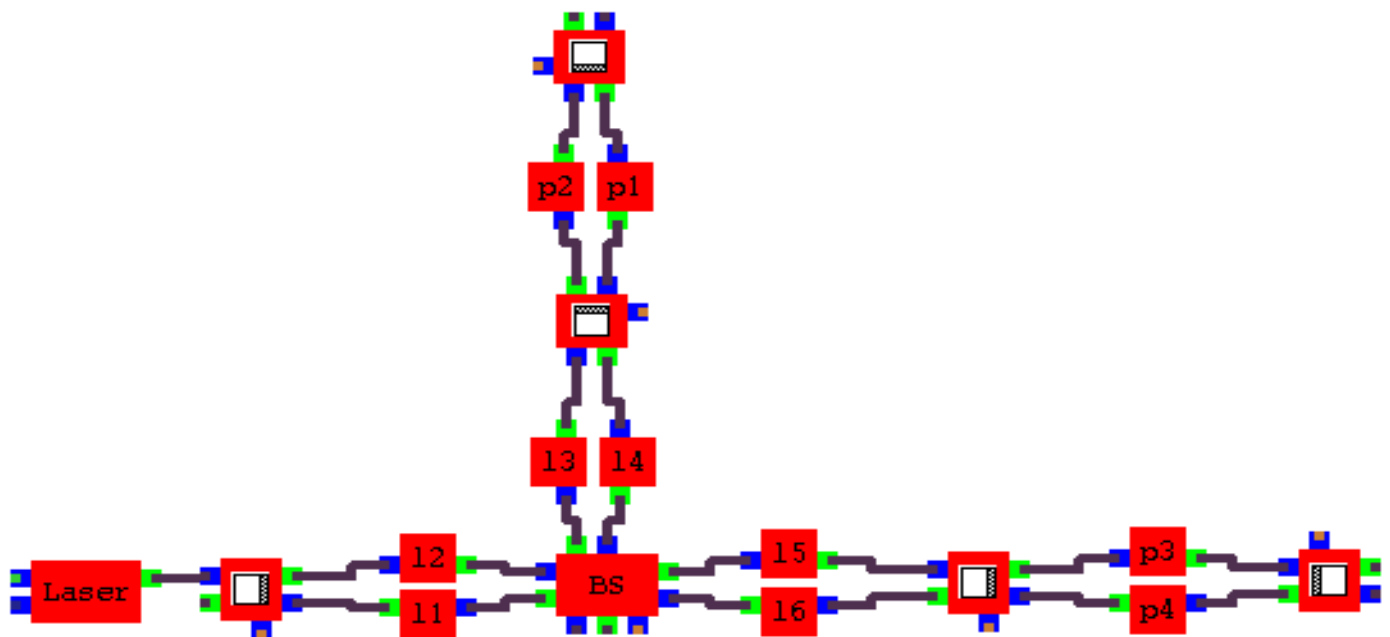
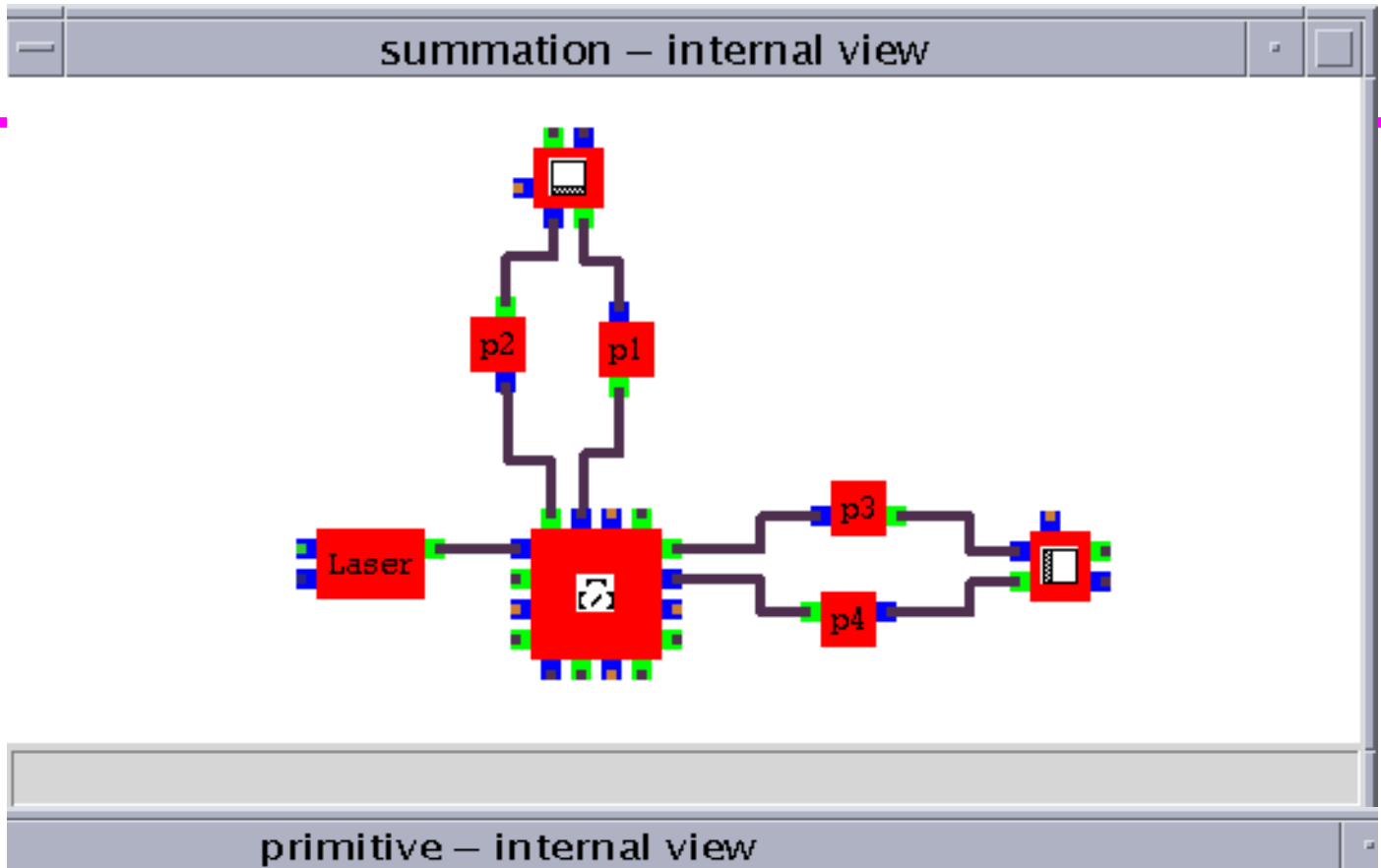

Triangular cavity

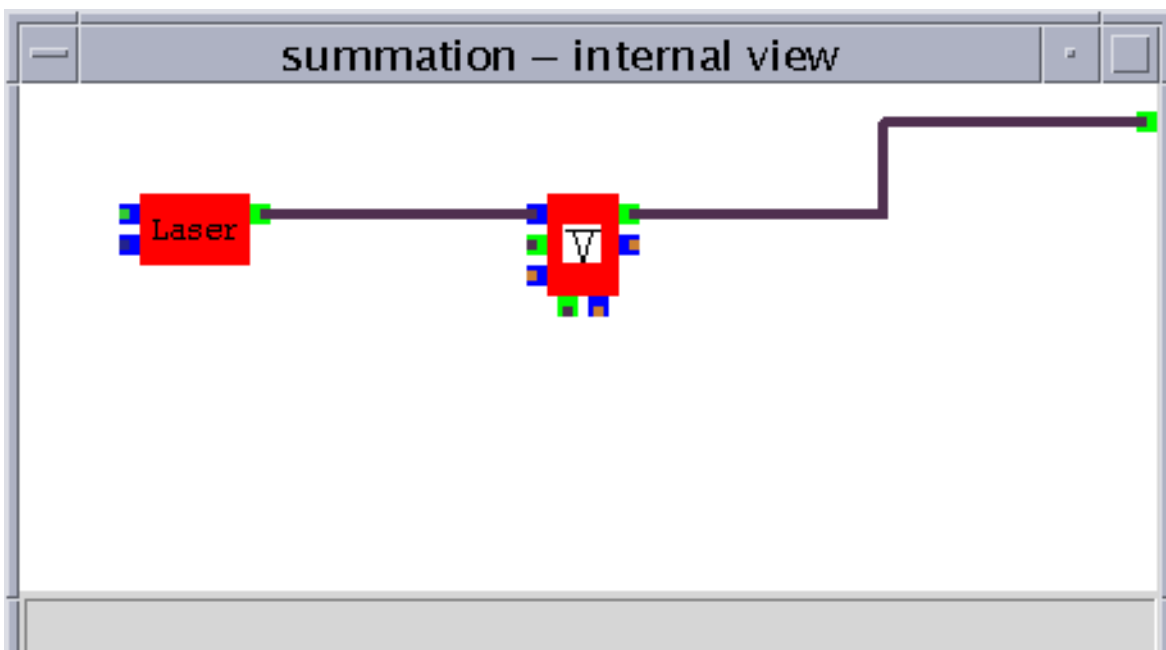
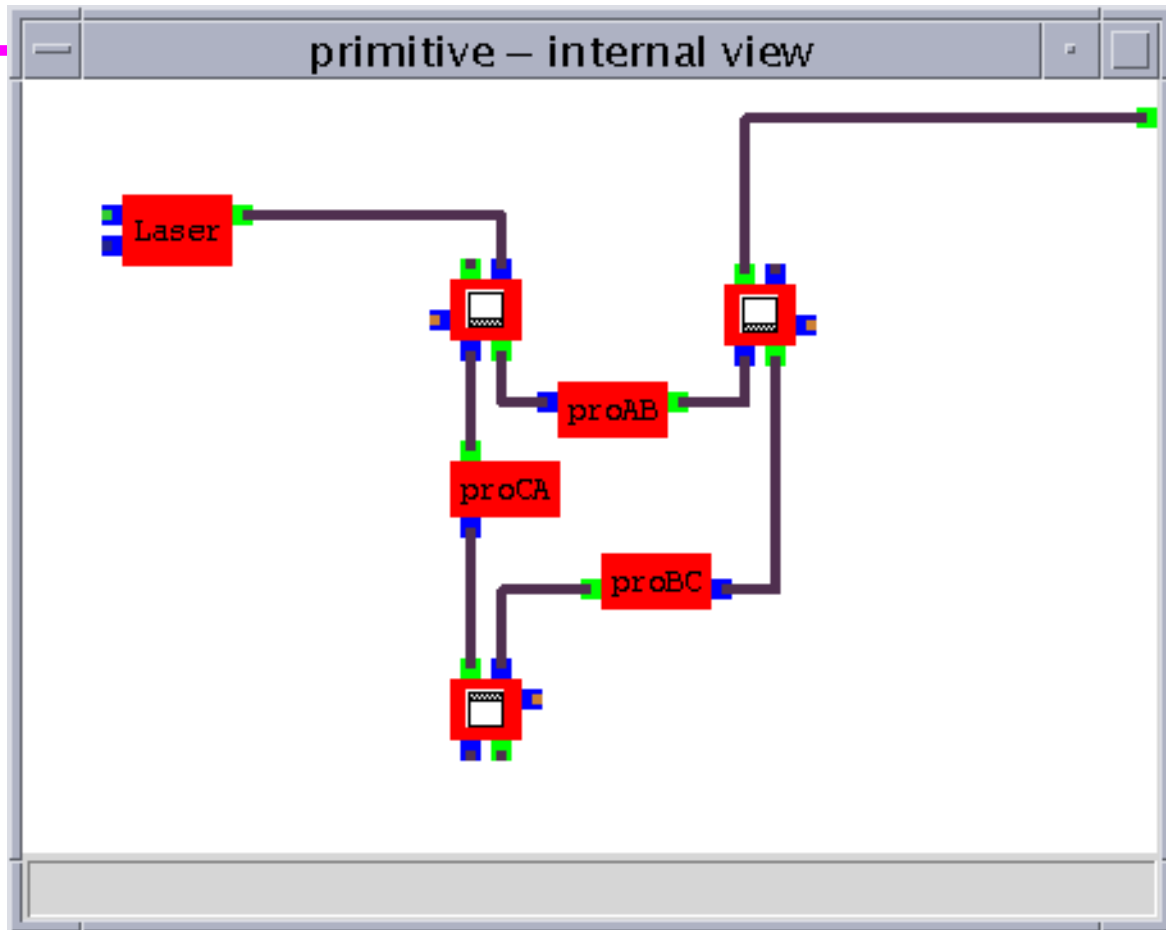

Digitizer

- ›› Analog data: discrete time-series of e_2e with small time-steps
- ›› Digitized data: sampled at larger time-steps (e.g. 16K circuit)

- Digital filter

- ›› characterised by poles, zeros, polepairs and zeropairs of equivalent analog filter
- ›› proper handling of data in discrete time-steps is done using z-transform internally
- ›› can be used as analog filter
- ›› to use in a digital circuit, it needs to be used in conjunction with ADC and DAC

ADC & DAC

- ADC

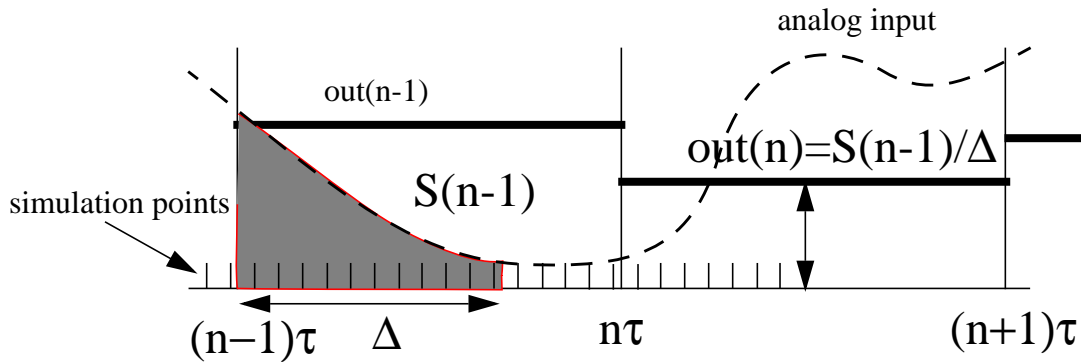

Figure 4: digitization in time

$$out(n\tau) = \frac{1}{\Delta} \int_{(n-1)\tau}^{(n-1)\tau + \Delta} input(t) dt$$

$$ADC(n\tau) = \text{floor}(\text{gain} \cdot out(n\tau) + 0.5)$$

›› output can be an integer in between limits specified by setting maximum no of bits

- DAC

Mechanics

>> susp3Dmass

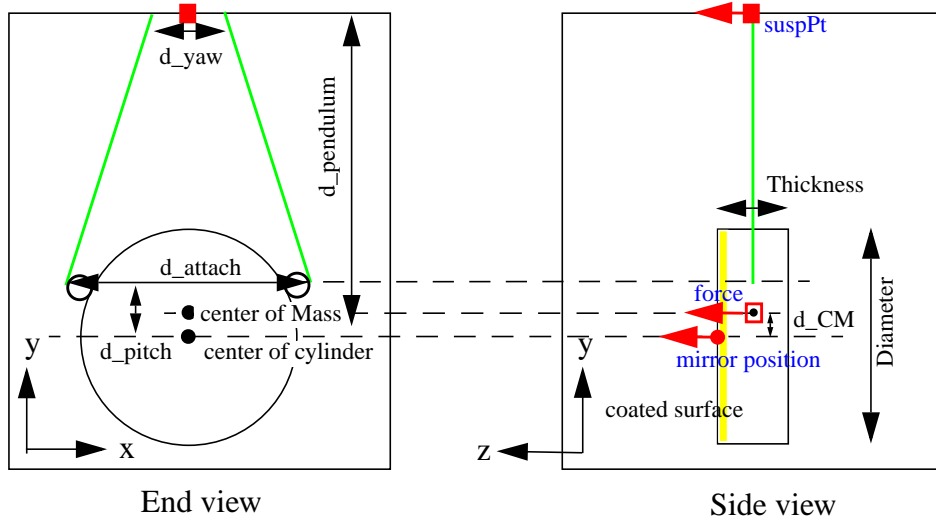

Figure 5: Single Suspended Mass

Coordinate system:

- AxisRotation

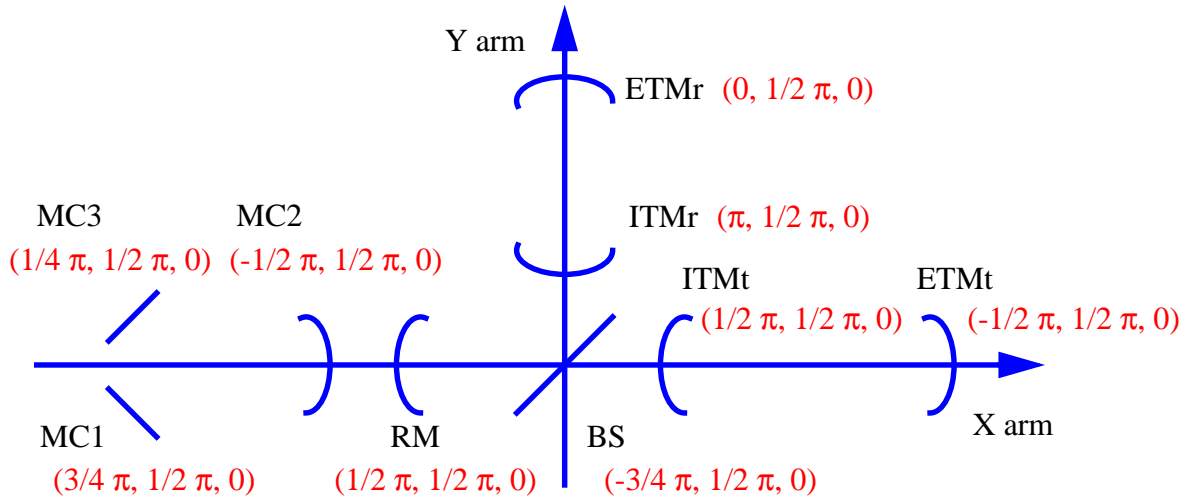

Figure 6: Detector to e2e coordinate transformation

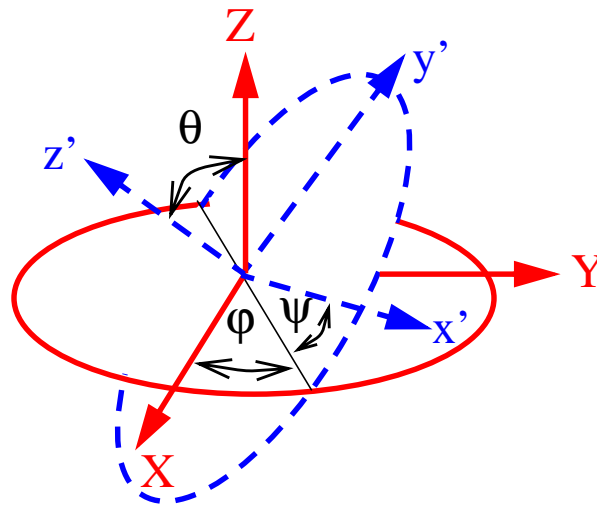

Figure 7: Euler angles

Math functions

- ›› algebraic: madder ($ax+by$), sine, square_root, inverse ...
- ›› logic : and,or,xor, $a>b$, not, flipflop, switch
- ›› limiter, delay, switch

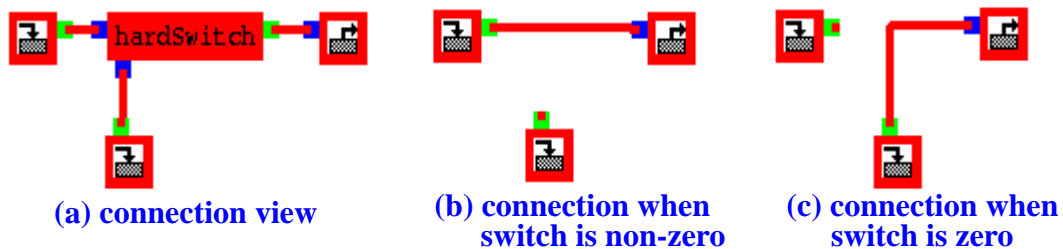

Figure 8: hardSwitch in action

- ›› In many cases, better to use FUNC()

Data

input and output

- generating inputs

- ›› clock (time) : may also use `get_time()` function in `Func()`
- ›› random number (normal)
- ›› random number (flat)
- ›› `data_in` : can get a data into simulation
- ›› `data_reader` : can read input data from an ascii file

- Output

- ›› `data_out` : can get a data out of the simulation ('probe')
- ›› `data_viewer`: view data at a particular instant
- ›› `psd_out`: accumulate input data, calculate psd and write to a file