

LVDT Measurements

v2.1 Board Schematics

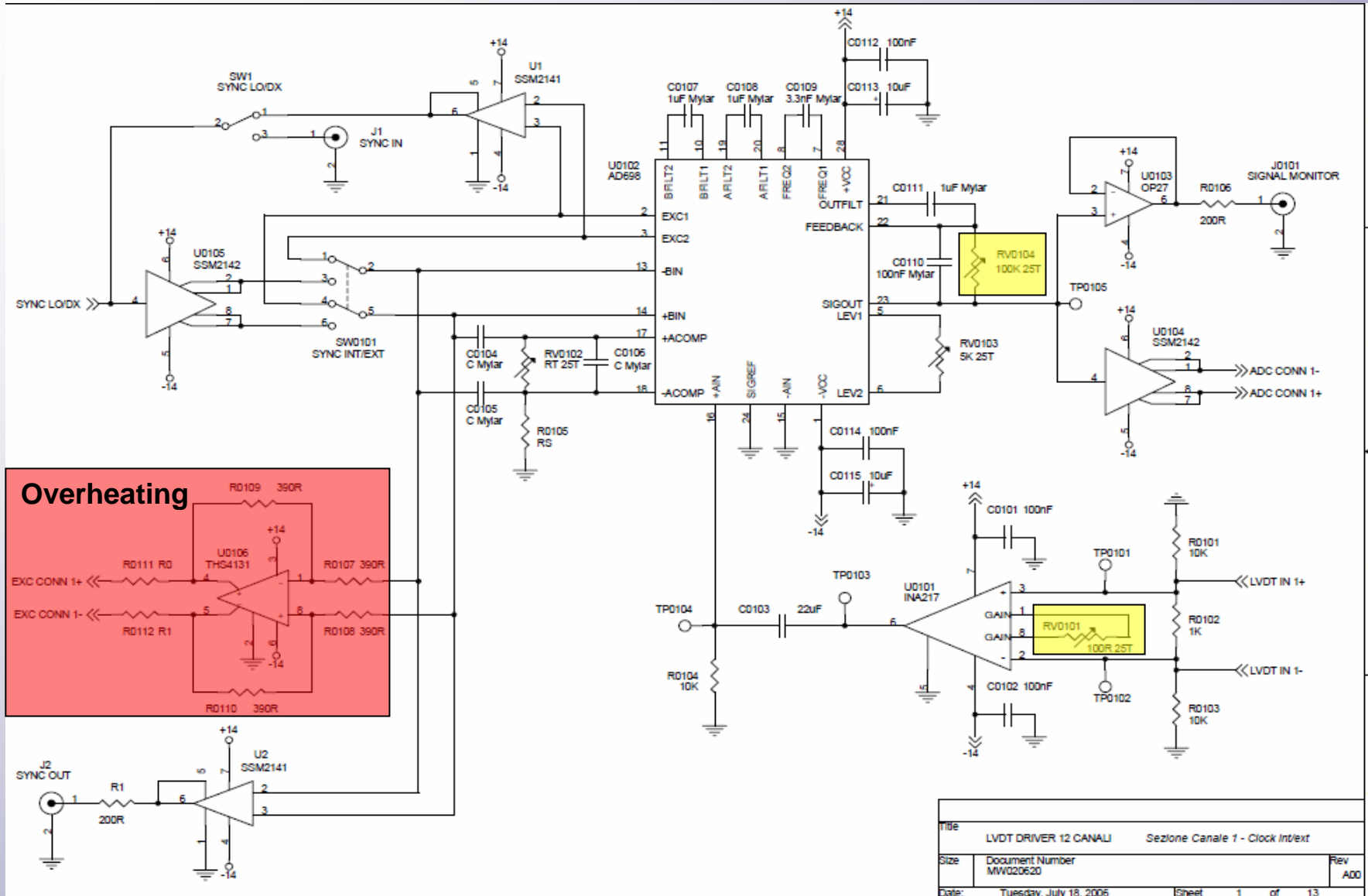



LVDT Measurements

v2.1 vs v2.0 Board Noise Comparison using Old Vertical LVDT

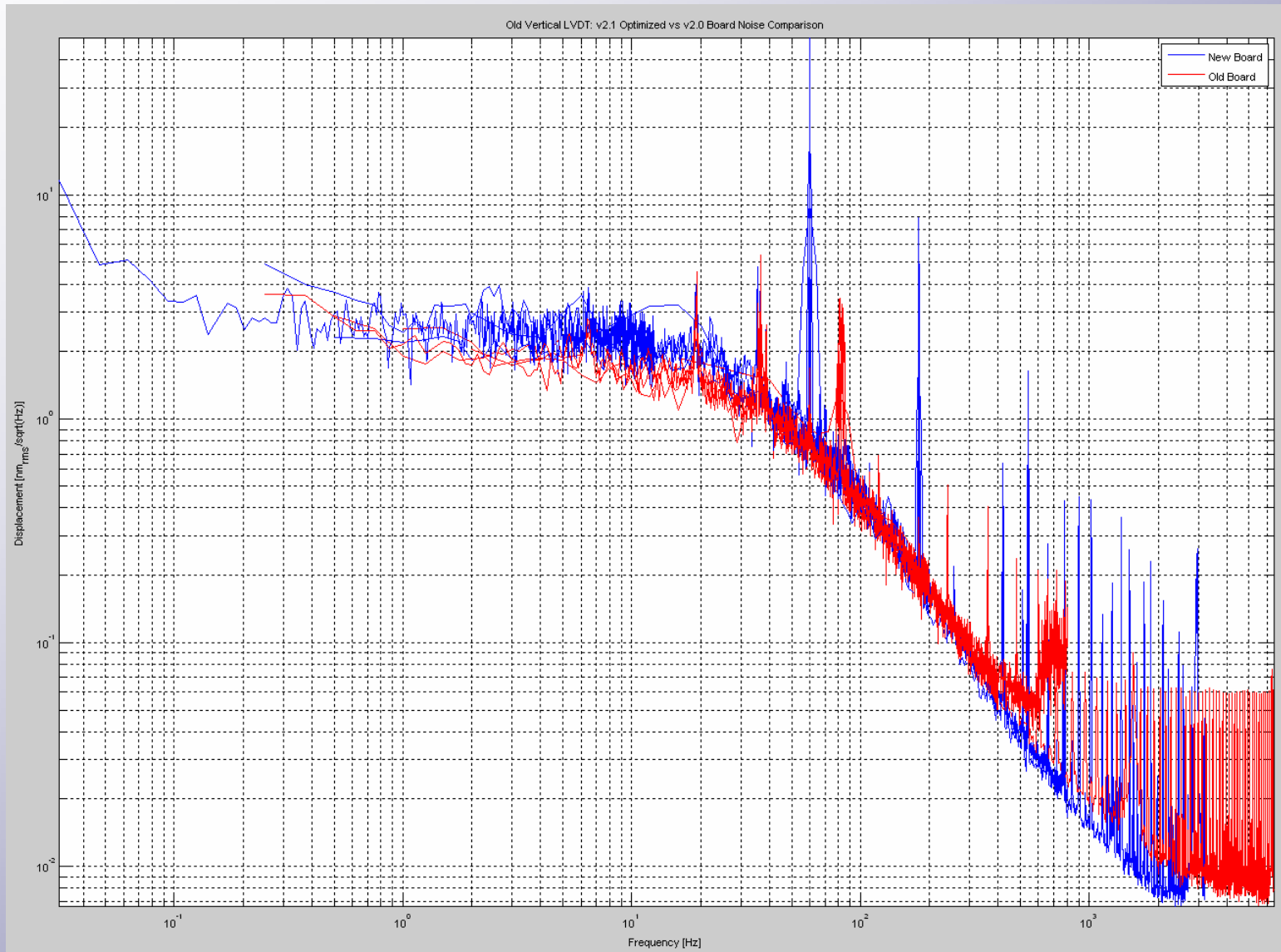



LVDT Measurements

Summary

	v2.0 Board (Old LVDT)	v2.1 Board (Old LVDT)
Calibration factor:	0.179 mm/V	0.127 mm/V
Residual displacement noise:	1.7 nm rms/sqrt(Hz)@2Hz	2.5 nm rms/sqrt(Hz)@2Hz
Dynamic range:	± 2 mm	± 2.5 mm