

DC Readout Experiment at the Caltech 40m Laboratory

Robert Ward

Caltech

Amaldi 7

July 14th, 2007

the 40m team:

Rana Adhikari, Benjamin Abbott, Rich Abbott, Rolf Bork, Darcy Barron, Tobin Fricke, Valery Frolov, Jay Heefner, Alexander Ivanov, Osamu Miyakawa, Kirk McKenzie, Royal Reinecke, Bram Slagmolen, Michael Smith, Bob Taylor, Stephen Vass, Sam Waldman, and Alan Weinstein

Caltech 40 meter prototype interferometer (*mini-LIGO*)

The Mission:

- Prototype the Advanced LIGO Length and Alignment **Controls**

- Develop **DC readout scheme**

- DC Readout is the baseline GW signal extraction technique for eLIGO & aLIGO

- Characterize noise mechanisms

- Gain confidence in modeling

- Testbed for AdLIGO *controls technologies*

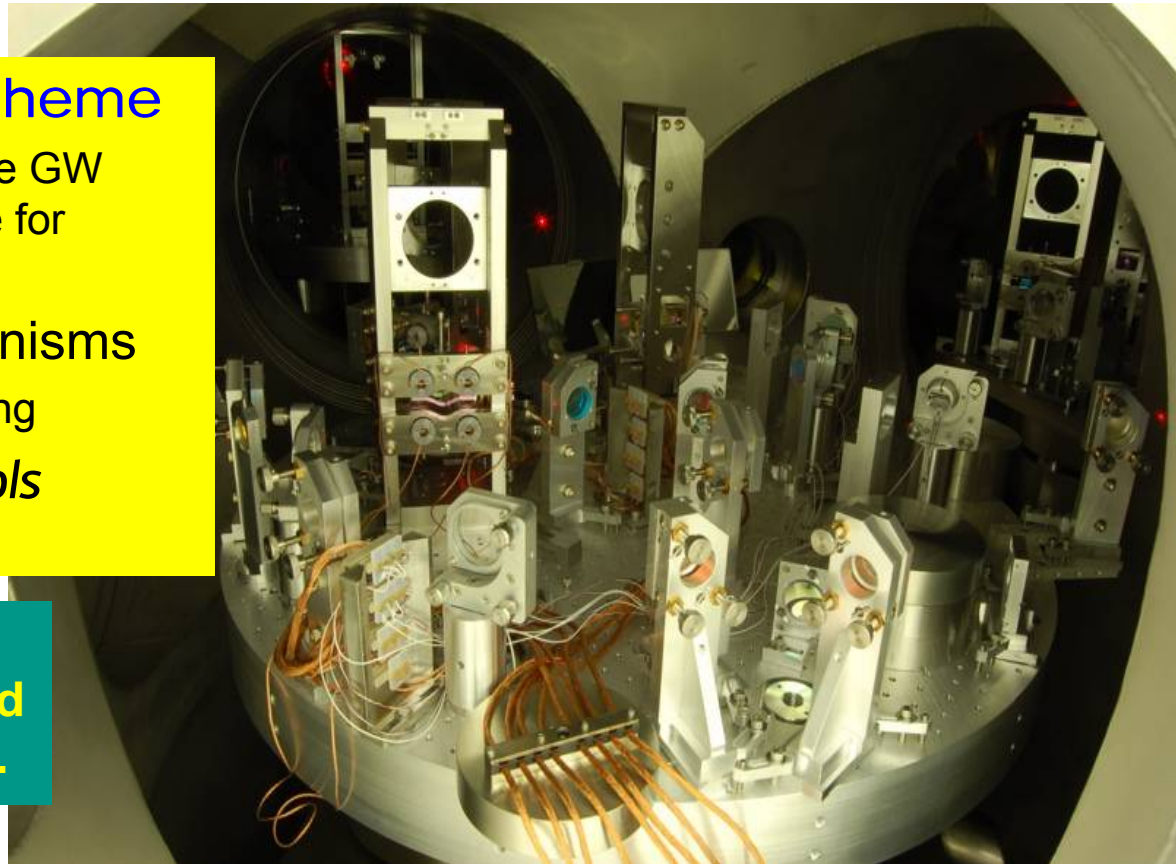

Prototyping will yield crucial information about how to build and run AdLIGO (and eLIGO).

Gravitational Wave Signal Extraction: RF and DC Readout

RF Readout

At the dark fringe, the asymmetric port power is quadratic in DARM—so we must use RF sidebands as a local oscillator to get a signal proportional to DARM (GW strain).

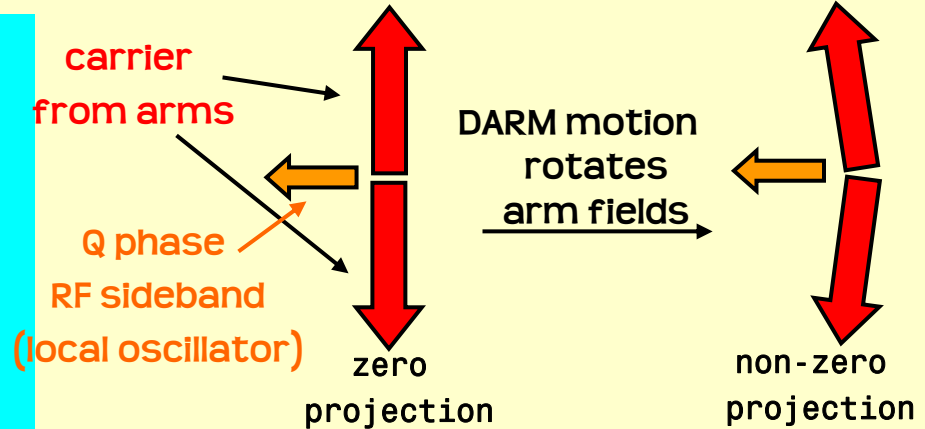

AS Power

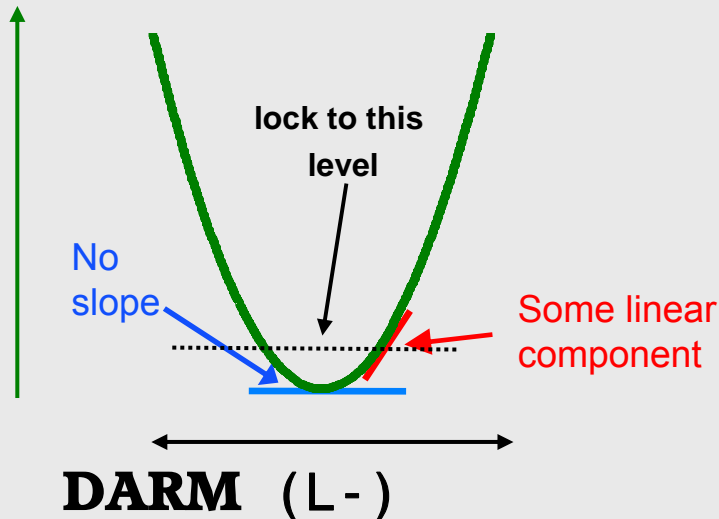

DC Readout

Offset the differential arm degree of freedom (DARM) slightly from the dark fringe. Asymmetric port power is now proportional to GW strain. No more RF sidebands.

Why DC Readout?

- DC Readout can have lower shot noise
 - homodyne shot noise is lower than heterodyne shot noise
- DC Readout can also reduce susceptibility to **laser noises** and **technical noises** (mainly due to the RF sidebands):

- ❖ **laser noise** (intensity & frequency)
- ❖ **oscillator noise** (amplitude & phase)
- ❖ **photodetector saturations** (no more AS_I current)
- ❖ **effects of unstable recycling cavity:**
 - junk light
 - imperfect spatial overlap of local oscillator and GW signal fields

RF Sideband Field
(local oscillator)

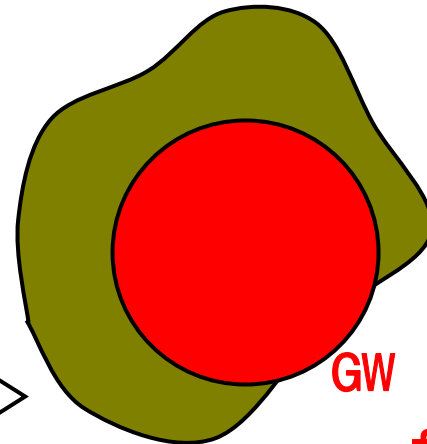

GW signal
field

Perfecting the spatial overlap: cleaning the modes

AS PORT Before OMC

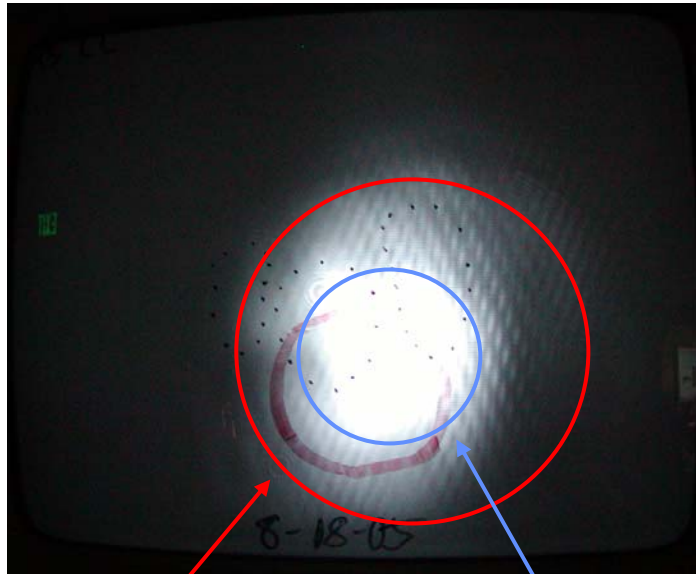

RF local oscillator
+
junk light

signal field

OMC Transmitted

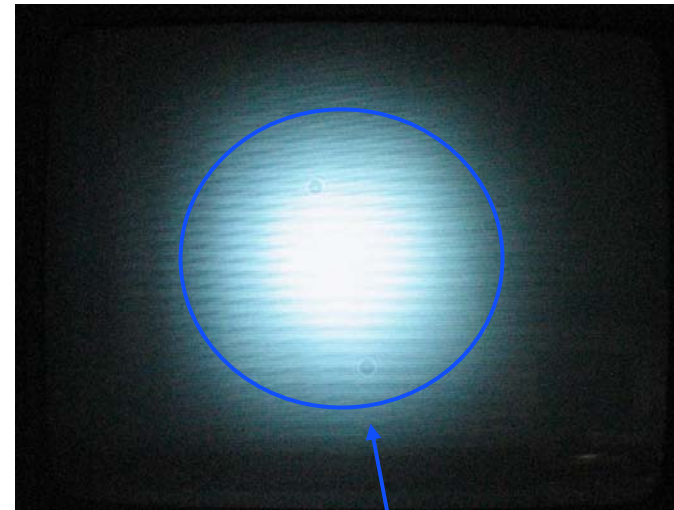

DC local oscillator
+
signal field

Better Signal Detection: Output Mode Cleaner

- OMC removes most of the junk light→no more photodetector saturations, less shot noise, and no more spatial overlap problem
- DC Readout requires an in-vacuum, seismically isolated output mode cleaner and photodetector
- New noise sources include OMC length and alignment noise

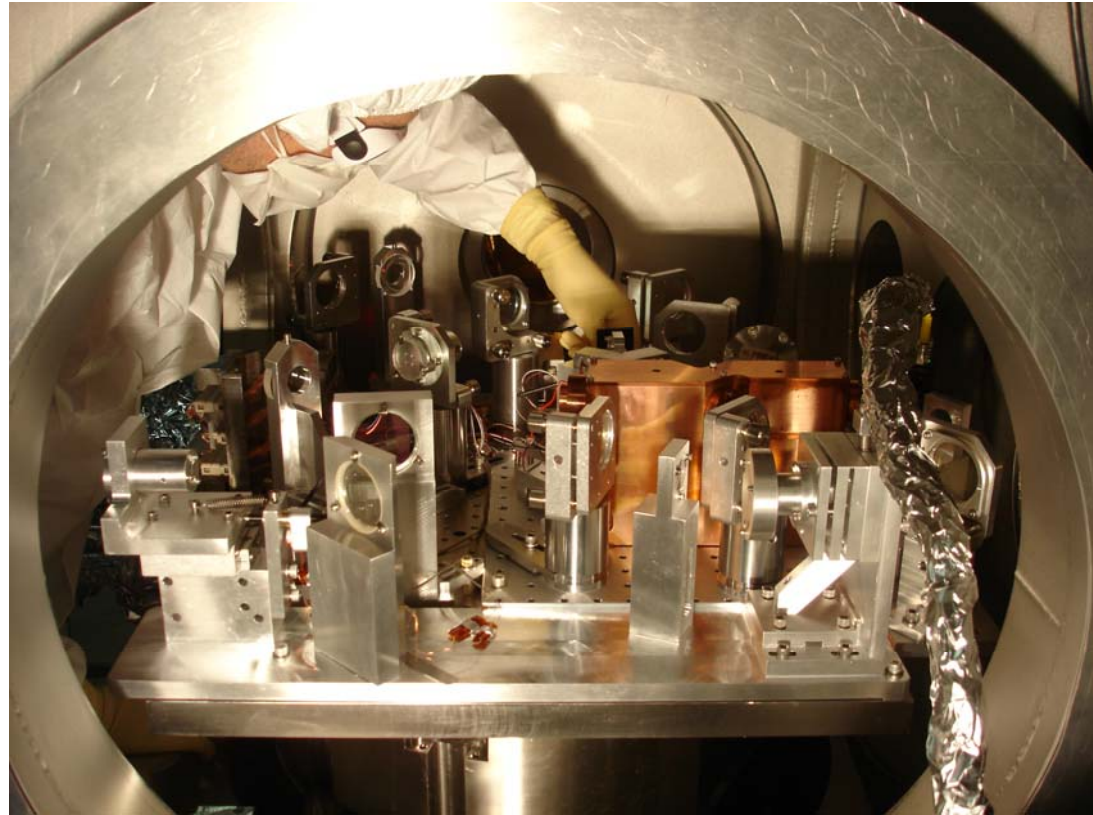

Caltech 40m

Prototyping for eLIGO: Power Recycled Fabry Perot Michelson

- Fully instrumented prototype
- Initial LIGO-style single pendulums
- Initial LIGO digital control system, interfaced with aLIGO style subsystem for DC Readout
- OMC length and alignment controlled digitally via dither locking

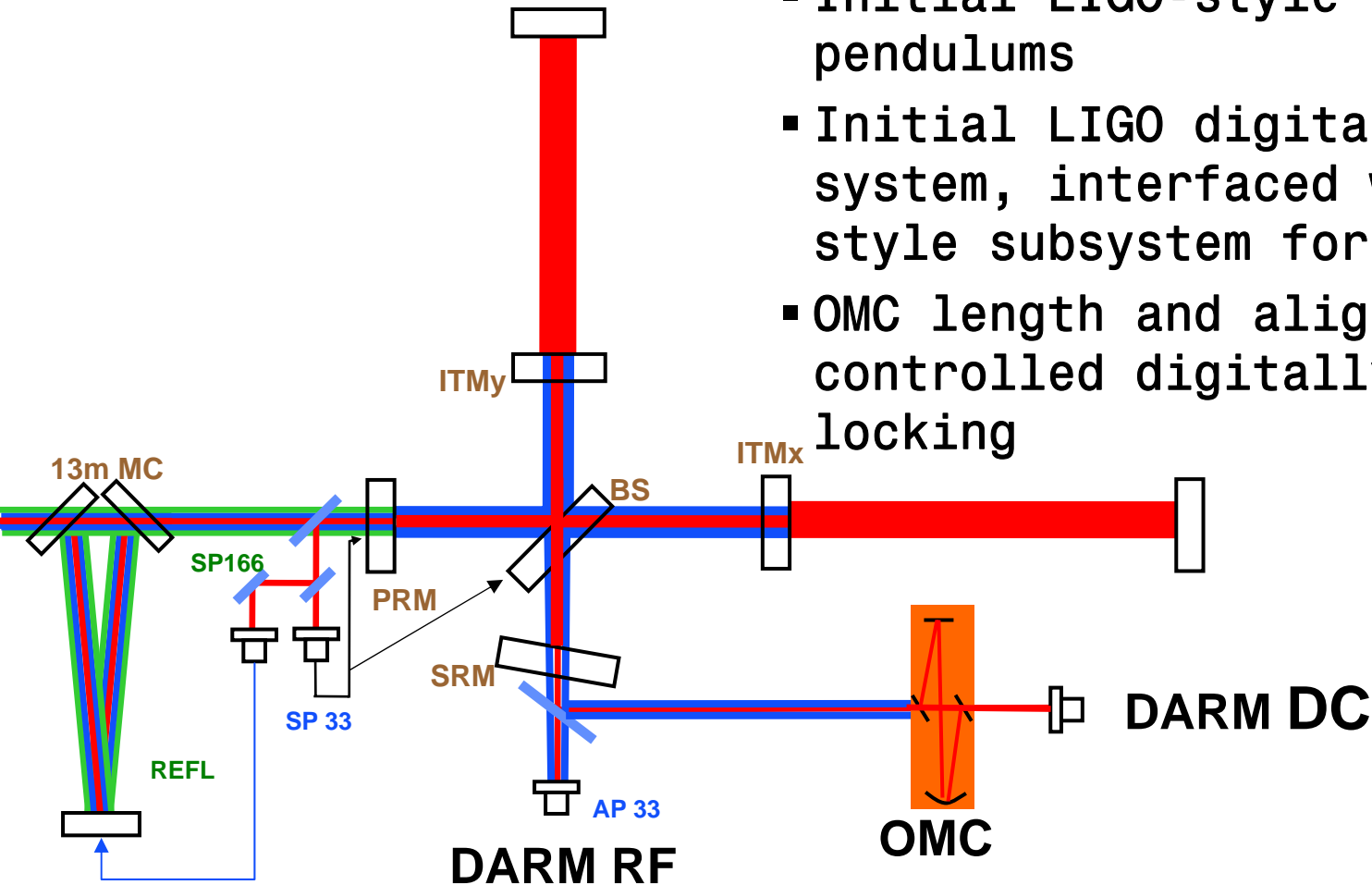

DC Readout @ Caltech 40m

- Monolithic, 4-mirror output mode cleaner
 - » finesse: 210
 - » 92% transmission
 - » 4-mirrors to reduce accidental HOM resonances
- Pair of PZT-driven tip/tilt steering mirrors for input to OMC
- In-vacuum photodetector with electronic preamplifier
- On a seismic isolation stack
- Beam picked off before OMC for an RF sensing chain for comparisons & lock acquisition

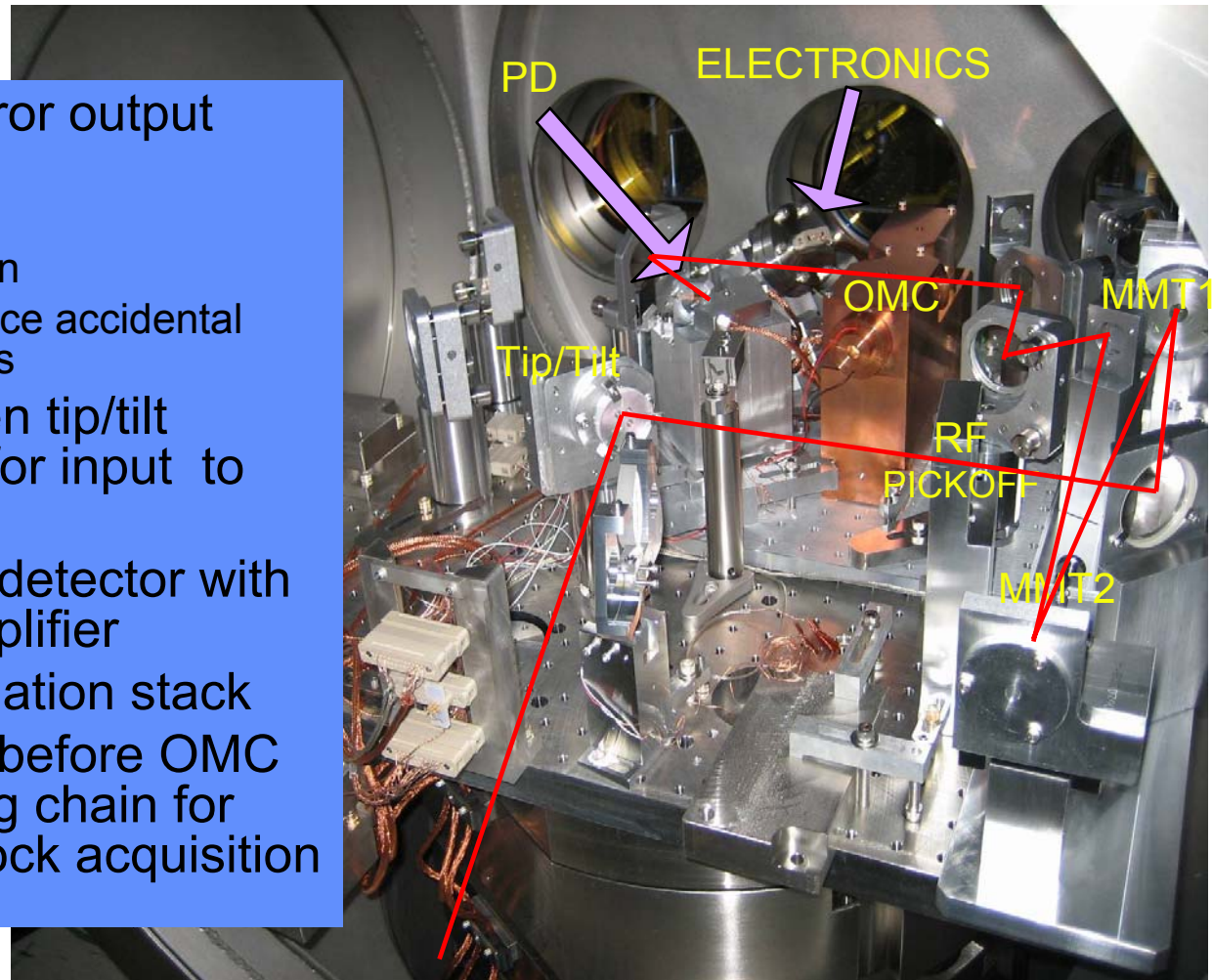

- RF – AS_Q :

$$AS_Q \propto \delta L - * RIN + RIN * \delta f_c / f_c \text{ (rad. pres.)}$$

- DC – AS_DC is first order sensitive to AM:

$$AS_DC \propto RIN$$

- RF – sidebands transmitted to the dark port unfiltered (only a 4 kHz MC pole)

- DC – carrier filtered by the coupled PR-Arm cavity

» Use the IFO to filter laser noise

Intensity Noise Coupling

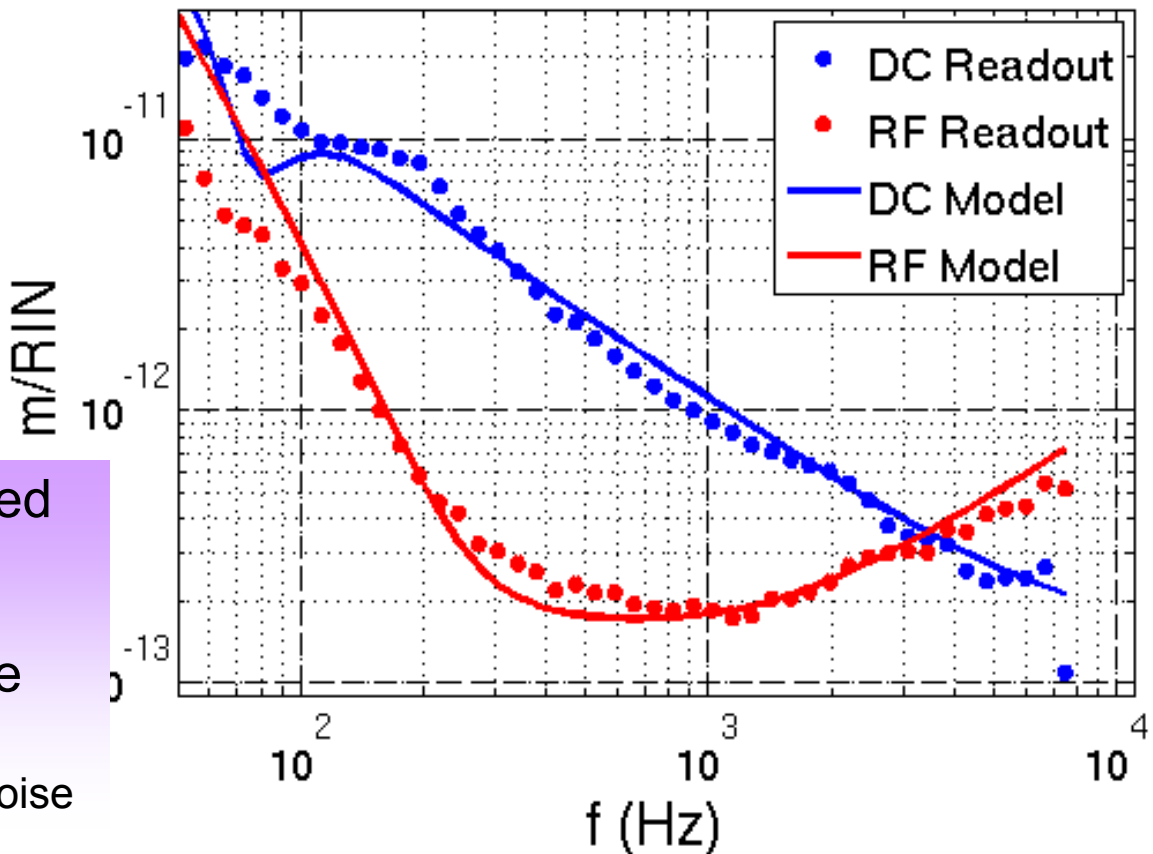

- RF – audio noise sidebands beat with the carrier contrast defect:

$$AS_Q \propto C_D * \delta v$$

- DC – arm cavity pole imbalance couples carrier frequency noise to dark port

$$AS_{DC} \propto \delta f_c / f_c$$

- RF – sidebands transmitted to the dark port unfiltered (only a 4 kHz MC pole)
- DC – carrier filtered by the coupled PR-Arm cavity

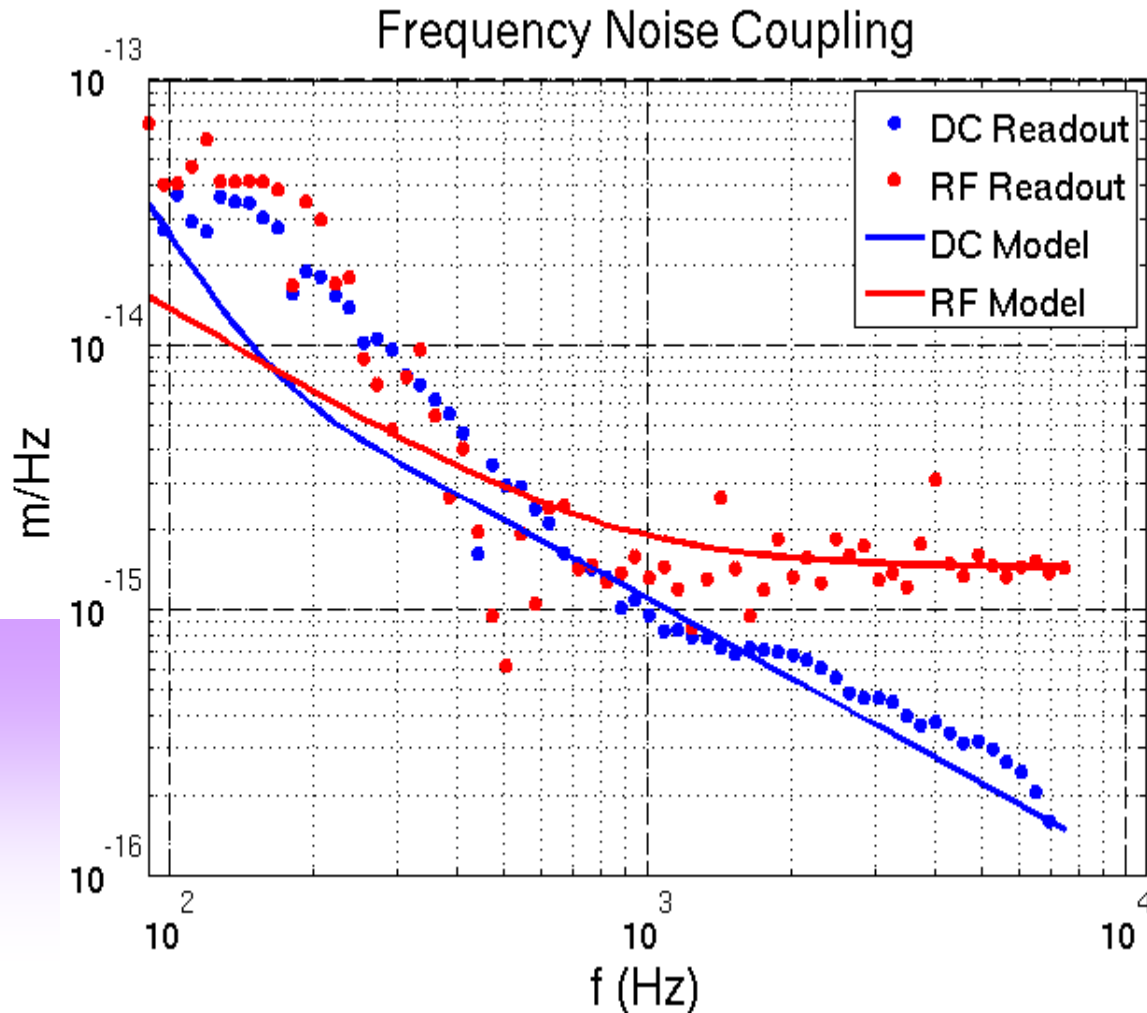

Oscillator Phase Noise

- RF – Not completely understood. Something to do with sideband imbalance and higher order modes somewhere.
- DC – Some coupling through finite finesse of OMC and maybe through aux. LSC loops (CARM, MICH, PRC). Closed loop modeling tools under development.

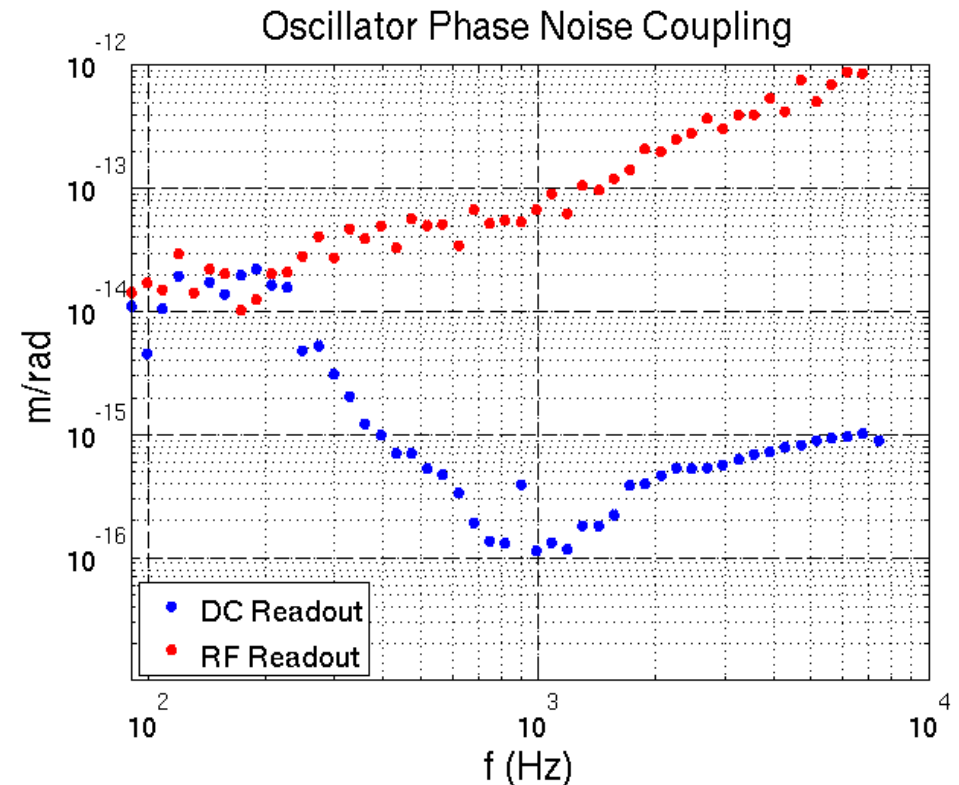

- RF – sidebands transmitted to the dark port unfiltered (only a 4 kHz MC pole)
- DC – sidebands rejected by OMC

Oscillator Amplitude Noise

- RF – very similar to laser AM (looks like a gain modulation). Below SRD level with the existing crystal oscillators ($\delta A/A < 10^{-8}$)
- DC – can show up as intensity noise (oscillator steals power from the carrier)

- RF – sidebands transmitted to the dark port unfiltered (only a 4 kHz MC pole)
- DC – sidebands rejected by OMC

Oscillator Amplitude Noise Coupling

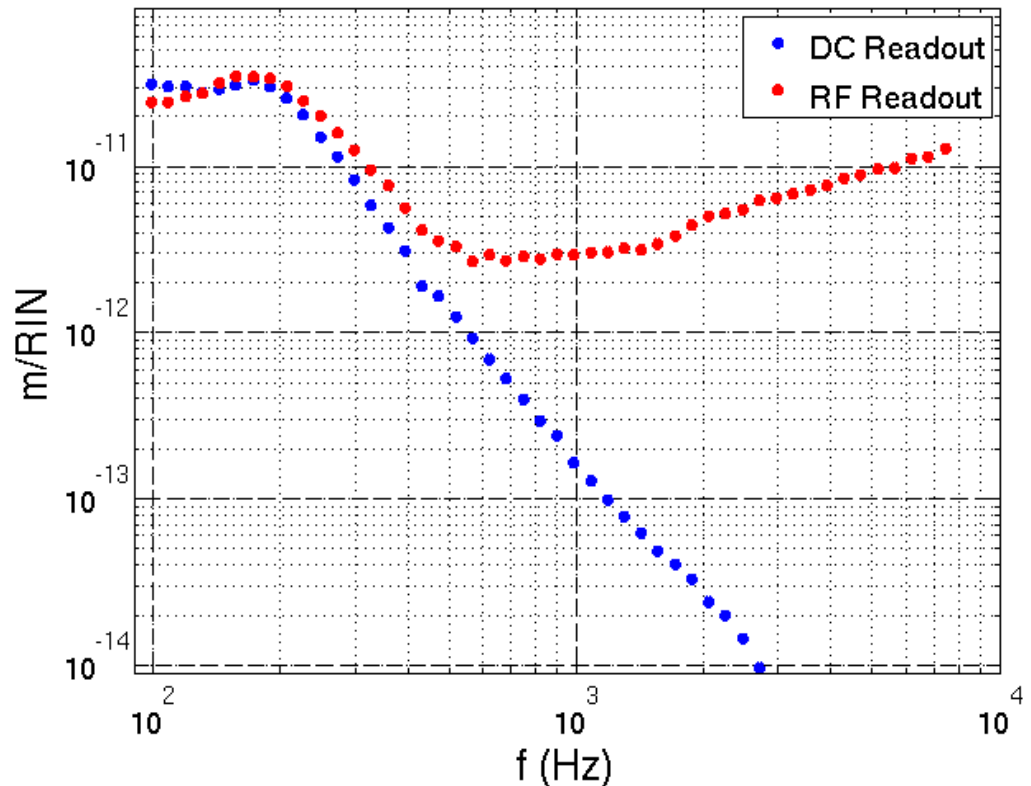

DARM offset
~25pm

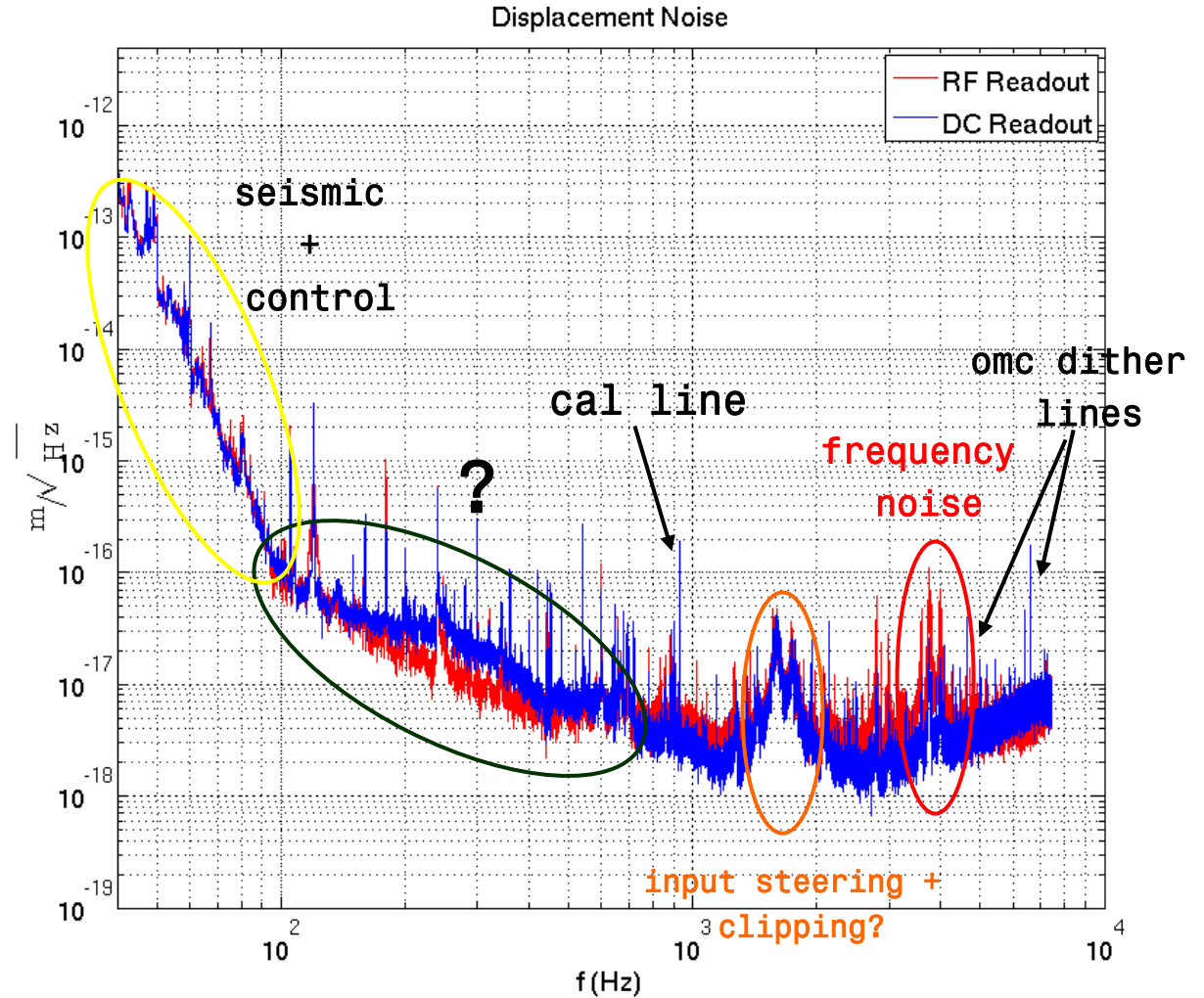

Preliminary Noise Budgeting

Displacement Noise DC Readout

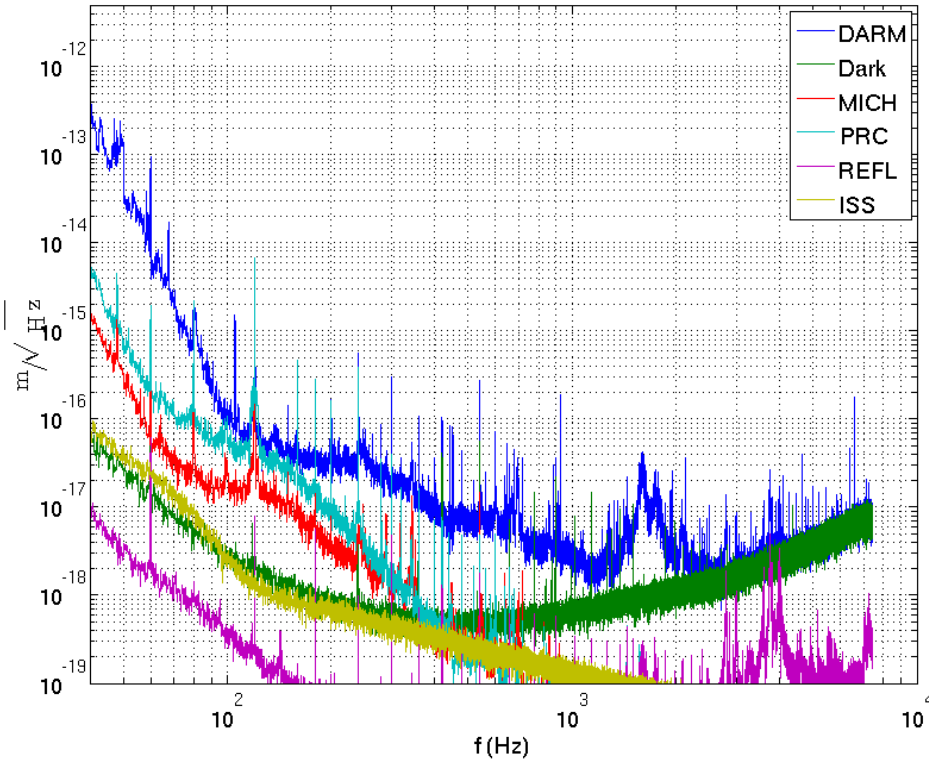

Displacement Noise RF Readout

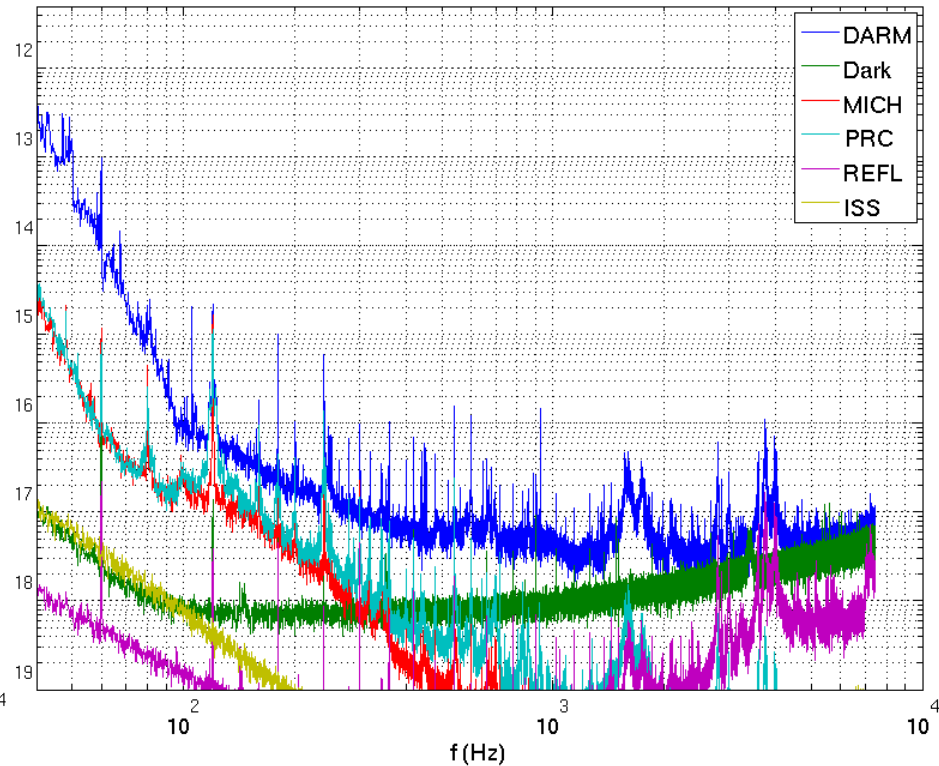

coming attractions

- DC Readout on a tuned-RSE 40m
- A similar DC Readout system will be installed as part of Enhanced LIGO
- 40m will be re-configured (optics recoated/polished, cavity lengths changed) to prototype the new aLIGO sensing scheme.

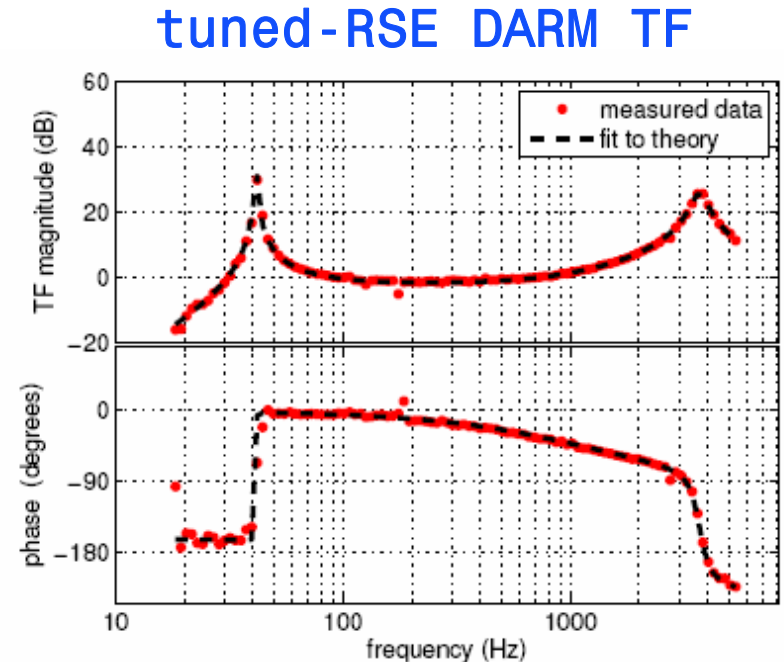
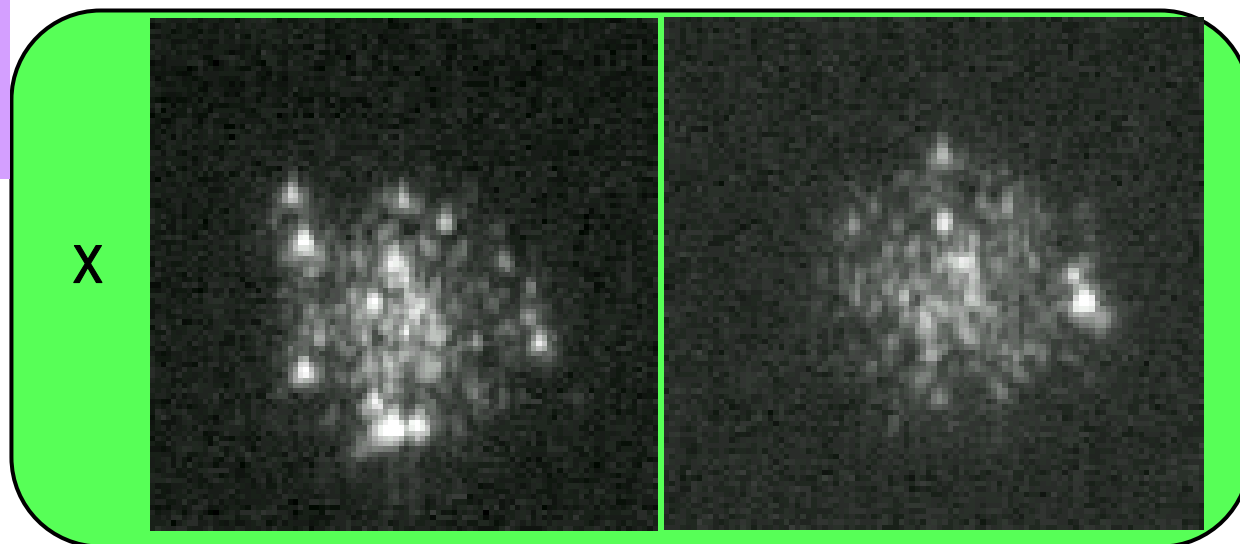
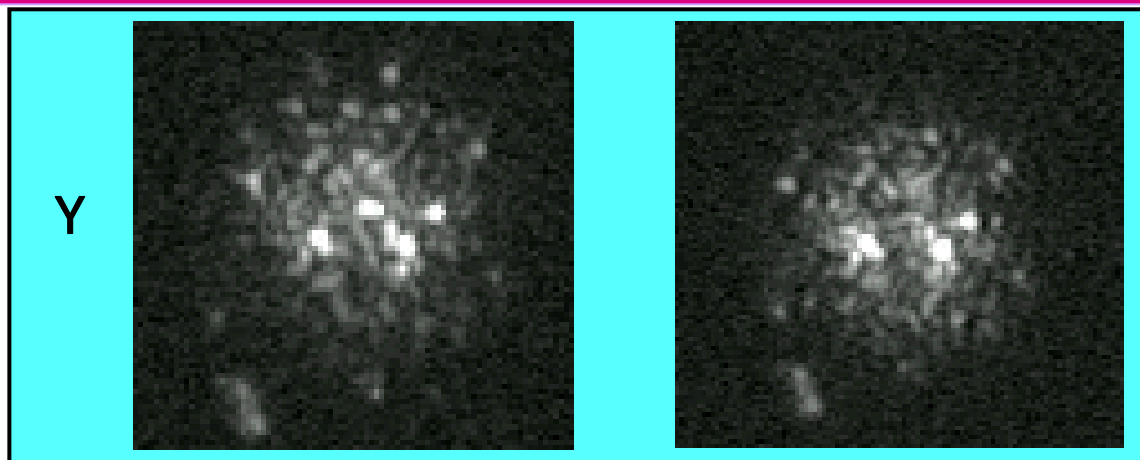

FIG. 3: The magnitude (top) and phase (bottom) response
Miyakawa *et al*, Phys. Rev. D74, 022001 (2006)

Cleaning the Optics

Vented the vacuum in June to try cleaning the End Test Masses. Saw a 50ppm loss reduction in the X-arm cavity (no change in the Y-arm cavity)



Before

After

Frequency Noise After Cleaning the Optics

- For RF readout, the dominant frequency noise coupling is due to the arm cavity loss mismatch creating a static carrier field at the signal port, which beats against noise on the RF sidebands. The outcome of the cleaning was to reduce the mismatch, thus reducing the coupling.

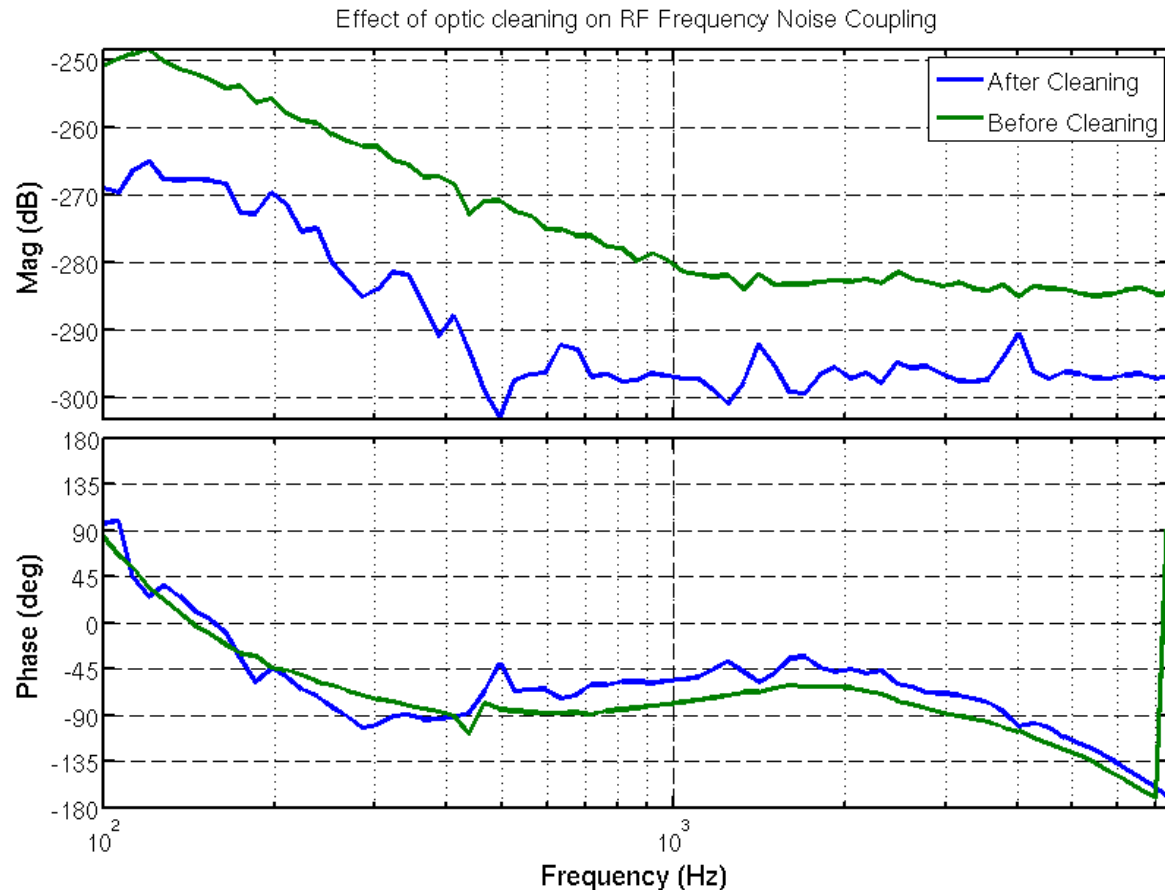

DC Readout at LLO

~1 Mpc Inspiral Range

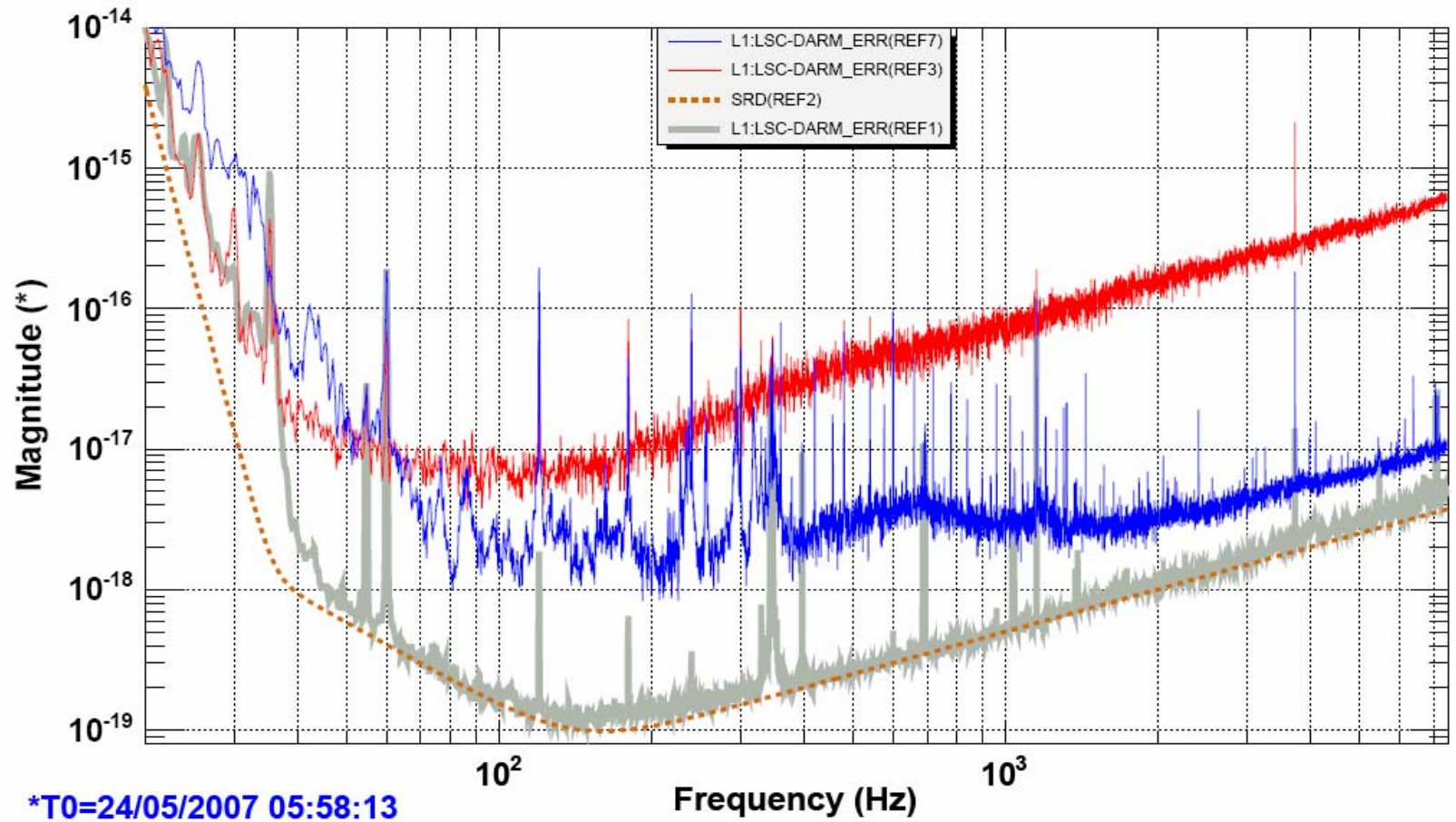

OMC controls system

- **Advanced LIGO style digital controls system**
 - » **PCIX based controls, interfaced successfully with current LIGO-like VME ISC control system. This result is important for eLIGO.**
- **OMC Controls**
 - » All DOFs digitally dithered and demodulated.
 - » OMC Length dither **locked** (dither freq 12kHz, UGF 100Hz)
 - dither amplitude ~ 5 pm
 - OMC Alignment Sensing & Control
 - dither **locked** (two tip/tilts, 4 DOFs)
 - dither freqs ~4 - 7 kHz
 - servo bandwidth: 2@20Hz, 2@subHz
 - dither amplitude ~ 5 urad (?)