

LASER INTERFEROMETER GRAVITATIONAL WAVE OBSERVATORY
-LIGO-
CALIFORNIA INSTITUTE OF TECHNOLOGY
MASSACHUSETTS INSTITUTE OF TECHNOLOGY

Technical Note	LIGO-T030149- 00- R	07/29/03
-----------------------	----------------------------	----------

<p>Configuration Study of Pre-Mode Cleaner and Reference Cavity in the 40m PSL System</p>
--

Seiji Kawamura

This is an internal working note
of the LIGO Project.

California Institute of Technology
LIGO Project – MS 51-33
Pasadena CA 91125
Phone (626) 395-2129
Fax (626) 304-9834
E-mail: info@ligo.caltech.edu

Massachusetts Institute of Technology
LIGO Project – MS 20B-145
Cambridge, MA 01239
Phone (617) 253-4824
Fax (617) 253-7014
E-mail: info@ligo.mit.edu

WWW: <http://www.ligo.caltech.edu>

ABSTRACT

The LIGO Pre-Stabilized Laser (PSL) system consists of a Laser, a reference cavity and its servo system, and a pre-mode cleaner and its servo system. In the LIGO PSL system the light is picked off for the reference cavity before the pre-mode cleaner. An alternative way is to pick off the light for the reference cavity after the pre-mode cleaner. These two configurations are compared in terms of the loop gain, the frequency stabilization, the effect of the resonant frequency of the cavities, and the effect of the noise in the cavity servo systems. It was found that it is advantageous to pick off the light after the pre-mode cleaner to suppress the effect of the variation in the resonant frequency of the pre-mode cleaner on the frequency of the light coming out of the PSL system. No obvious disadvantages were found in this configuration.

1. Introduction

The LIGO Pre-Stabilized Laser (PSL) system consists of a Laser, a reference cavity (RC) and its servo system, and a pre-mode cleaner (PMC) and its servo system. In the LIGO PSL system the light is picked off for the reference cavity before the pre-mode cleaner. The error signal obtained in the RC readout system is filter-amplified and fed back to the Laser. The error signal obtained in the PMC readout system is filter-amplified and fed back to the PMC.

Recently it was found at the 40m prototype at Caltech that the variation in the resonant frequency of the PMC caused by the vibration of the PMC was limiting the sensitivity in the frequency of the light coming out of the PSL. It was suggested by O. Miyakawa that an alternative configuration, that is, to pick off the light after the PMC, could reduce the noise. Actually C. Mow-Lowry has been preparing the change of the configuration at the 40m.

In this brief report these two configurations, picking off the light for the RC before and after the PMC, are compared in terms of the loop gain of the servo systems, the frequency stabilization, the effect of the variation in the resonant frequency of the cavities on the frequency of the light coming out of the PSL, and the effect of the noise in the cavity servo systems on the frequency of the light.

2. Block Diagram

Figure 1 shows the simplified schematic diagrams of the PSL system with the two configurations: the light picked off for the reference cavity (a) before the pre-mode cleaner and (b) after the pre-mode cleaner.

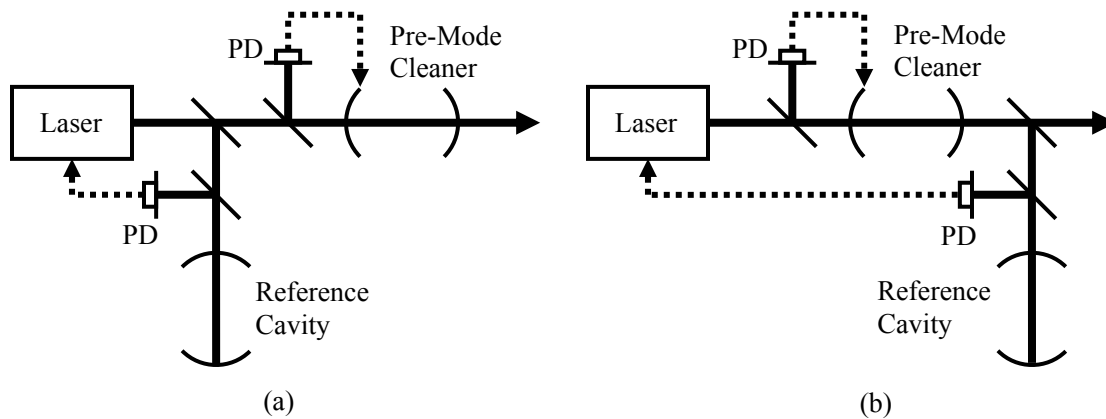

Fig. 1 Configurations of the pre-stabilized Laser with the light picked off for the reference cavity (a) before the pre-mode cleaner and (b) after the pre-mode cleaner.

The block diagrams of the systems with the two configurations are shown in Fig. 2. Here each symbol represents the following physical quantity:

ν_L : Frequency of the Laser

ν_{PMC} : Resonant frequency of the PMC determined by the cavity length of the PMC

ν_{RC} : Resonant frequency of the RC determined by the cavity length of the RC

ν_{out} : Frequency of the light coming out of the PSL

L_{PMC} : Low pass filter due to the cavity pole of the PMC

$$(L_{\text{PMC}} = \frac{\omega_{\text{PMC}}}{s + \omega_{\text{PMC}}}, s: \text{Laplace variable}, \omega_{\text{PMC}}: \text{cavity pole frequency of the PMC})$$

H_{PMC} : High pass filter due to the cavity pole of the PMC

$$(H_{\text{PMC}} = \frac{s}{s + \omega_{\text{PMC}}}, s: \text{Laplace variable}, \omega_{\text{PMC}}: \text{cavity pole frequency of the PMC})$$

L_{RC} : Low pass filter due to the cavity pole of the RC

$$(L_{\text{RC}} = \frac{\omega_{\text{RC}}}{s + \omega_{\text{RC}}}, s: \text{Laplace variable}, \omega_{\text{RC}}: \text{cavity pole frequency of the RC})$$

A_{PMC} : Gain of the sensor/filter/amplifier/actuator of the PMC servo in the configuration (a)

A_{RC} : Gain of the sensor/filter/amplifier/actuator of the RC servo in the configuration (a)

B_{PMC} : Gain of the sensor/filter/amplifier/actuator of the PMC servo in the configuration (b)

B_{RC} : Gain of the sensor/filter/amplifier/actuator of the RC servo in the configuration (b)

A triangle with + and – represents a discriminator. Note that L_{PMC} and H_{PMC} has the following relationship:

$$L_{\text{PMC}} + H_{\text{PMC}} = 1.$$

This relationship will be used very often in the following calculations.

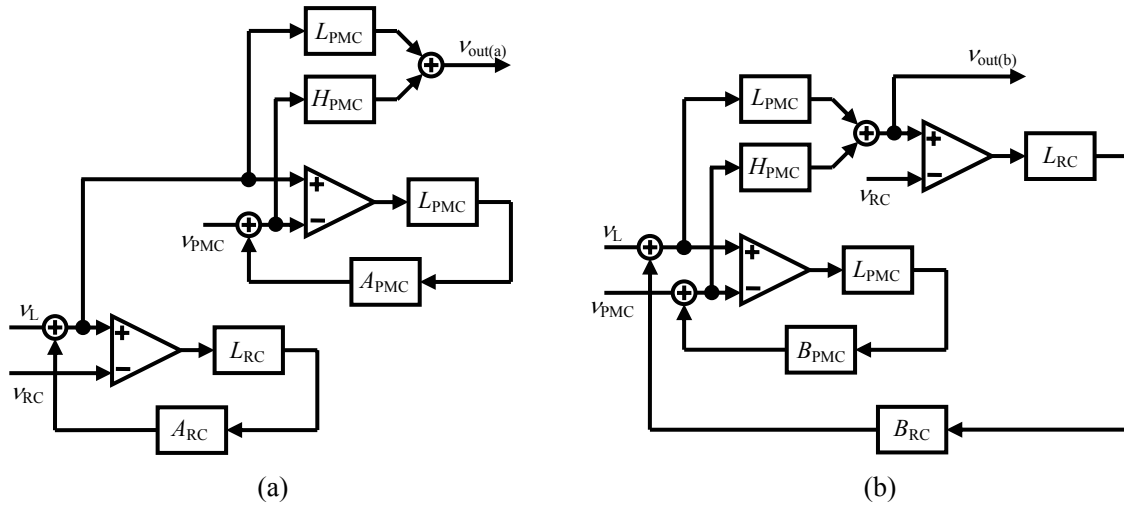

Fig. 2 Block diagrams of the pre-stabilized Laser with the light picked off for the reference cavity (a) before the pre-mode cleaner and (b) after the pre-mode cleaner.

3. Loop Gain

We will first compare the loop gains for both servos in the configuration (a) and (b).

The loop gains¹ of the RC servo and the PMC servo in the configuration (a), $G_{\text{RC(a)}}$, $G_{\text{PMC(a)}}$, are, respectively

$$G_{\text{RC(a)}} = L_{\text{RC}}A_{\text{RC}}$$

¹ In this report a loop gain of a servo system is defined to include “-1” as a negative feedback.

$$G_{\text{PMC(a)}} = -L_{\text{PMC}}A_{\text{PMC}}.$$

The loop gains of the RC servo and the PMC servo in the configuration (b), $G_{\text{RC(b)}}$, $G_{\text{PMC(b)}}$, are obtained by calculating the servo suppression ratio² for v_L and v_{PMC} , respectively.

$$G_{\text{RC(b)}} = \frac{L_{\text{RC}}B_{\text{RC}}L_{\text{PMC}}(1 + B_{\text{PMC}})}{1 + B_{\text{PMC}}L_{\text{PMC}}}$$

$$G_{\text{PMC(b)}} = \frac{B_{\text{PMC}}L_{\text{PMC}}(-1 + B_{\text{RC}}L_{\text{RC}})}{1 + B_{\text{RC}}L_{\text{PMC}}L_{\text{RC}}}$$

Note that the following plausible equations are not exactly correct:

$$G_{\text{RC(b)}} \neq L_{\text{RC}}B_{\text{RC}}L_{\text{PMC}}$$

$$G_{\text{PMC(b)}} \neq -L_{\text{PMC}}B_{\text{PMC}},$$

because of the combined servo loops existing in the configuration (b).

The LIGO PSL system for the 40m prototype has the configuration (a) with the following parameters:

Table 1 Parameters of the LIGO PSL

Reference Cavity Servo	Cavity Pole Frequency, ω_{RC}	40 kHz
	Unity Gain Frequency, $f_{\text{UG-RC}}$	500 kHz
Pre-Mode Cleaner Servo	Cavity Pole Frequency, ω_{PMC}	200 kHz
	Unity Gain Frequency, $f_{\text{UG-PMC}}$	1.6 kHz

In the following discussion, we assume that the system with the configuration (b) should also give the same performance as this system, namely:

$$f_{\text{UG-PMC}} \ll \omega_{\text{RC}} \ll \omega_{\text{PMC}} < f_{\text{UG-RC}}$$

Under this 40m PSL condition, we can easily prove that

$$G_{\text{RC(b)}} \approx L_{\text{RC}}B_{\text{RC}}L_{\text{PMC}}$$

$$G_{\text{PMC(b)}} \approx -L_{\text{PMC}}B_{\text{PMC}} \quad (f < f_{\text{UG-PMC}})$$

are correct³. Therefore in order to make the loop gain of both servos on the configuration (b) the same as those on the configuration (a) within the bandwidth of each servo system, we must satisfy the following conditions for B_{PMC} and B_{RC} :

$$B_{\text{RC}} = \frac{A_{\text{RC}}}{L_{\text{PMC}}}$$

$$B_{\text{PMC}} = A_{\text{PMC}}$$

We will call these equations “the conditions for equivalence”.

4. Frequency Stabilization

Here we will compare the frequency stabilization for the configuration (a) and (b).

The transfer function from v_L to $v_{\text{out(a)}}$ in the configuration (a) is

² In this report a servo suppression ratio is defined to be $1/(1-G_{\text{loop}})$, where G_{loop} is the loop gain of the servo system. Therefore the loop gain, G_{loop} , can be calculated from the servo suppression ratio.

³ Note that $L_{\text{PMC}}=1$ ($f < f_{\text{UG-PMC}}$).

$$\frac{v_{\text{out(a)}}}{v_L} = - \frac{(1 + A_{\text{PMC}})L_{\text{PMC}}}{(1 + A_{\text{PMC}}L_{\text{PMC}})(-1 + A_{\text{RC}}L_{\text{RC}})}$$

Under the 40m PSL condition, this can be approximated to

$$\frac{v_{\text{out(a)}}}{v_L} \approx - \frac{L_{\text{PMC}}}{(-1 + A_{\text{RC}}L_{\text{RC}})}$$

This indicates that the frequency of the light is stabilized by the loop gain of the RC servo, $G_{\text{RC(a)}} = L_{\text{RC}}A_{\text{RC}}$, and low-pass-filtered by the PMC, L_{PMC} .

The transfer function from v_L to $v_{\text{out(b)}}$ in the configuration (b) is

$$\frac{v_{\text{out(b)}}}{v_L} = - \frac{(1 + B_{\text{PMC}})L_{\text{PMC}}}{-1 - B_{\text{PMC}}L_{\text{PMC}} + (1 + B_{\text{PMC}})B_{\text{RC}}L_{\text{PMC}}L_{\text{RC}}}$$

Under the 40m PSL condition and also with the conditions for equivalence, this can be approximated to

$$\frac{v_{\text{out(b)}}}{v_L} \approx - \frac{L_{\text{PMC}}}{(-1 + A_{\text{RC}}L_{\text{RC}})}$$

This indicates that the frequency of the light is stabilized by the loop gain of the RC servo, $G_{\text{RC(a)}} = L_{\text{RC}}A_{\text{RC}}$, and low-pass-filtered by the PMC, L_{PMC} .

Therefore the frequency of the light is stabilized exactly in the same manner for the configuration (a) and (b).

5. Effect of the Resonant Frequency of the Cavities

We will compare the effect of the resonant frequency of the cavities for the configuration (a) and (b).

(1) v_{PMC}

The transfer function from v_{PMC} to $v_{\text{out(a)}}$ in the configuration (a) is

$$\frac{v_{\text{out(a)}}}{v_{\text{PMC}}} = \frac{H_{\text{PMC}}}{1 + A_{\text{PMC}}L_{\text{PMC}}}$$

This indicates that the effect of the resonant frequency of the PMC on v_{out} is suppressed by the loop gain, $G_{\text{PMC(a)}} = -L_{\text{PMC}}A_{\text{PMC}}$, and high-pass-filtered by the PMC, H_{PMC} .

The transfer function from v_{PMC} to $v_{\text{out(b)}}$ in the configuration (b) is

$$\frac{v_{\text{out(b)}}}{v_{\text{PMC}}} = - \frac{H_{\text{PMC}}}{-1 - B_{\text{PMC}}L_{\text{PMC}} + (1 + B_{\text{PMC}})B_{\text{RC}}L_{\text{PMC}}L_{\text{RC}}}$$

Under the 40m PSL condition and also with the conditions for equivalence, this can be approximated to

$$\frac{v_{\text{out(b)}}}{v_{\text{PMC}}} \approx \frac{H_{\text{PMC}}}{1 - A_{\text{RC}}L_{\text{RC}}(1 + A_{\text{PMC}})}$$

This indicates that the effect of the resonant frequency of the PMC on v_{out} is suppressed by the equivalent loop gain $A_{\text{RC}}L_{\text{RC}}(1 + A_{\text{PMC}})$ and high-pass-filtered by the PMC, H_{PMC} .

Therefore the configuration (b) gives more suppression to the effect of the resonant frequency of the PMC on v_{out} by the equivalent loop gain of $G_{\text{RC}} = A_{\text{RC}}L_{\text{RC}}$ than the configuration (a).

(2) v_{RC}

The transfer function from v_{RC} to $v_{\text{out(a)}}$ in the configuration (a) is

(1) N_{PMC}

The transfer function from N_{PMC} to $v_{\text{out(a)}}$ in the configuration (a) is

$$\frac{v_{\text{out(a)}}}{N_{\text{PMC}}} = \frac{A_{\text{PMC}}H_{\text{PMC}}}{1 + A_{\text{PMC}}L_{\text{PMC}}}$$

Under the 40m PSL condition, this can be approximated to

$$\frac{v_{\text{out(a)}}}{N_{\text{PMC}}} \approx \frac{A_{\text{PMC}}H_{\text{PMC}}}{1 + A_{\text{PMC}}}$$

This indicates that the effect of the noise of the PMC servo on $v_{\text{out(a)}}$ is high-pass-filtered by the PMC, H_{PMC} and decreases with A_{PMC} above the unity gain frequency of the PMC servo.

The transfer function from N_{PMC} to $v_{\text{out(b)}}$ in the configuration (b) is

$$\frac{v_{\text{out(b)}}}{N_{\text{PMC}}} = - \frac{B_{\text{PMC}}H_{\text{PMC}}}{-1 - B_{\text{PMC}}L_{\text{PMC}} + (1 + B_{\text{PMC}})B_{\text{RC}}L_{\text{PMC}}L_{\text{RC}}}$$

Under the 40m PSL condition and also with the conditions for equivalence, this can be approximated to

$$\frac{v_{\text{out(b)}}}{N_{\text{PMC}}} \approx \frac{A_{\text{PMC}}H_{\text{PMC}}}{(1 + A_{\text{PMC}})(1 - A_{\text{RC}}L_{\text{RC}})}$$

This indicates that the effect of the noise of the PMC servo on $v_{\text{out(a)}}$ is high-pass-filtered by the PMC, H_{PMC} , and suppressed by the loop gain $G_{\text{RC}}=A_{\text{RC}}L_{\text{RC}}$, and in addition decreases with A_{PMC} above the unity frequency of the PMC servo.

Therefore the configuration (b) gives more suppression to the effect of noise of the PMC on v_{out} by the loop gain of $G_{\text{RC}}=A_{\text{RC}}L_{\text{RC}}$ than the configuration (a).

(2) N_{RC}

The transfer function from N_{RC} to $v_{\text{out(a)}}$ in the configuration (a) is

$$\frac{v_{\text{out(a)}}}{N_{\text{RC}}} = - \frac{(1 + A_{\text{PMC}})A_{\text{RC}}L_{\text{PMC}}}{(1 + A_{\text{PMC}}L_{\text{PMC}})(-1 + A_{\text{RC}}L_{\text{RC}})}$$

Under the 40m PSL condition, this can be approximated to

$$\frac{v_{\text{out(a)}}}{N_{\text{RC}}} \approx \frac{A_{\text{RC}}L_{\text{PMC}}}{1 - A_{\text{RC}}L_{\text{RC}}}$$

This indicates that the effect of the Noise on the RC servo on v_{out} is low-pass-filtered by the PMC, L_{PMC} , and increases with $1/L_{\text{RC}}$ below the unity gain frequency of the RC servo, and decreases with A_{RC} above the unity gain frequency of the RC servo.

The transfer function from N_{RC} to $v_{\text{out(b)}}$ in the configuration (b) is

$$\frac{v_{\text{out(b)}}}{N_{\text{RC}}} = - \frac{(1 + B_{\text{PMC}})B_{\text{RC}}L_{\text{PMC}}}{-1 - B_{\text{PMC}}L_{\text{PMC}} + (1 + B_{\text{PMC}})B_{\text{RC}}L_{\text{PMC}}L_{\text{RC}}}$$

Under the 40m PSL condition and also with the conditions for equivalence, this can be approximated to

$$\frac{v_{\text{out(b)}}}{N_{\text{RC}}} \approx \frac{A_{\text{RC}}}{1 - A_{\text{RC}}L_{\text{RC}}}$$

This indicates that the effect of the Noise on the RC servo on v_{out} increases with $1/L_{\text{RC}}$ below the unity gain frequency of the RC servo, and decreases with A_{RC} above the unity gain frequency of the RC servo.

Therefore the configuration (a) gives more suppression by the low pass filter of the PMC, L_{PMC}

7. Summary

The results obtained by the above calculations are summarized in Table 2.

Table 2 Summary of the comparison of the various performances between configuration (a) and (b).

	Configuration (a)	Configuration (b)	Comments
Loop gain of PMC	$G_{\text{PMC(a)}} = -L_{\text{PMC}}A_{\text{PMC}}$	$G_{\text{PMC(b)}} \approx -L_{\text{PMC}}B_{\text{PMC}}$ ($f < f_{\text{UG-PMC}}$)	$B_{\text{PMC}} = A_{\text{PMC}}$ (conditions for equivalence)
Loop gain of RC	$G_{\text{RC(a)}} = L_{\text{RC}}A_{\text{RC}}$	$G_{\text{RC(b)}} \approx L_{\text{RC}}B_{\text{RC}}L_{\text{PMC}}$	$B_{\text{RC}} = \frac{A_{\text{RC}}}{L_{\text{PMC}}}$ (conditions for equivalence)
Frequency stabilization*	$\frac{v_{\text{out(a)}}}{v_{\text{L}}} \approx -\frac{L_{\text{PMC}}}{(-1 + A_{\text{RC}}L_{\text{RC}})}$	$\frac{v_{\text{out(b)}}}{v_{\text{L}}} \approx -\frac{L_{\text{PMC}}}{(-1 + A_{\text{RC}}L_{\text{RC}})}$	Same
Effect of resonant frequency of PMC*	$\frac{v_{\text{out(a)}}}{v_{\text{PMC}}} = \frac{H_{\text{PMC}}}{1 + A_{\text{PMC}}L_{\text{PMC}}}$	$\frac{v_{\text{out(b)}}}{v_{\text{PMC}}} \approx \frac{H_{\text{PMC}}}{1 - A_{\text{RC}}L_{\text{RC}}(1 + A_{\text{PMC}})}$	(b) better than (a) by $G_{\text{RC}} = A_{\text{RC}}L_{\text{RC}}$
Effect of resonant frequency of RC*	$\frac{v_{\text{out(a)}}}{v_{\text{RC}}} \approx \frac{L_{\text{PMC}}A_{\text{RC}}L_{\text{RC}}}{1 - A_{\text{RC}}L_{\text{RC}}}$	$\frac{v_{\text{out(b)}}}{v_{\text{RC}}} \approx \frac{A_{\text{RC}}L_{\text{RC}}}{1 - A_{\text{RC}}L_{\text{RC}}}$	(a) better than (b) by L_{PMC}
Effect of noise of PMC servo*	$\frac{v_{\text{out(a)}}}{N_{\text{PMC}}} \approx \frac{A_{\text{PMC}}H_{\text{PMC}}}{1 + A_{\text{PMC}}}$	$\frac{v_{\text{out(b)}}}{N_{\text{PMC}}} \approx \frac{A_{\text{PMC}}H_{\text{PMC}}}{(1 + A_{\text{PMC}})(1 - A_{\text{RC}}L_{\text{RC}})}$	(b) better than (a) by $G_{\text{RC}} = A_{\text{RC}}L_{\text{RC}}$
Effect of noise of RC servo*	$\frac{v_{\text{out(a)}}}{N_{\text{RC}}} \approx \frac{A_{\text{RC}}L_{\text{PMC}}}{1 - A_{\text{RC}}L_{\text{RC}}}$	$\frac{v_{\text{out(b)}}}{N_{\text{RC}}} \approx \frac{A_{\text{RC}}}{1 - A_{\text{RC}}L_{\text{RC}}}$	(a) better than (b) by L_{PMC}

40m PSL conditions are assumed.

* Conditions of equivalence are assumed.

The outstanding difference between the configuration (a) and (b) is the effect of the resonant frequency of PMC as expected. The configuration (b) gives significantly more suppression to the effect than the configuration (a). In addition the effect of the noise of the PMC servo is also better in the configuration (b) than (a) by $G_{\text{RC}} = A_{\text{RC}}L_{\text{RC}}$, although the effect of this noise might be negligible even with the configuration (a). All the advantages the configuration (a) has are only effective above the cavity pole frequency of the PMC; thus they are insignificant.

7. Conclusions

There are no significant disadvantages for the configuration (b). We should go ahead and change the configuration from (a) to (b).