



---

# PHOTON ACTUATION R&D PROGRAM

Michael Smith

8 Oct 02

# Current Status

---

- Preliminary concept- completed by Mike Zucker, 10/13/00
- Updated conceptual design- completed by Mike Smith, 10/1/02

# Photon Actuator Conceptual Design

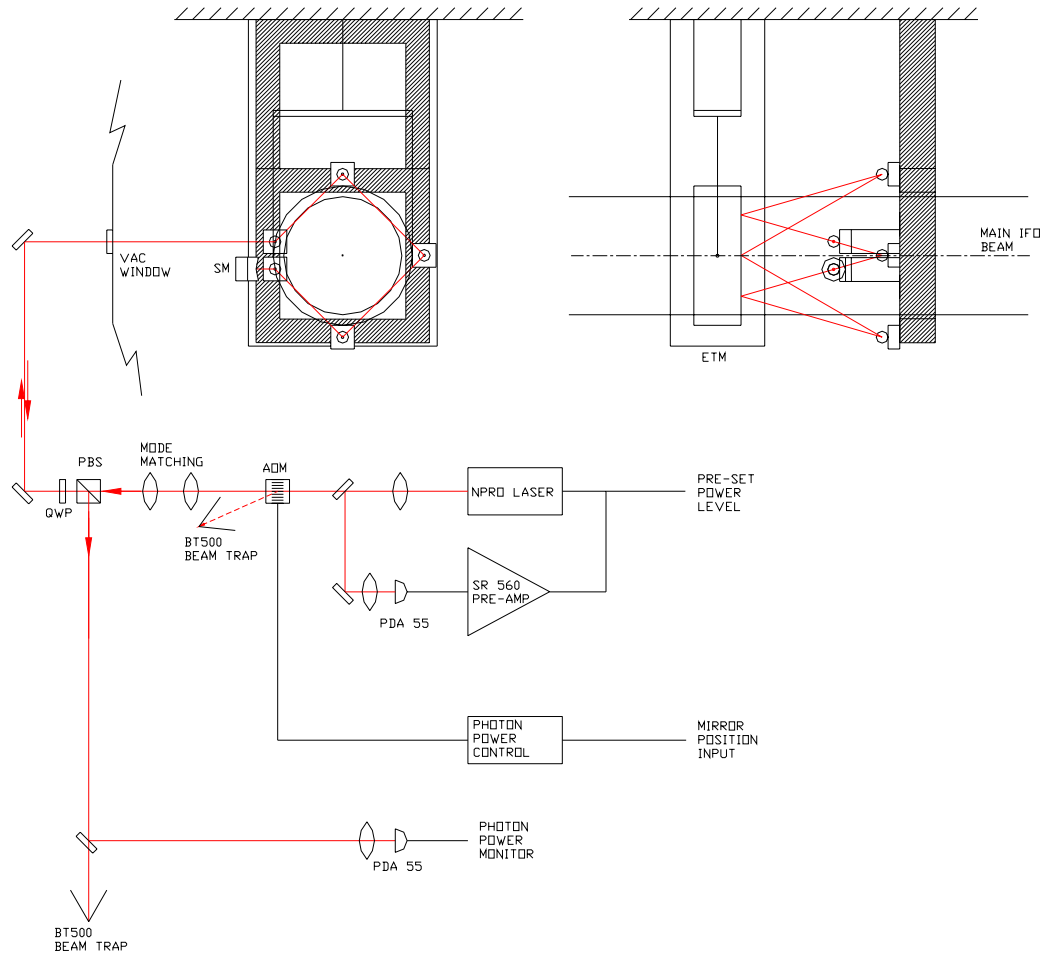

# Photon Actuator R&D Plans for 2003

---

- Finalize Design Requirements & Conceptual Design
- Preliminary design, Adv LIGO Photon actuator
- Simulink modeling, Adv LIGO photon actuator and quad pendulum suspension
- Design & build 40m breadboard photon actuator
  - Intensity stabilized NPRO
  - photon actuator opto-mechanical assembly
  - servo-controlled IFO mirror displacement
- IFO Mirror actuation experiment in 40m IFO

# Photon Actuator System Requirements

---

- Mirror actuation force<sup>1</sup>, RMS       $1 \times 10^{-11}$       N
- Mirror actuation force<sup>1</sup>, peak       $1 \times 10^{-10}$       N
- Actuator force noise spectrum<sup>1</sup>       $< 2.5 \times 10^{-15}$       N/Hz<sup>1/2</sup>
- Working frequency range<sup>1</sup>      10 – 10000      Hz

•1. Global Control Issues for Adv LIGO Quad Suspensions, G010086-00-D, Peter Fritschel, 3/16/01

# Photon Actuator Design Values

• Laser power	0.5	W
• Number of bounces	8	
• Photon force, RMS	$F_{\text{RMS}} = \frac{2NP}{\sqrt{2}c} = 1.9 \times 10^{-8}$	N
• Shot-noise-limited sampled laser power	$> 64 \times 10^{-6}$	W
• Photon force noise spectrum	$\tilde{F} \leq 2.5 \times 10^{-15}$	
• Laser power noise spectrum	$\tilde{P} \leq \frac{c}{2N} \tilde{F} = 4.7 \times 10^{-8}$	W/rtHz
• Relative intensity noise	$\frac{\tilde{P}}{P_{\text{RMS}}} \leq \frac{4.7 \times 10^{-8}}{0.5} \approx 10^{-7}$	1/rtHz

# NPRO

## Relative Intensity Noise

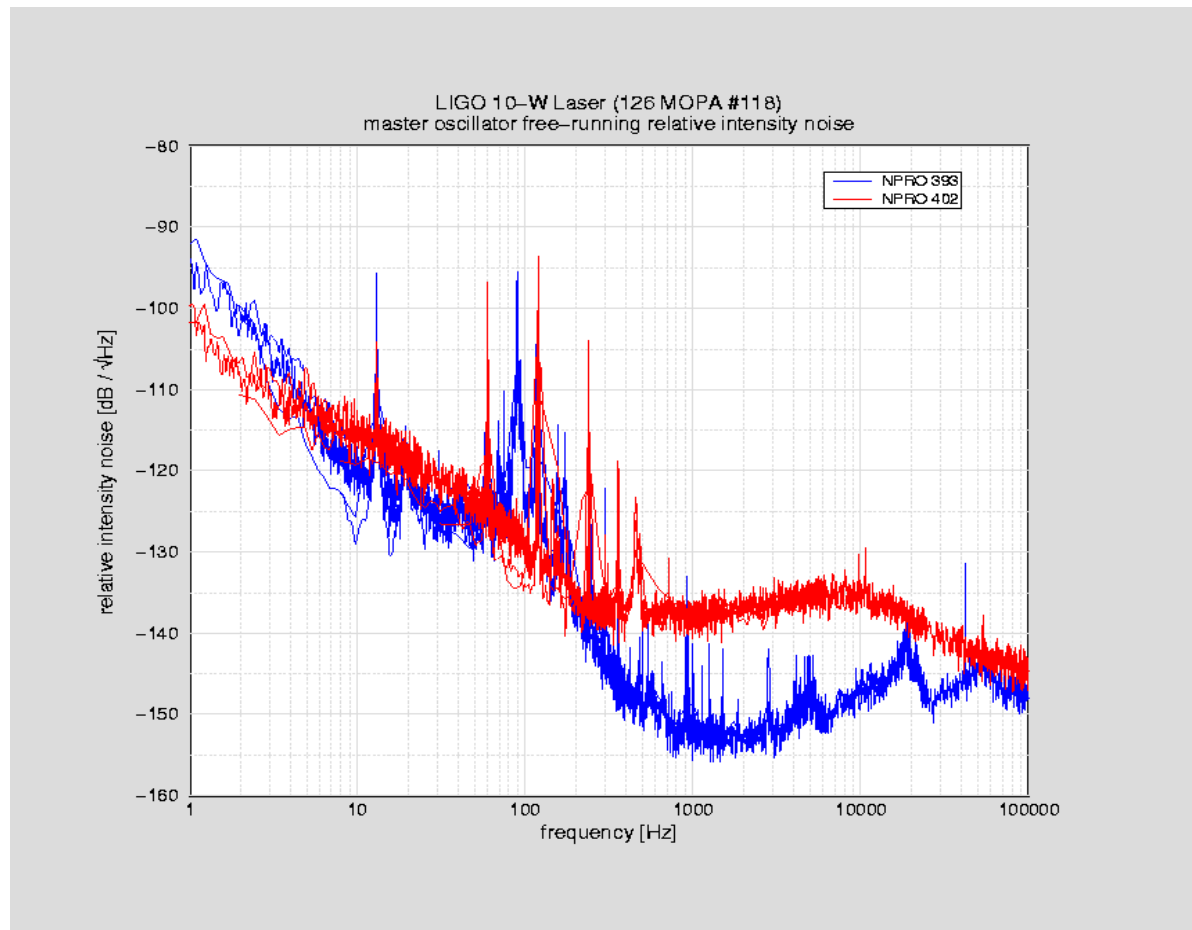

# Technical Risks and Opportunities

---

- The main technical risk is to achieve a relative intensity noise ratio (RIN) of  $<-140\text{DB}$  ( $10^{-7}$ ) with an intensity-stabilized NPRO laser, in the gravity wave band 10 Hz to 10000 Hz (according to Peter King, the risk is very low.)
- The breadboard experiment relies on the 40m IFO being operational and accessible during the summer 2003
- Good opportunity to use the 40m IFO for an additional Advanced LIGO R&D task

# Schedule Issues

---

- Jan – May 2003                      Design and Analysis
- June - Aug 2003                      Breadboard experiment
  
- Experiment conducted during the summer in order to utilize 2 SURF students
- 40m IFO should be operational during summer 2003

# Cost Baseline

---

● Fabricated parts	\$ 1000
● Purchased lab equipment (note 1)	<u>\$14000</u>
Total cost estimate	\$15000

note 1: assumes the loan of the following equipment:  
1ea NPRO laser

# Purchased Parts

---

● Fabricate photon actuation tower	\$ 1000
● Polarization beam splitter	580
● BS and mirrors (7)	1490
● Quarter wave plate	510
● Steering mirrors (5)	600
● PDA 55 (2)	1000
● Lens (5)	1000
● SR 560 (2)	5000
● Kinematic stage	415
● AOM & driver	1530
● Beam trap (2)	450
● Video camera	500
● Miscellaneous	1000

# Staffing Baseline and Issues

---

The following personnel, or equivalent, will be needed to complete the 2003 R&D program

● Michael Smith	480 hrs
● Mark Barton	240 hrs
● Electronic Engineer	132 hrs
● Osamu Miyakawa	320 hrs
● SURF student 1	400 hrs
● SURF student 2	<u>400 hrs</u>
total	1972 hrs

Note: Alan Weinstein also available