

-1 BELLOWS BRACKET
 1 REQ'D.
 MAT'L.: 6061-T6 ALUMINUM

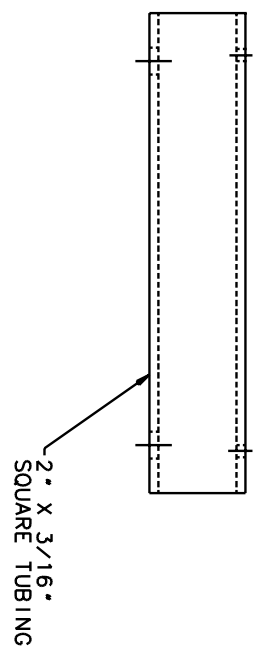
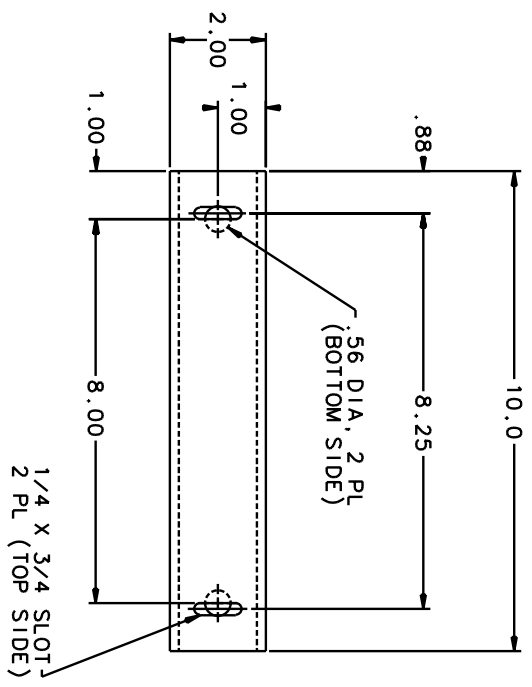

-2 STRAP BRACKET
 2 REQ'D.
 MAT'L.: 6061-T6 ALUMINUM

REMOVE ALL SHARP EDGES

TOLERANCES: X.XXX: +/- 0.005*
 X.XX: +/- 0.03*
 X.X: +/- 0.1*

DO10057-A
 TUBE SUPPORT BRACKETS
 40 M MODE CLEANER
 L. JONES
 5/3/01