



LIGO Laboratory / LIGO Scientific Collaboration

LIGO-T010120-00-D

ADVANCED LIGO

10/16/01

40m Auxiliary Optics Support System
Design Requirements Document & Conceptual Design

Michael Smith

Distribution of this document:
LIGO Science Collaboration

This is an internal working note
of the LIGO Project.

California Institute of Technology
LIGO Project – MS 18-34
1200 E. California Blvd.
Pasadena, CA 91125
Phone (626) 395-2129
Fax (626) 304-9834
E-mail: info@ligo.caltech.edu

Massachusetts Institute of Technology
LIGO Project – NW17-161
175 Albany St
Cambridge, MA 02139
Phone (617) 253-4824
Fax (617) 253-7014
E-mail: info@ligo.mit.edu

LIGO Hanford Observatory
P.O. Box 1970
Mail Stop S9-02
Richland, WA 99352
Phone 509-372-8106
Fax 509-372-8137

LIGO Livingston Observatory
P.O. Box 940
Livingston, LA 70754
Phone 225-686-3100
Fax 225-686-7189

<http://www.ligo.caltech.edu/>

Table of Contents

1	INTRODUCTION.....	7
1.1	PURPOSE.....	7
1.2	SCOPE.....	7
1.2.1	<i>Stray Light Control</i>	7
1.2.2	<i>Initial Alignment System (IAS)</i>	7
1.2.3	<i>Optical Lever System (OptLev)</i>	7
1.2.4	<i>Video Monitoring System</i>	7
1.3	DEFINITIONS.....	7
1.4	ACRONYMS.....	8
1.5	APPLICABLE DOCUMENTS.....	9
1.5.1	<i>LIGO Documents</i>	9
1.5.2	<i>Non-LIGO Documents</i>	10
2	GENERAL DESCRIPTION.....	11
2.1	PRODUCT PERSPECTIVE.....	11
2.1.1	<i>Stray Light Control</i>	13
2.1.1.1	Wedge Angles.....	13
2.1.1.2	Beam Dumps and Baffles.....	13
2.1.1.3	Attenuators.....	14
2.1.2	<i>Initial Alignment System</i>	14
2.1.3	<i>Optical Lever System</i>	14
2.2	PRODUCT FUNCTIONS.....	14
2.2.1	<i>Stray Light Control</i>	14
2.2.2	<i>Initial Alignment System</i>	15
2.2.3	<i>Optical Lever System</i>	15
2.2.4	<i>Video Monitoring System</i>	15
2.3	GENERAL CONSTRAINTS.....	15
2.3.1	<i>Core Optics Parameters</i>	15
2.3.2	<i>Interferometer Design Parameters</i>	16
2.3.3	<i>Seismic Environment</i>	16
3	REQUIREMENTS.....	17
3.1	STRAY LIGHT CONTROL REQUIREMENTS.....	17
3.1.1	<i>Introduction</i>	17
3.1.2	<i>Stray Light Control Characteristics</i>	18
3.1.2.1	Stray Light Control Performance Characteristics.....	18
3.1.2.2	Stray Light Control Physical Characteristics.....	23
3.1.2.3	Stray Light Control Interface Definitions.....	23
3.1.2.4	Stray Light Control Reliability.....	23
3.1.2.5	Stray Light Control Maintainability.....	23
3.1.3	<i>Stray Light Control Precedence</i>	23
3.1.4	<i>Stray Light Control Qualification</i>	24
3.2	INITIAL ALIGNMENT SYSTEM REQUIREMENTS.....	24
3.2.1	<i>Introduction</i>	24
3.2.2	<i>Initial Alignment System Characteristics</i>	24
3.2.2.1	Initial Alignment System Performance Characteristics.....	24
3.2.2.2	Initial Alignment System Physical Characteristics.....	24
3.2.2.3	Initial Alignment System Interface Definitions.....	26
3.2.2.4	Initial Alignment System Reliability.....	26
3.2.2.5	Initial Alignment System Maintainability.....	26
3.2.3	<i>Initial Alignment System Assembly and Maintenance</i>	27
3.2.4	<i>Initial Alignment System Precedence</i>	27
3.2.5	<i>Initial Alignment System Qualification</i>	27
3.3	OPTICAL LEVER SYSTEM REQUIREMENTS.....	27

3.3.1	<i>Optical Lever System Characteristics</i>	27
3.3.1.1	Optical Lever System Performance Characteristics	31
3.3.1.2	Optical Lever System Physical Characteristics	32
3.3.1.3	Optical Lever System Interface Definitions	33
3.3.1.4	Optical Lever System Reliability	33
3.3.1.5	Optical Lever System Maintainability	33
3.3.2	<i>Optical Lever System Assembly and Maintenance</i>	34
3.3.3	<i>Optical Lever System Precedence</i>	34
3.3.4	<i>Optical Lever System Qualification</i>	34
3.4	VIDEO MONITOR SYSTEM REQUIREMENTS.....	34
3.4.1	<i>Video Monitor System Characteristics</i>	34
3.4.1.1	Video Monitor System Performance Characteristics	36
3.4.1.2	Video Monitor System Physical Characteristics	37
3.4.1.3	Video Monitor System Interface Definitions	37
3.4.1.4	Video Monitor System Reliability	37
3.4.1.5	Video Monitor System Maintainability.....	37
3.4.2	<i>Video Monitor System Assembly and Maintenance</i>	38
3.4.3	<i>Video Monitor System Precedence</i>	38
3.4.4	<i>Video Monitor System Qualification</i>	38
4	GENERAL REQUIREMENTS	39
4.1	ENVIRONMENTAL CONDITIONS	39
4.2	TRANSPORTABILITY.....	39
4.3	DESIGN AND CONSTRUCTION.....	39
4.3.1	<i>Materials and Processes</i>	39
4.3.1.1	Finishes	39
4.3.1.2	Materials	39
4.3.1.3	Processes	40
4.3.1.4	Component Naming	40
4.3.2	<i>Workmanship</i>	40
4.3.3	<i>Safety</i>	40
4.3.4	<i>Human Engineering</i>	40
4.4	ASSEMBLY AND MAINTENANCE.....	40
4.5	DOCUMENTATION.....	41
4.5.1	<i>Specifications</i>	41
4.5.2	<i>Design Documents</i>	41
4.5.3	<i>Engineering Drawings and Associated Lists</i>	41
4.5.4	<i>Technical Manuals and Procedures</i>	41
4.5.4.1	Procedures	41
4.5.4.2	Manuals	42
4.5.5	<i>Documentation Numbering</i>	42
4.5.6	<i>Test Plans and Procedures</i>	42
4.6	LOGISTICS	42
5	QUALITY ASSURANCE PROVISIONS	43
5.1	GENERAL.....	43
5.1.1	<i>Responsibility for Tests</i>	43
5.1.2	<i>Special Tests</i>	43
5.1.2.1	Engineering Tests.....	43
5.1.2.2	Reliability Testing.....	43
5.1.3	<i>Configuration Management</i>	43
5.2	QUALITY CONFORMANCE INSPECTIONS.....	43
5.2.1	<i>Inspections</i>	43
5.2.2	<i>Analysis</i>	44
5.2.3	<i>Demonstration</i>	44
5.2.4	<i>Similarity</i>	44
5.2.5	<i>Test</i>	44

6	PREPARATION FOR DELIVERY	45
6.1	PREPARATION.....	45
6.2	PACKAGING.....	45
6.3	MARKING.....	45
7	NOTES	46
7.1	SCATTERED LIGHT NOISE THEORY.....	46
7.1.1	Noise Allocation Factor.....	47
7.1.1.1	K_{RC} Recycling Cavity.....	47
7.1.1.2	K_{Arm} Arm Cavity	47
7.1.1.3	K_{SPS} Symmetric Port Signal, and K_{ETM} End Test Mass Transmitted Beam	48
7.1.1.4	K Values	48
7.1.2	Principal Scattering Sources.....	49
7.1.3	APS Photodetector.....	49
7.1.4	Beam Glint	49

Table of Tables

<i>Table 1: Core Optics Parameters</i>	<i>15</i>
<i>Table 2: Interferometer Design Parameters.....</i>	<i>16</i>
<i>Table 3: Scattered Light Requirements.....</i>	<i>21</i>
<i>Table 4: SEI-mounted Beam Dump Optical Requirements</i>	<i>21</i>
<i>Table 5: Arm Cavity Baffle Optical Requirements</i>	<i>22</i>
<i>Table 6: Mode Cleaner Baffle Optical Requirements.....</i>	<i>22</i>
<i>Table 7: Cavity Beam Dump Mechanical Resonance Requirements.....</i>	<i>22</i>
<i>Table 8: Angle sensitivity, zoom optical lever sensor</i>	<i>32</i>
<i>Table 9: Optical lever system physical characteristics</i>	<i>33</i>
<i>Table 10: Video Monitor System Performance Characteristics</i>	<i>37</i>
<i>Table 11: Video Monitor system physical characteristics</i>	<i>37</i>
<i>Table 12: Parameters for the K values.....</i>	<i>48</i>
<i>Table 13 : K values, seismic surfaces</i>	<i>49</i>
<i>Table 14: Glint efficiency.....</i>	<i>50</i>

Table of Figures

Figure 1: 40 m IFO vertex section.....	11
Figure 2: 40 m IFO mode cleaner section.....	12
<i>Figure 3: 40 m IFO end section.....</i>	<i>13</i>
<i>Figure 4: RM, ITM, and ETM ghost beam naming convention.....</i>	<i>18</i>
<i>Figure 5: BS ghost beam naming convention.....</i>	<i>19</i>
Figure 6: Optical lever, ETMx	28
<i>Figure 7: Optical lever, ITMx.....</i>	<i>29</i>
<i>Figure 8: Optical lever, ITMy.....</i>	<i>30</i>
<i>Figure 9: Optical lever, PRM, BS, SRM.....</i>	<i>31</i>
<i>Figure 10: Optical lever projector.....</i>	<i>32</i>
<i>Figure 11: Video monitor for IMC flat mirrors</i>	<i>35</i>

Figure 12: Video monitor for ITMy 35
Figure 13: Video monitor for PRM, BS, SRM 36
Figure 14: Video monitor for ETMx..... 36

1 Introduction

1.1 Purpose

The purpose of this document is to describe the design requirements for the Auxiliary Optics Support (AOS). Primary requirements are derived (“flowed-down”) from the Conceptual Design of the 40 Meter Laboratory Upgrade for Prototyping an Advanced LIGO Interferometer, LIGO-T010029.

1.2 Scope

The AOS system is comprised of four distinct subsystems: Stray Light Control (SLC), Initial Alignment System (IAS), Optical Lever System (OptLev), and Video Monitoring System.

1.2.1 Stray Light Control

The Stray Light Control subsystem consists of 1) beam dumps to block the principal ghost beams (reflections from anti-reflection coatings and optic wedges) produced by COC and reflections from viewport windows, 2) arm cavity baffles to block the scattered light from the cavity mirrors, 3) baffling around the Input Mode Cleaner and between the output of the IO Mode Matching telescope and the input to the recycling cavity.

It will not provide baffling for the PSL optical train.

1.2.2 Initial Alignment System (IAS)

The Initial Alignment subsystem consists of 1) precision optical surveying equipment for measuring angular orientations, and locations of the COC mirrors, 2) surveyed reference monuments for absolute positioning of the surveying equipment, and 3) a procedure for positioning and aligning the COC mirrors.

1.2.3 Optical Lever System (OptLev)

The Optical Lever subsystem consists of 1) laser transmitter, 2) optical steering mirrors inside and outside the vacuum chambers, and 3) zoom optical receiver for angle sensing.

1.2.4 Video Monitoring System

The Video Monitoring System consists of video cameras placed outside a camera viewport on the vacuum chambers with steering mirrors inside to direct the view to the HR side of the COC mirrors.

1.3 Definitions

TBD

Define all terms used in the document as necessary to interpret its contents. For example, a CDS specification may make use of terminology, such as “real-time software”, which is subject to interpretation. This section should specifically define what “real-time software” means in the context of this document.

NOTE: This should include all standard names used in interface discussions/drawings.

1.4 Acronyms

LIGO - Laser Interferometer Gravity Wave Observatory

COS - Core Optics Support

IOO - Input Optics

DRD - Design Requirements Document

PRM – Power Recycling Mirror

SRM- Signal Recycling Mirror

BS - Beam Splitter

ITM_x, ITM_y - Input Test Mass in the interferometer ‘X’ or ‘Y’ arm

ETM_x, ETM_y - End Test Mass in the interferometer ‘X’ or ‘Y’ arm

AR - Antireflection Coating

HR - Reflective mirror coating

GBAR - Ghost Beam from AR side of COC

GBHR - Ghost Beam from HR side of COC

PO - Pick-off

vh - Vacuum housing

SEI - Seismic Isolation subsystem

SUS - Suspension subsystem

ppm - parts per million

ISC- Interferometer Sensing and Control

LSC - Length Sensing and Control

COC - Core Optics Components

ASC - Alignment Sensing and Control

IFO - LIGO interferometer

BSC - Beam Splitter Chamber

BRDF - Bi-directional Reflectance Distribution Function

SLC- Stray Light

OMC- Output Mode

IAS- Initial Alignment

OptLev- Optical Lever

IPB- Initial Pointing Beam

TBD - To Be Determined

AP1 - antisymmetric port signal, transmitted through the Signal mirror

AP2 - antisymmetric port signal, transmitted through the output mode cleaner

SPS - symmetric port signal

rms - root-mean-square

p-v, peak to valley

1.5 Applicable Documents

List all documents referenced. Include only those expressly mentioned within this document.

1.5.1 LIGO Documents

Conceptual Design of the 40 Meter Laboratory Upgrade for Prototyping an Advanced LIGO Interferometer, LIGO T010115

Effect of PO Telescope Aberrations on Wavefront Sensor Performance, LIGO-T980007-00-D

LIGO Vacuum Compatibility, Cleaning Methods and Procedures, LIGO-E960022-00-D

LIGO-E000007-00

LIGO Naming Convention (LIGO-E950111-A-E)

LIGO Project System Safety Management Plan LIGO-M950046-F

LIGO EMI Control Plan and Procedures (LIGO-E960036)

Specification Guidance for Seismic Component Cleaning, Baking, and Shipping Preparation (LIGO-L970061-00-D)

LIGO-E000408, ITM

E000410, specification ETM

E000413, specification BS

E000409, specification RM

D970535, specification MC flat

D970534, specification MC curved

Core Optics Support Design Requirements Document LIGO-T970071-03-D

COS Beam Dump and Stray Light Baffle Revised Req. and Concepts LIGO-T980103-00-D

Up-conversion of Scattered Light Phase Noise from Large Amplitude Motions, LIGO-T980101-00D

1.5.2 Non-LIGO Documents

2 General description

2.1 Product Perspective

The relationships between the various subsystems and the entire IFO optical system can be seen in the following layout drawings.

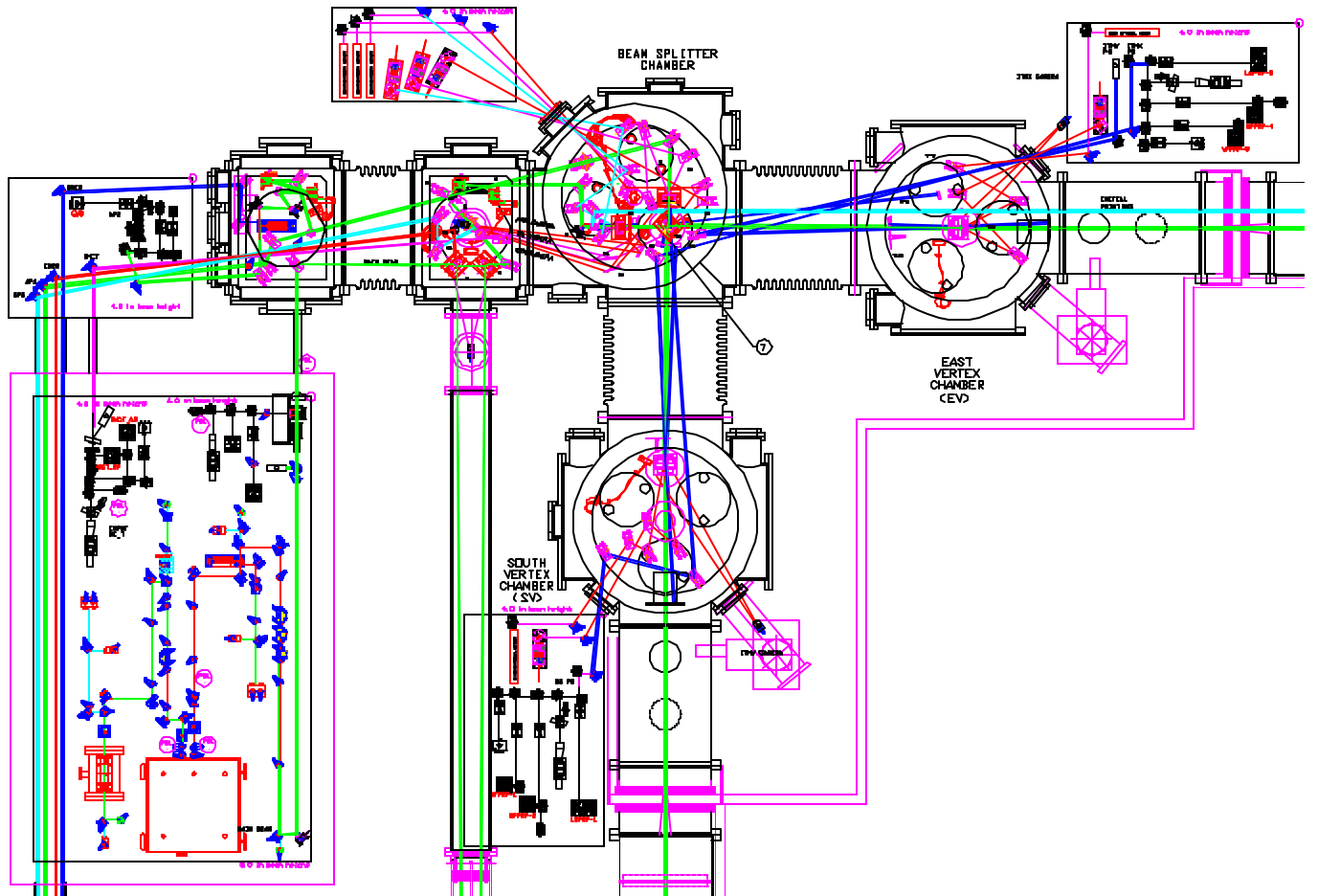

Figure 1: 40 m IFO vertex section

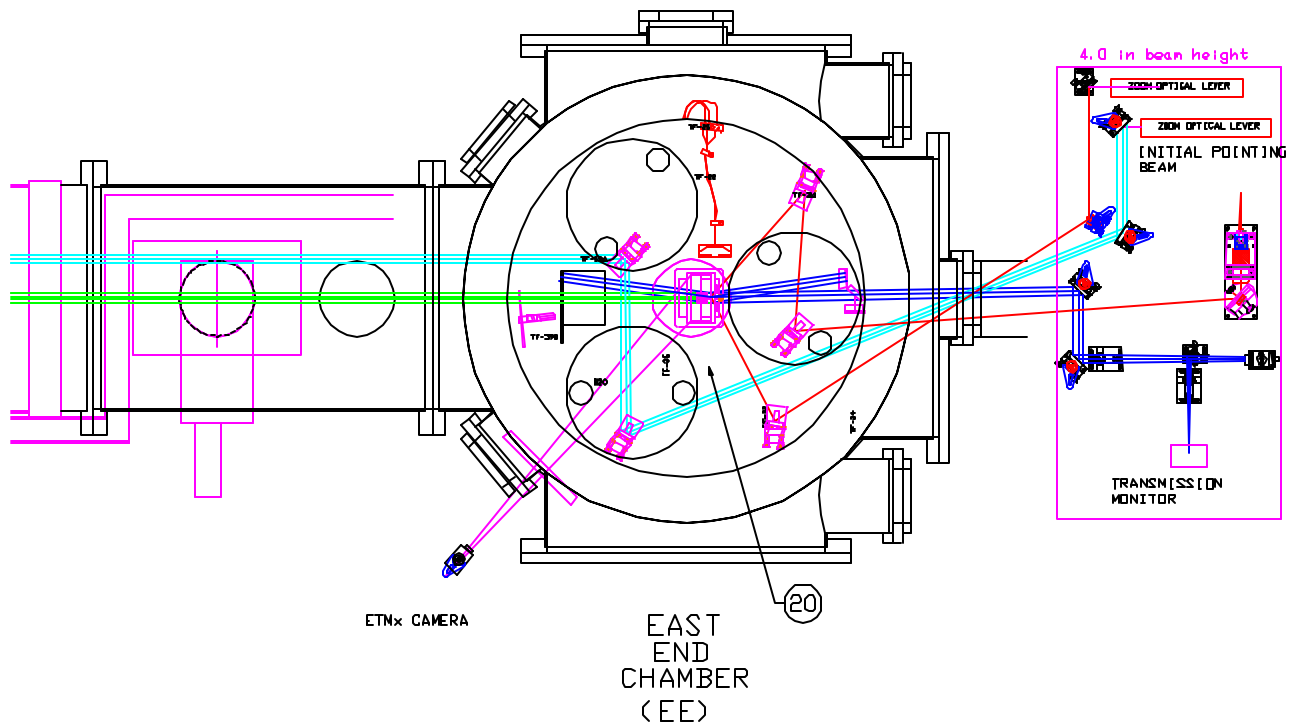

Figure 3: 40 m IFO end section

2.1.1 Stray Light Control

2.1.1.1 Wedge Angles

The Stray Light Control subsystem will set minimum wedge angle requirements for the substrates of the power recycling mirror (RM), the beam splitter (BS), the signal recycling mirror (SM), the input test mass mirrors (ITM_x and ITM_y), and the end test mass mirrors (ETM_x and ETM_y). The minimum wedge angles guarantee that the ghost beams will separate sufficiently from the main beam to enable the placement of beam dumps and PO mirrors.

2.1.1.2 Beam Dumps and Baffles

The Stray Light Control subsystem will reduce the power of the scattered ghost beams from the COC to acceptable levels. Baffles will be mounted inside the arm cavity to reduce the scattering of diffuse scattered light from the COC into the interferometer main beam. Baffles will be placed inside the input chamber to restrict the passage of scattered light from the Input Optics system into the recycling cavity.

2.1.1.3 Attenuators

Attenuators and Faraday isolators will be mounted on optical tables inside the vacuum chambers in the PO and AP optical paths to reduce the scattered light from the LSC and ASC photodetectors that re-enters the interferometer main beam.

2.1.2 Initial Alignment System

The Initial Alignment subsystem consists of 1) precision optical surveying equipment for measuring angular orientations, and locations of the COC mirrors, 2) surveyed reference monuments for absolute positioning of the surveying equipment, and 3) a procedure for positioning and aligning the COC mirrors.

2.1.3 Optical Lever System

Individual optical lever beam transmitters will be positioned on tables T-OL, T-SV, T-EV, T-SE, and T-EE outside the vacuum chambers. The optical lever beams will pass through viewports and be directed by steering mirrors on the optical tables in the BS, SV, EV, SE, and EE chambers to reflect from the face of each suspended COC optic- BS, RM, SM, ITM_x, ITM_y, ETM_x, ETM_y. The reflected beams will, in turn, be directed by steering mirrors out through the respective viewport and into individual zoom optical receivers, which will monitor continually the angular orientation of the COCs. The angular sensitivity of the zoom optical levers can be varied remotely by means of an electronically controlled zoom focus lens.

2.2 Product Functions

2.2.1 Stray Light Control

- 1) COC Beam dumps- Beam dumps will reduce the scattered light phase noise from the following sources: ghost beams that originate from the wedged AR surfaces of the core optics mirrors and the reflection of pick-off beams from the surfaces of PO viewports.
- 2) Arm Cavity Baffle will reduce the scattered light phase noise caused by the small-angle diffuse scattering from the test mass mirrors in the arm cavity.
- 3) Input Mode Cleaner Baffles will control the scattered light from the Input Mode Cleaner mirrors.
- 4) IO Baffle will reduce the passage of scattered light from the input (IOO) optics region into the recycling cavity region.
- 5) Attenuators in the PO beam bath will reduce the scattered light phase noise from the PO beam photodetectors.
- 6) Faraday isolator in the AP beam path will reduce the scattered light phase noise from the AP1 and AP2 photodetectors.

2.2.2 Initial Alignment System

The Initial Alignment subsystem will provide a means for positioning the suspended core optics in global coordinates and provide angular alignment to within 10% of the core optics adjustment range. This will allow the operator to use the CDS control system to position the beam back upon itself and to switch to the ASC Alignment Sensing and Control system.

Initial Alignment will be similar to the LIGO-1.

2.2.3 Optical Lever System

The Optical Levers provide two primary functions. They provide a means of monitoring the optic orientation for long-term drift due to the suspensions or seismic isolation system. They also provide maintenance and setup functions such as diagonalization of the core optic, core optic replacement, and realignment caused by catastrophic events (i.e. Earthquakes). They are not intended as feedback devices to the ASC Alignment Sensing and Control subsystem.

The optical lever sensor will incorporate a variable optical gain, which will enable the optical lever to function either as a local or as a global optical lever.

2.2.4 Video Monitoring System

Video cameras will provide a view of each COC mirror HR surface so that the position of the 1064 nm spot on the mirror can be determined, as well as an indication of the mode shape of the laser spot.

2.3 General Constraints

The Auxiliary Optics Support System design is constrained by the requirements of the Conceptual Design of the 40 Meter Laboratory Upgrade for Prototyping an Advanced LIGO Interferometer, LIGO T010115.

The assumptions and dependencies that affect the design are listed in the following section.

2.3.1 Core Optics Parameters

See Core Optics Specifications: LIGO-E000408, ITM; E000410, ETM; E000413, BS; E000409, RM; D970535, MC flat; D970534, MC curved

Table 1: Core Optics Parameters

Physical Quantity	PRM	SRM	BS	ITM	ETM
AR coating @ 1060 nm	<0.0005	<0.0005	0.0006	0.0006	<0.0005
AR coating @ 940 nm	>0.4	>0.4	>0.4	>0.4	NA
Substrate thickness, mm	28	28	28	50	50
Mirror power loss fraction	<0.00004	<0.00004	<0.00004	<0.00004	<0.00004
Mirror reflectivity @ 1060 nm	0.93	0.93	0.5	0.995	0.9999625

Mirror reflectivity @ 940 nm	>0.4	>0.4	>0.4	>0.4	>0.4
Mirror reflectivity @ 670 nm	>0.04	>0.04	>0.04	>0.04	>0.04
Refractive index @ 1064 nm	1.44963	1.44963	1.44963	1.44963	1.44963
Beam waist, mm	3.04	3.04	3.03	3.03	5.24
1ppm power contour radius, mm	7.97	7.98	7.97	7.96	13.8
Mirror diameter, mm	75	75	75	125	125
Mirror thickness, mm	25	25	25	50	50

2.3.2 Interferometer Design Parameters

The stray light calculations were based on the following assumed parameters:

Table 2: Interferometer Design Parameters

Laser input power	6 W
SPS power	0.06 W
AP1 power	0.03 W
AP2 power	0.03 W
IFO Gaussian beam radius, w	3.03 mm
Recycling cavity gain	14
Arm cavity gain	767

2.3.3 Seismic Environment

The scattered light noise calculations in this document are based on the assumption that the rms velocity of scattering surfaces is sufficiently low so that up-conversion of large amplitude low frequency motion does not produce in-band phase noise. This is true for the vacuum housing and is also true of the SEI platforms for stack Q's less than 1000. See Seismic Isolation DRD, LIGO-T960065-02-D, and Locally Damped Test Mass Motion, LIGO-T970092-00-D.

The ground noise spectrum for the scattered light noise calculations was taken from figure 15, LIGO-T010115. In the frequency range 10 Hz to 100 Hz, the ground displacement spectrum can be approximated by the following analytical expression:

$$x = 3.63 \times 10^{-8} f^{1.65}.$$

3 Requirements

3.1 Stray Light Control Requirements

3.1.1 Introduction

The scattered light phase noise shall not exceed 1/10 the total fundamental strain noise of the 40m IFO, as shown in figure 14 of LIGO-T010115.

Light scattered from baffles and other optical elements whose rays lie within the Rayleigh solid angle of the interferometer cavity will cause phase noise on the output signal. The amplitude of the phase noise is proportional to the rms amplitude of the horizontal motion of the scattering surface and to the rms electric field amplitude of the scattered light injected into the IFO. This assumes surface motions small compared to a wavelength of the light, which is a valid assumption for resonant surfaces with Q s less than 1000.

The scattered light requirements are based upon the following assumptions: 1) the transfer function for the conversion of scattered light power to interferometer phase noise obeys the same functional dependence as LIGO 1, 2) the ISC output photodetectors are coupled directly to the ground motion.

Two categories of scattered light, in decreasing order of amplitude, are considered: 1) scattering from windows and other optical elements, such as photodetectors, that are connected to the seismic ground motion, 2) scattering from beam-dumps and baffles mounted on SEI optical platforms.

The most significant scattered light noise sources are the following: 1) The AP1 output beam that back-scatters from the surface of the external photodetector, 2) The AP2 output beam that back-scatters from the surface of the external photodetector, 3) the two ETM transmission beams that back-scatter from the surface of the output viewports, 4) the two ETM transmission beams that back-scatter from the surface of the transmission monitors, 5) the glint from the AP1 lens in the output chamber back into the IFO. These scattered light noise sources account for over 98% of the scattered light noise.

As a precaution, the first-order ghost beams from the COC mirrors will be captured with beam dumps to avoid a glint from the inside of the chamber walls. Light scattered from the SEI mounted beam dump can be neglected.

In general, the light back-scattered from an external surface into the solid angle of the IFO is proportional to the following factors: 1) the light power incident on the scattering surface, 2) a transmission factor that accounts for the return-trip transmissivity through the COC element which produced the incident beam, 3) the cosine of the incident angle at the scattering surface, 4) the BRDF of the surface, 5) the solid angle of the IFO beam, 6) the added attenuation factor (if any) of the return path, and (7) inversely proportional to the square of the de-magnification factor (ratio of scattering beam area to IFO mode area).

The de-magnification factor must be included whenever scattering occurs from an incident beam whose diameter has been de-magnified from the original IFO diameter by the AOS telescope or by

other focusing elements in the ISC detection system. An increase in acceptance solid angle results from a decrease in beam diameter because the product of solid angle and beam area is proportional to the total radiant flux, which is an optical invariant; therefore, as the beam area decreases the solid angle increases proportionally. The acceptance solid angle for the scattered light is inversely proportional to the square of the de-magnification factor.

3.1.2 Stray Light Control Characteristics

3.1.2.1 Stray Light Control Performance Characteristics

3.1.2.1.1 Baffles and Beam Dumps

Descriptions of the ghost beam naming conventions for the COC mirrors and the beam splitter are shown in the following figures.

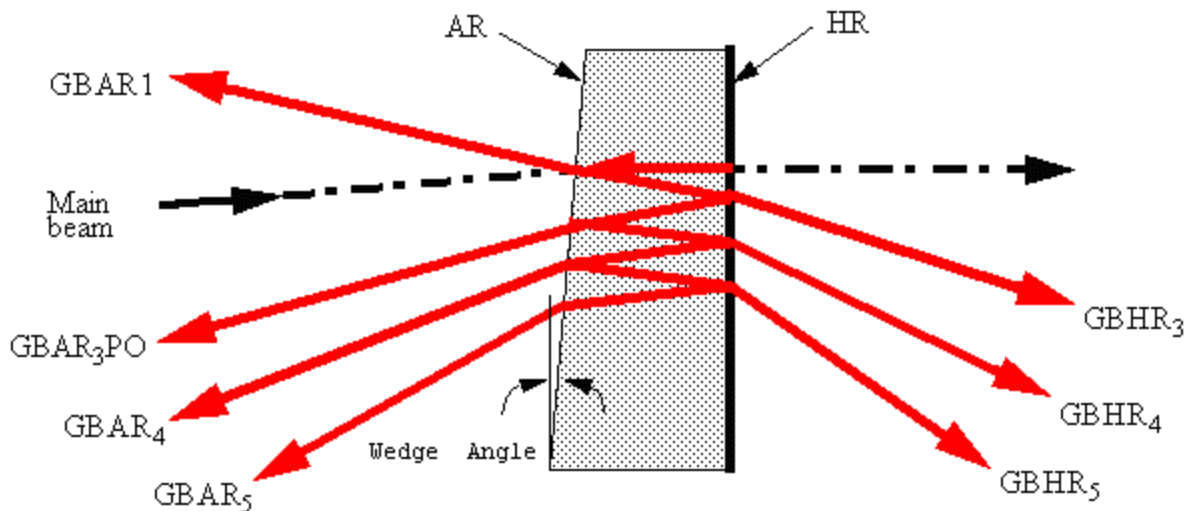

Figure 4: RM, ITM, and ETM ghost beam naming convention

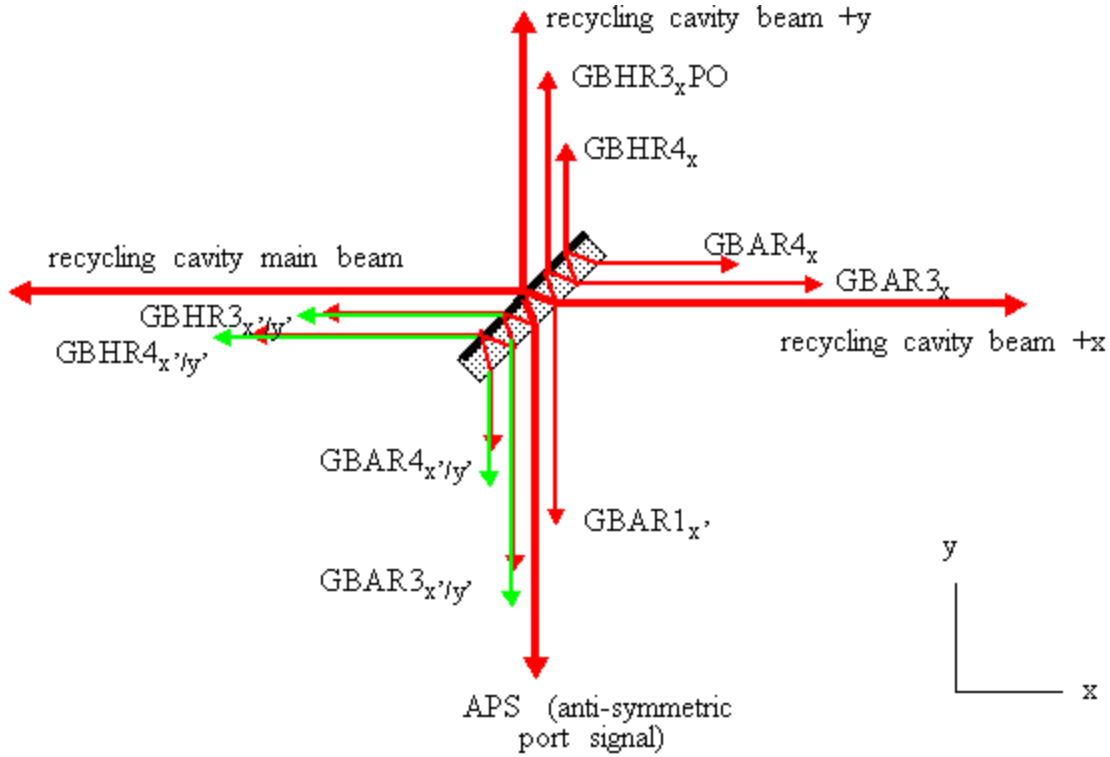

Figure 5: BS ghost beam naming convention

The light scattered into the interferometer from each source was calculated from the following equation:

$$P_s = P_i \cdot T \cdot [\cos \theta_{iwo} \cdot BRDF_{wo}(\theta_i)] \cdot \Delta \Omega \cdot \frac{1}{M^2} \cdot A_i$$

Where P_i is the incident power, T is the transmissivity into the IFO from the scattering source, M is the beam de-magnification ratio, A_i is an additional attenuation factor of the scattered light as it re-enters the IFO.

The scattered light requirements were calculated from the following equation:

$$\left(\frac{P_{si}}{P_0} \right)_{REQ} \leq \frac{F_i}{N_i \cdot K_i^2} \cdot \left(\frac{1}{10} \right)^2$$

Where P_0 is the laser power into the recycling cavity, F_i is the noise allocation factor, K_i is the amplitude noise strength parameter, and N_i is the number of identical sources.

The noise allocation factors F_i were assigned by modeling all of the anticipated scattering sources and paths (See Core Optics Support Design Requirements Document, LIGO-T970071-03-D), and

by allocating the total noise budget in proportion to the scattered light of the principal sources. The noise allocation factors are discussed in the appendix 7.1.1.

The following parameters were assumed.

Input laser power, $P_0 = 6 \text{ w}$

recycling cavity gain, $G_{rc} = 14$

BRDF of photodetector surface = 0.0008

BRDF of viewport surface = 0.03

Solid angle of interferometer beam = $3.93\text{E-}8 \text{ sr}^{-1}$.

Attenuation factor for APS path = 1

Attenuation factor for ETM path = 1

Attenuation factor for SPS path = 1

AR reflectivity of COC = 0.0006

Transmissivity of SM = 0.07

Transmissivity of ETM = 0.07

ratio of anti-symmetric port signal (APS) to input laser power = 0.01

ratio of symmetric port signal (SPS) to input laser power = 0.01

3.1.2.1.1.1 Scattered light requirements

The scattered light requirements for each principal scattering source, at the gravity wave frequencies of interest, are shown in Table 3: Scattered Light Requirements, together with the calculated power scattered into the IFO by that source. 30% of the scattered light budget is used and is allocated to the principal scattering paths proportionally to the relative magnitudes of the particular paths.

The first-order ghost beams from the COC optics will be caught by a beam dump so that the glint from the beam hitting the wall of the chamber will not enter the IFO and exceed the scattered light requirement. Beam dumps will be placed on the following ghost beams:

BS GBHR3X', BS GBHR3Y', BS GBAR1X', BS GBAR3X', BS GBAR3Y', BS GBAR3X, RM GBHR3, RM GBAR3, ITMX GBAR1, ITMX GBHR3, ITMY GBAR1, ITMY GBHR3, ETMX GBAR3, ETMY GBAR3.

Table 3: Scattered Light Requirements

Source	Scattered power allocation factor	Scattered power into IFO, watt	Requirement per source, Ps, watt			Incident power, Pi, watt
			100 Hz	300 Hz	1000 Hz	
AP1	0.0762	1.46E-11	1.46E-11	1.27E-10	5.25E-09	0.030
AP2	0.0652	1.25E-11	1.25E-11	1.08E-10	4.49E-09	0.028
ETMX GBAR2 PO, window scatter	0.0490	3.85E-10	3.85E-10	3.44E-09	1.92E-07	0.327
ETMY GBAR2 PO, window scatter	0.0490	3.85E-10	3.85E-10	3.44E-09	1.92E-07	0.327
ETMX GBAR2 PO	0.0203	1.59E-10	1.59E-10	1.42E-09	7.94E-08	0.327
ETMY GBAR2 PO	0.0203	1.59E-10	1.59E-10	1.42E-09	7.94E-08	0.327
Glint from AP1 lens	0.0153	2.95E-04	2.95E-04	2.55E+01	1.06E+07	0.030

3.1.2.1.1.2 Beam Dump/Baffle Optical Requirements

The scattering and reflectivity properties of the beam dumps/baffles shall satisfy the scattered light noise requirements. These requirements are more than adequately met using the design values for LIGO 1, because the 40m beam dumps/baffles are mounted on SEI platforms, and the optical requirements are reduced by the seismic attenuation factor of the isolation stacks. The derived optical requirements for the LIGO 1 beam dumps are described in COS Beam Dump and Stray Light Baffle Revised Requirements and Concepts LIGO-T980103-00-D, and are presented in the following tables.

Table 4: SEI-mounted Beam Dump Optical Requirements

Parameter	Required Value	Measured Value
Reflectivity	< 1	0.035
Material		DESAG OG 14 filter glass
BRDF	<1E-2 sr ⁻¹	<1.4E-4 sr ⁻¹

Table 5: Arm Cavity Baffle Optical Requirements

Parameter	Required Value	Measured Value
Reflectivity	< 0.3	9E-4
Material		DESAG OG 14 filter glass
BRDF	<1E-2 sr ⁻¹	<1.4E-4 sr ⁻¹

Table 6: Mode Cleaner Baffle Optical Requirements

Parameter	Required Value	Measured Value
Reflectivity	Not specified	0.035
Material		DESAG OG 14 filter glass
BRDF	Not specified	<1.4E-4 sr ⁻¹

3.1.2.1.1.3 Beam Dump/Baffle Mechanical Requirements

The mechanical resonance of the beam dumps and baffles shall not cause excessive scattered light noise due to fringe wrapping. The requirements for the cavity beam dump are analyzed in Up-conversion of Scattered Light Phase Noise from Large Amplitude Motions, LIGO-T980101-00D and are listed in Table 7: Cavity Beam Dump Mechanical Resonance Requirements. The design frequency for the LIGO 1 beam dump was chosen to be > 25 Hz to eliminate fringe-wrap effects with standard LIGO ground motion.

The 40 m beam dumps are mounted to SEI platforms with an attenuation factor of >10E-4 for frequencies above 100 Hz and, although the CIT ground motion is an order of magnitude larger than that at the LHO site, the LIGO 1 fringe wrap requirements will be adequate.

Table 7: Cavity Beam Dump Mechanical Resonance Requirements

Parameter	Required Value	Measured Value
Q factor	< 100	TBD
Onset of fringe-wrapping frequency @ Q=100	8 Hz	
Minimum frequency to eliminate fringe-wrap noise	> 25 Hz with standard LIGO ground motion spectrum	
Maximum Q for negligible beam dump phase noise @ BRDF = 1E-2	< 100	TBD
Beam dump resonance	> 25 Hz	TBD

3.1.2.1.2 Output Beam Attenuator

Attenuators may be needed in the ETMx and ETMy transmission monitor optical paths to reduce the scattered light. A Faraday isolator attenuator in the APS optical path will not be used initially, but may be needed in the future to reduce the scattered light noise.

3.1.2.2 Stray Light Control Physical Characteristics

3.1.2.2.1 Access for Optical lever beams and TV Camera Viewing of COCs

The beam-dump/baffle assemblies shall allow access to the optical lever beams and TV camera viewing of the COC elements. See ASC Optical Lever Design Requirement Document, LIGO-T950106-01-D.

3.1.2.3 Stray Light Control Interface Definitions

3.1.2.3.1 Interfaces to other LIGO detector subsystems

3.1.2.3.1.1 Mechanical Interfaces

The beam dumps/baffles shall bolt to the SEI platforms, in the BSC and HAM chambers, without interfering with the COC mirror structures.

3.1.2.3.1.2 Electrical Interfaces

There are no electrical interfaces for the beam dumps/baffles.

3.1.2.3.1.3 Optical Interfaces

The beam dumps shall intercept the 100ppm diameter of the ghost beams.

3.1.2.3.1.4 Stay Clear Zone

The beam dumps/baffles shall not intercept the 1ppm margin of the main interferometer beam.

3.1.2.4 Stray Light Control Reliability

All Stray Light Control elements are passive and are expected to have 100% availability. The MTBF is expected to be equal to the life of the detector.

3.1.2.5 Stray Light Control Maintainability

Spare components for the replacement of long lead-time items will be stocked.

3.1.3 Stray Light Control Precedence

The relative importance of the positioning of the beam dumps and baffles shall be as follows:

- 1) satisfy the stay clear requirements
- 2) align the baffles and beam dumps with the centers of the ghost beams

3.1.4 Stray Light Control Qualification

N/A

3.2 Initial Alignment System Requirements

3.2.1 Introduction

Initial alignment must set the input IFO laser beam within the range of adjustment of the IFO mirrors so that a transition to acquisition alignment can take place.

3.2.2 Initial Alignment System Characteristics

3.2.2.1 Initial Alignment System Performance Characteristics

- Angular positioning +/- 0.1 mrad (ITM, ETM, BS, PRM, SRM)
- Transverse positioning +/- 2 mm (ITM, ETM)
 +/- 2 mm (BS, RM, SRM)
- Axial positioning +/- 3 mm (ITM, ETM, BS, RM, FM)

3.2.2.2 Initial Alignment System Physical Characteristics

Theodolite / 3-D Coordinate Measuring System

- Telescope Magnification 30x
 Resolving power 3"
 Minimum focus 2m(6.6 ft.)
- Angle Measurement
 Display resolution 0.5"/0.1mgon/0.002mil, 1"/0.2mgon/0.005mil
 Accuracy 2"(0.6mgon) (standard deviation according to DIN 18723)
- Distance Measurement Range
 2m(6.6ft) to 100m(328ft) (RS90 reflective sheets target)
 50m(164ft) to 1000m(3,280ft) (using CPS12 high-precision reflective prism)
- Accuracy
 $\pm(0.8 + 1\text{ppm} \times D)\text{mm}$ (using RS or RT series reflective targets)
 $\pm(2.0 + 2\text{ppm} \times D)\text{mm}$ (using CPS12 high-precision reflective prism)
- General
 Weight
 Main unit 6.1 kg(13.4 lb.), Carrying case 3.9kg(8.6 lb.)

Transit Square

- Telescope:

Length: 14 inches (with micrometer 190)

Magnification: 20X at 2 inches from objective; 30X at infinity

Field of View: 1 degree

Image: Erect

Optics: Low reflective, protective coating

Effective Aperture: 1.34 inches

Resolution: 3.9 arc seconds

Reticle: Glass, filar/bi-filar pattern (others available)

Focusing Range: 2 inches to infinity

Bearings: Ball type with a run out of 0.000025 of an inch or less

Approximate Weight: Instrument, 34 pounds; instrument and case, 54 pounds; shipping, 56 pounds

Laser Autocollimator

Source	Visible laser diode modulated at 10 kHz
Wavelength	670 nm
Peak power	900 μ W (Class II)
Beam diameter	31 mm
Beam divergence	100 μ rad
Beam direction	500 μ rad
Equivalent focal length	280 mm
Measurement field	± 2000 μ rad
Ocular field	± 15 mrad ($\pm 1.1^\circ$)
Resolution	0.1 μ rad
Measurement distortion	± 1 { ± 0.02 x measurement} μ rad (i.e. 2%)
Reflector	Min. 2% reflectivity
Noise	0.02 μ rad/-Hz (at 100% reflectivity)
Weight	1.1 kg

COS Autocollimator

Source	IR laser diode
Wavelength	940 nm
Peak power	5 W (Class IIIB)
Beam diameter	25 mm
Resolution	50 μ rad

3.2.2.3 Initial Alignment System Interface Definitions**3.2.2.3.1 Interfaces to other LIGO detector subsystems***3.2.2.3.1.1 Mechanical Interfaces*

The PLX retro reflector and the optical flat are auxiliary alignment equipment, which will be placed within the vacuum chamber.

3.2.2.3.1.2 Electrical Interfaces

There are no electrical interfaces.

3.2.2.3.1.3 Optical Interfaces

There are no optical interfaces.

3.2.2.3.1.4 Stay Clear Zones

During critical alignments a roped off area of 48” minimum is required to prevent disturbance of the alignment equipment.

3.2.2.4 Initial Alignment System Reliability

There is no published system reliability for alignment instrumentation. Alignment equipment is supplied to each site. In the event of failure the equipment from the alternate site will be available as backup.

3.2.2.5 Initial Alignment System Maintainability

The following calibrations should be performed following shipment, storage or extended use:

Theodolite / 3-D Coordinate Measuring System

- Adjust tilt-sensing error per appendix 2 of Field Manual.
- Check optical plummet accuracy per page 155 of Field Manual.
- Check double centering error per page 149 of Field Manual.

Transit Square

- Check squareness per LIGO T970151-C appendix B.
- Check double centering error per Field Manual.
- Check horizontal axis with vertical wire per Field Manual.

Laser Autocollimator

- Check accuracy per auto calibration kit supplied.

3.2.3 Initial Alignment System Assembly and Maintenance

Assembly fixtures and installation/replacement procedures shall be developed in conjunction with the AOS hardware design. These shall include (but not be limited to) fixtures and procedures for:

- AOS component insertion and assembly into the vacuum chambers without load support from the chambers
- Assembly of the in vacuum components in a clean room (class 100) environment
- Initial alignment of the AOS components

3.2.4 Initial Alignment System Precedence

The relative importance of the Initial Alignment subsystem requirements is as follows:

- 1) Optic position and orientation requirements.
- 2) Reflectivity of core optics at 670 nm.
- 3) Minimizing disturbances to existing core optics, auxiliary optics, and operating equipment.

3.2.5 Initial Alignment System Qualification

During the setup of the PO Mirror and Telescope Subsystem a 940 nm laser autocollimator is introduced into the beam path. This beam is traced thru the corner station optics to verify the positions and orientations of the core optics.

3.3 Optical Lever System Requirements

Suspended Core optics and the final IO optic will be monitored during and after installation by an optical lever system. This system will provide an angular readout of the pitch and yaw angles of the optic with respect to the local facility foundation.

3.3.1 Optical Lever System Characteristics

Optical levers consist of the following elements: a transmitted 633 nm laser beam, steering mirrors to direct the beam to and from the surface of the COC, and an angle-sensing receiver. The layouts of the optical levers are shown in the following figures.

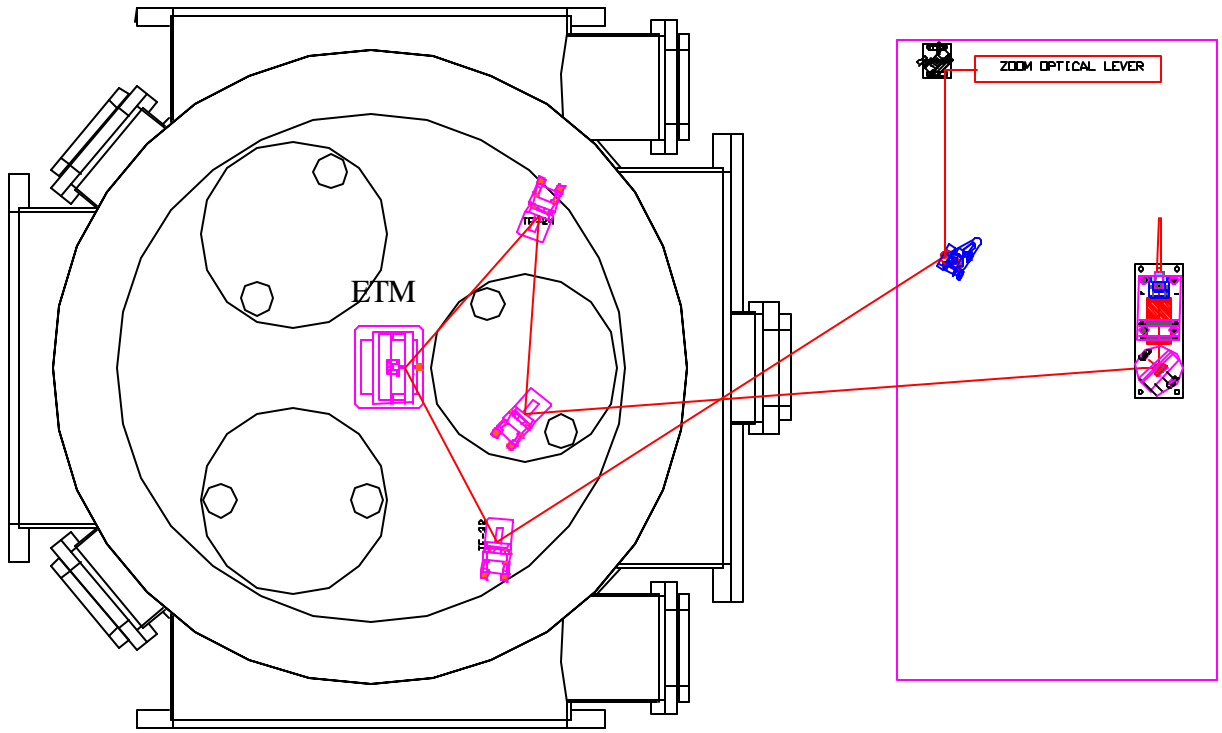

Figure 6: Optical lever, ETMx

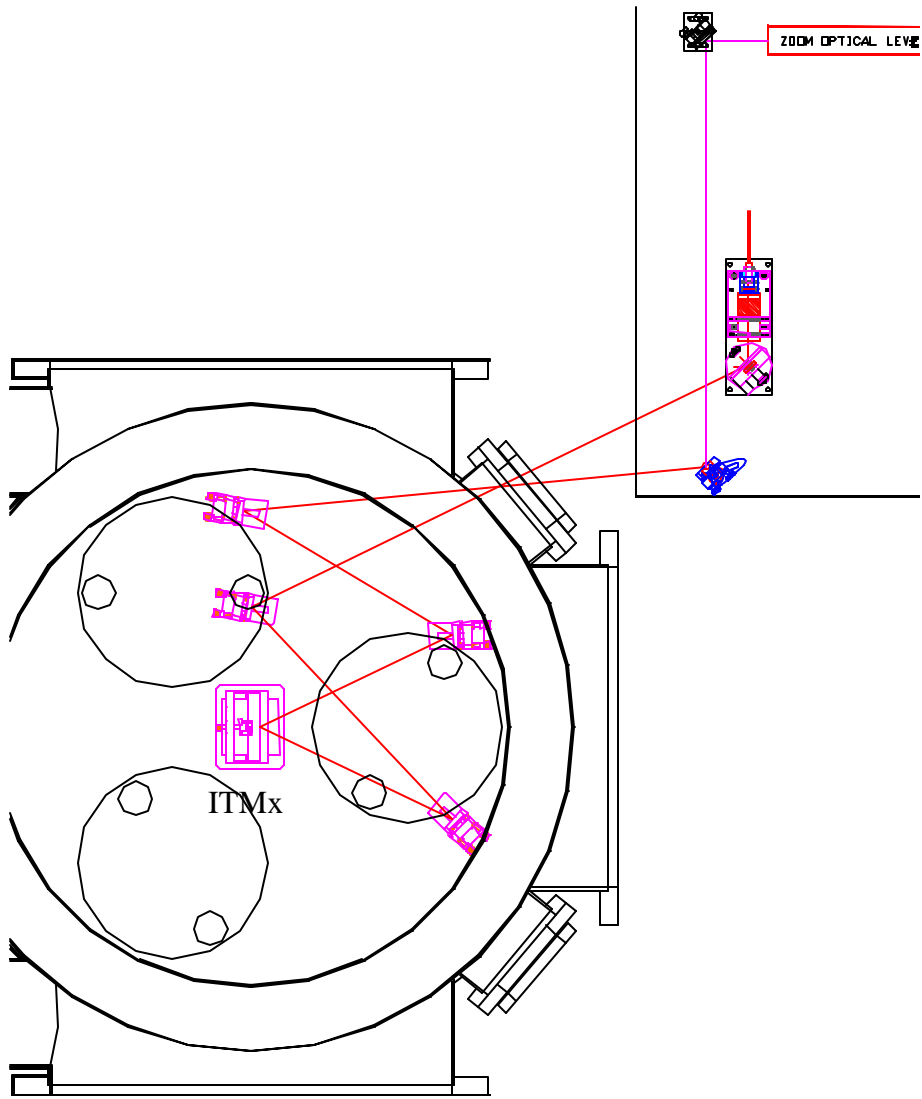

Figure 7: Optical lever, ITMx

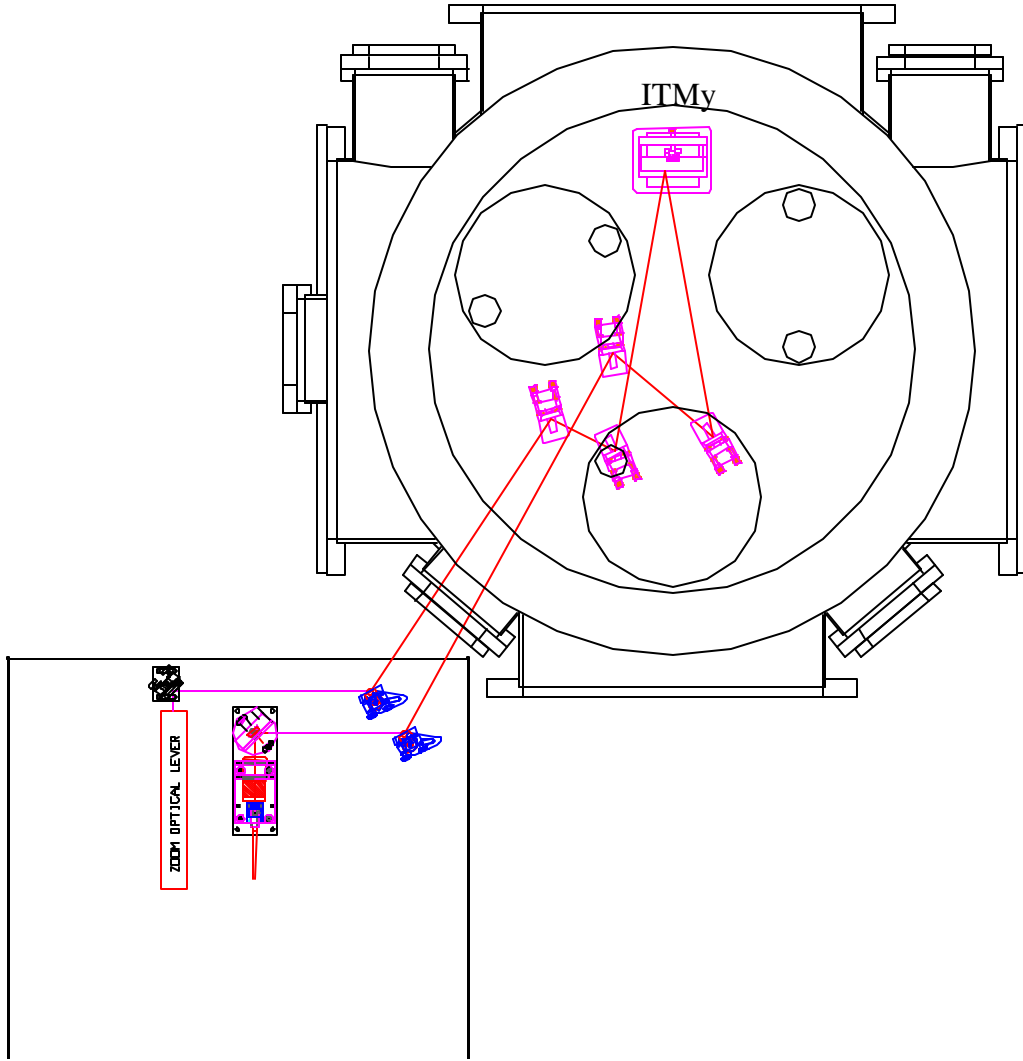

Figure 8: Optical lever, ITMy

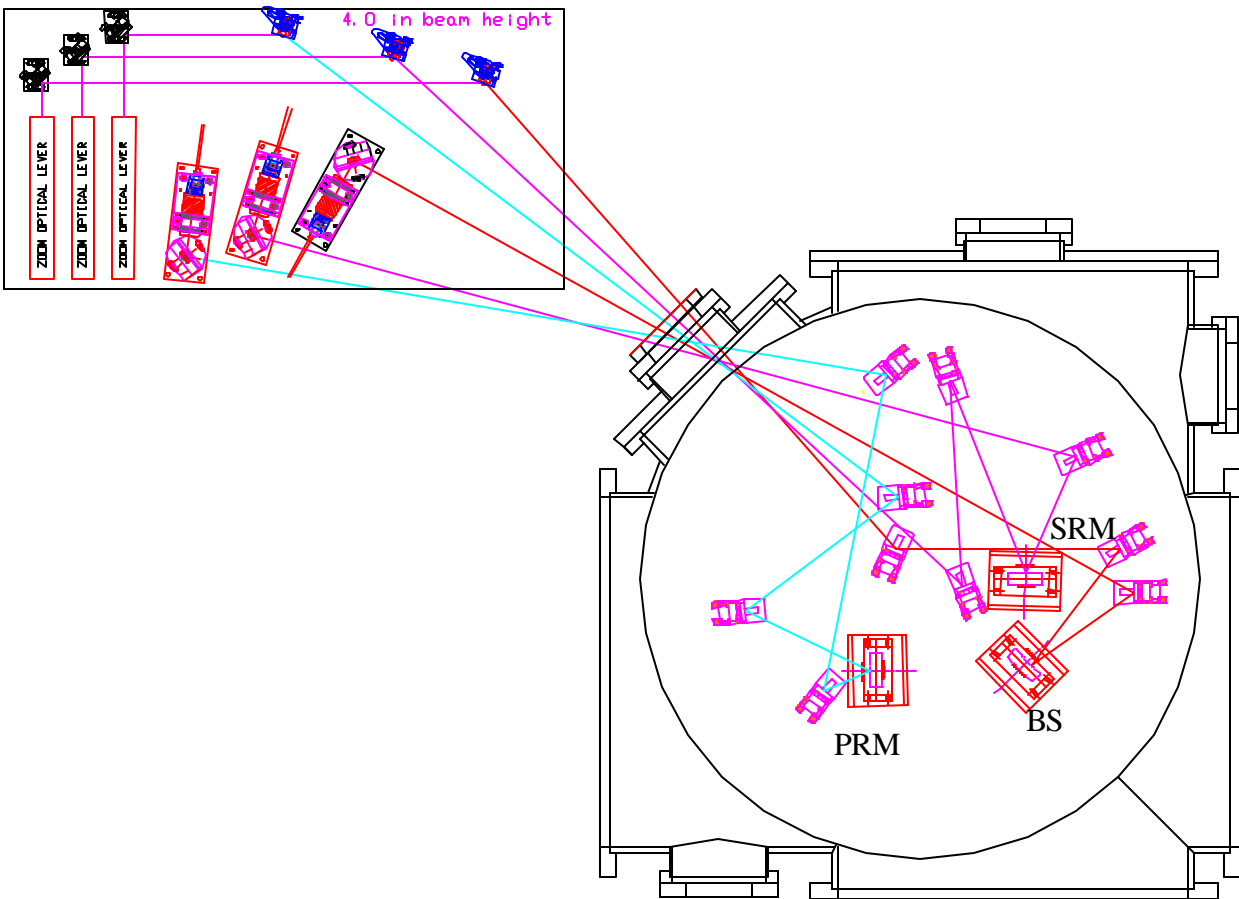

Figure 9: Optical lever, PRM, BS, SRM

3.3.1.1 Optical Lever System Performance Characteristics

The optical lever sensing element shall be insensitive to displacement of the beam and to the quad sensor itself, and shall respond only to angular motion of the lever beam. The optical lever is intended as a reference for core optic alignment to maintain continuity between installation and operation. Its performance is limited by motions of the facility foundations; for example, pump down of a vacuum equipment component section is likely to induce floor tilts of order 100 micro radian, and changes due to cycling temperature gradients in the order of tens of micro radians. However these effects are in principal predictable. As a result the long-term stability of the optical lever performance shall be ± 50 micro radian peaks over extended time periods.

Table 8: Angle sensitivity, zoom optical lever sensor

Parameter	Requirement	Actual
Wavelength, nm		633
Local		
Minimum beam angle, rad	10×10^{-6}	10×10^{-6}
Maximum beam angle, rad	2500×10^{-6}	2500×10^{-6}
Global		
Minimum beam angle, rad	1×10^{-6}	1×10^{-6}
Maximum beam angle, rad	250×10^{-6}	250×10^{-6}
Cross coupling, rad/mm		0
Long term drift, rad	$<50 \times 10^{-6}$	TBD

3.3.1.2 Optical Lever System Physical Characteristics

Plan and elevation views of the optical lever projector are shown in Figure 10: Optical lever projector.

**Figure 10: Optical lever projector**

Table 9: Optical lever system physical characteristics

Parameter	Requirement	Actual
Oplev projector		See figure 10
Laser		TBD
Telescope		TBD
Steering mirror		TBD
Oplev zoom receiver		TBD

The optical levers shall be isolated mechanically from the vacuum chambers and view ports in order to not be effected by pump down or thermal movements of the vacuum system. Flexible bellows will enclose the laser beam and provide isolation for the optical lever systems.

3.3.1.3 Optical Lever System Interface Definitions

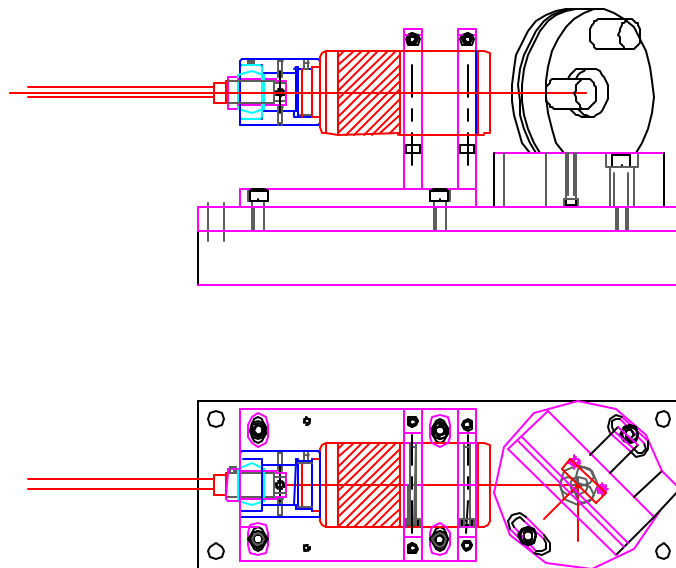
3.3.1.3.1 Interfaces to other LIGO detector subsystems

3.3.1.3.1.1 Mechanical Interfaces

Optical lever structures must be secured directly to the foundation. Examples of accepted structures include rigid stands and seismic piers. The laser source and photodiode assemblies are to be coupled to the vacuum viewports such that no thermal or vacuum induced movement is translated to the optical lever.

3.3.1.3.1.2 Electrical Interfaces

The laser source requires 5v electrical power and current sensing. The photodiode voltage output is fed to the DAQ system for monitoring.

3.3.1.3.1.3 Optical Interfaces

Clearance must be made for optical lever beams to pass through AOS baffles.

3.3.1.3.1.4 Stay Clear Zones

3.3.1.4 Optical Lever System Reliability

Optical lever laser sources shall have a MTBF of 10,000 hours.

3.3.1.5 Optical Lever System Maintainability

The following components are susceptible to failure:

1. Diode laser source assembly.
2. Motorized optic mount.
3. Photodiode assembly.

Each of these items will have plug connections and are easily replaceable. Re-alignment of the laser source and photodiode calibration can be accomplished in less than 1 day.

3.3.2 Optical Lever System Assembly and Maintenance

Assembly installation/calibration documentation shall be developed in conjunction with the optical lever hardware design.

3.3.3 Optical Lever System Precedence

The relative importance of the Optical Lever subsystem requirements is as follows:

1. Long term stability of +/- 50 micro-radians.
2. MTBF of 10,000 hours.
3. Visible wavelength for ease of alignment and troubleshooting.

3.3.4 Optical Lever System Qualification

Calibration of optical levers per LIGO documents T990026-00.

3.4 Video Monitor System Requirements

Video cameras shall provide a view of each COC mirror HR surface so that the position of the 1064 nm spot on the mirror can be determined, as well as an indication of the mode shape of the laser spot.

3.4.1 Video Monitor System Characteristics

The layouts of the video monitors are shown in the following figures.

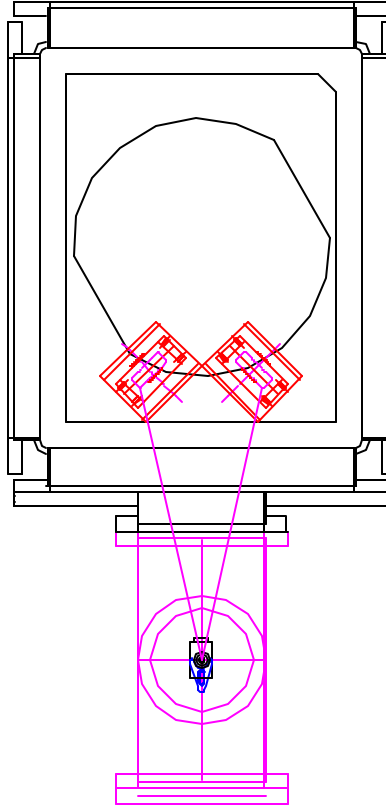

Figure 11: Video monitor for IMC flat mirrors

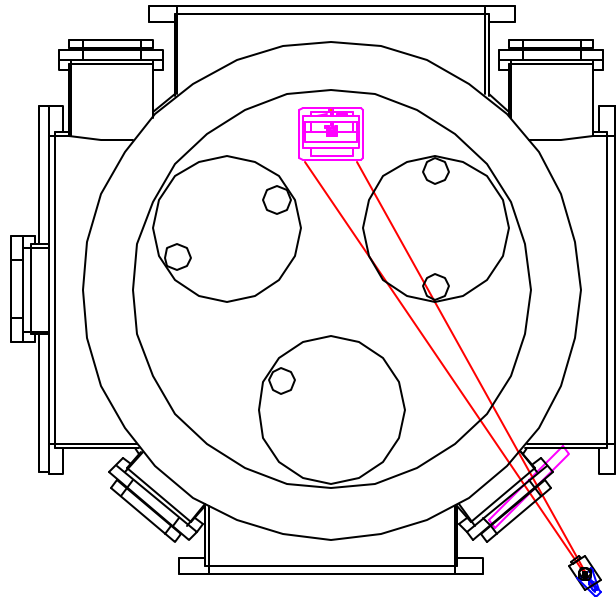

Figure 12: Video monitor for ITMy

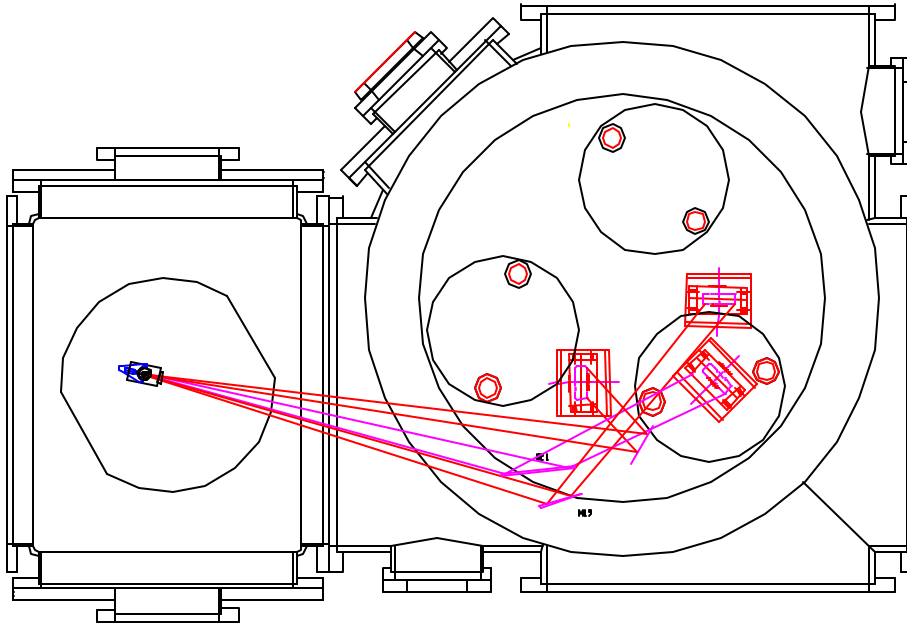

Figure 13: Video monitor for PRM, BS, SRM

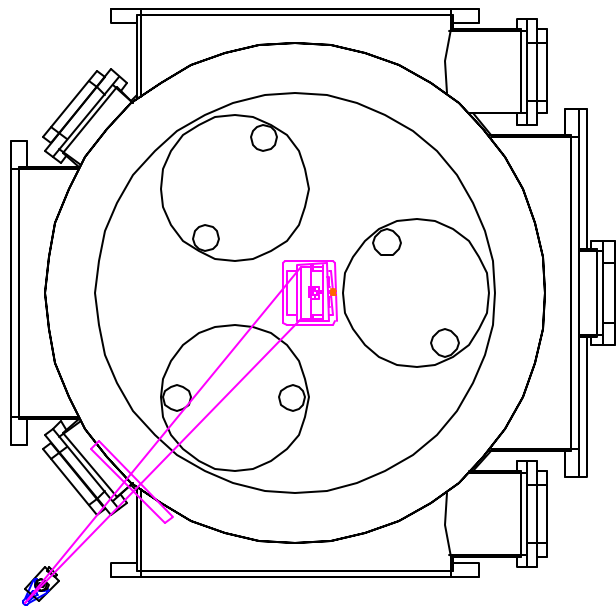

Figure 14: Video monitor for ETMx

3.4.1.1 Video Monitor System Performance Characteristics

Table 10: Video Monitor System Performance Characteristics

Parameter	Requirement	Actual
Wavelength, nm		500 – 1064
Resolution, mm	< 0.5	

3.4.1.2 Video Monitor System Physical Characteristics

Plan and elevation views of the optical lever projector are shown in Figure 10: Optical lever projector.

Table 11: Video Monitor system physical characteristics

Parameter	Requirement	Actual
Video camera		Watek

3.4.1.3 Video Monitor System Interface Definitions

3.4.1.3.1 Interfaces to other LIGO detector subsystems

3.4.1.3.1.1 Mechanical Interfaces

Video cameras will be secured directly to the vacuum housing.

3.4.1.3.1.2 Electrical Interfaces

The cameras require 110VAC power, and a video cable connected to CDS.

3.4.1.3.1.3 Optical Interfaces

Viewing will be done through camera viewports on the sides of the chambers and access “T’s”.

3.4.1.3.1.4 Stay Clear Zones

3.4.1.4 Video Monitor System Reliability

TBD

3.4.1.5 Video Monitor System Maintainability

The video cameras are standard commercial items and will be either repaired or replaced.

3.4.2 Video Monitor System Assembly and Maintenance

Assembly installation/calibration documentation shall be developed.

3.4.3 Video Monitor System Precedence

The relative importance of the Video Monitor subsystem requirements is as follows: **TBD**

3.4.4 Video Monitor System Qualification

TBD

4 General Requirements

4.1 Environmental Conditions

The Optical Systems and Sensing subsystems will operate in a temperature and humidity controlled laboratory environment. Prior to assembly, the components of the Optical Systems and Sensing subsystems will be subjected to normal commercial shipping and handling environments.

4.2 Transportability

All items shall be transportable by commercial carrier without degradation in performance. As necessary, provisions shall be made for measuring and controlling environmental conditions (temperature and accelerations) during transport and handling. Special shipping containers, shipping and handling mechanical restraints, and shock isolation shall be utilized to prevent damage. All containers shall be movable for forklift. All items over 100 lbs. which must be moved into place within LIGO buildings shall have appropriate lifting eyes and mechanical strength to be lifted by cranes.

4.3 Design and Construction

The design and construction of standard purchased parts shall be in accordance with good commercial practices.

The design and construction of the Optical Systems and Sensing subsystem shall allow adequate cleaning, either on site or at an appropriate outside vendor, and shall fit inside the available vacuum baking ovens.

4.3.1 Materials and Processes

The materials and processes shall be compatible with the LIGO approved materials list.

4.3.1.1 Finishes

External surfaces requiring protection shall be painted or otherwise protected in a manner to be approved.

- Metal components shall have quality finishes on all surfaces, suitable for vacuum finishes.
- All materials shall have non-shedding surfaces.
- Aluminum components used in the vacuum shall not have anodized surfaces.

4.3.1.2 Materials

A list of currently approved materials for use inside the LIGO vacuum envelope can be found in LIGO Vacuum Compatible Materials List (LIGO-E960022). All fabricated metal components exposed to vacuum shall be made from stainless steel, copper, or aluminum. Other metals are subject to LIGO approval. Pre-baked viton (or fluorel) may be used subject to LIGO approval. All materials used inside the vacuum chamber must comply with LIGO Vacuum Compatibility, Cleaning Methods and Procedures (LIGO-E960022-00-D).

Only dry-plated lubricating films of vacuum compatible materials such as silver and gold are permitted within the vacuum chamber.

The lenses shall be fabricated from optical grade fused silica substrate with durable AR coatings.

4.3.1.3 Processes

4.3.1.3.1 Welding

4.3.1.3.2 Cleaning

All materials used inside the vacuum chambers must be cleaned in accordance with Specification Guidance for Seismic Component Cleaning, Baking, and Shipping Preparation (LIGO-L970061-00-D). To facilitate final cleaning procedures, parts should be cleaned after any processes that result in visible contamination from dust, sand or hydrocarbon films.

Materials shall be joined in such a way as to facilitate cleaning and vacuum preparation procedures; i.e. internal volumes shall be provided with adequate openings to allow for wetting, agitation and draining of cleaning fluids and for subsequent drying.

Lenses shall be cleaned using standard laboratory optical cleaning procedures.

4.3.1.4 Component Naming

All components shall be identified using the LIGO Naming Convention (LIGO-E950111-A-E). This shall include identification (part or drawing number, revision number, serial number) physically stamped on all components, in all drawings and in all related documentation.

4.3.2 Workmanship

Custom manufactured parts shall be free from defects with a general high quality appearance of the finished product. Workmanship of standard purchased parts shall be in accordance with good commercial practices.

Lenses shall be made in conformance with laser quality commercial practices.

4.3.3 Safety

This item shall meet all applicable NSF and other Federal safety regulations, plus those applicable State, Local and LIGO safety requirements. A hazard/risk analysis shall be conducted in accordance with guidelines set forth in the LIGO Project System Safety Management Plan LIGO-M950046-F, section 3.3.2.

4.3.4 Human Engineering

NA

4.4 Assembly and Maintenance

Assembly fixtures and installation/replacement procedures shall be developed in conjunction with the hardware design. These shall include (but not be limited to) fixtures and procedures for:

- Bench-alignment of optical assemblies

- In site alignment of optical assemblies
- Assembly of the in-vacuum components in a clean room (class 100) environment
- Installation and assembly of components into the vacuum chambers

4.4.1.1.1 Maintainability

Optical elements on external optical benches will require accessibility to they can be cleaned periodically. The MTTR depends upon the cleanliness of the environment.

4.4.1.1.2 Interchangeability

Common elements, with ordinary dimensional tolerances, will be interchangeable. Like commercial optical elements on external optical benches are interchangeable in the optical mounts. However, due to the tolerance on focal lengths, a readjustment of the lens spacing may be necessary to achieve optimum performance.

4.5 Documentation

The documentation shall consist of working drawings, assembly drawings, and alignment procedures.

4.5.1 Specifications

Specifications for the purchase of specialized components and assemblies such as Faraday isolator, optical mirrors, windows, and lenses shall be developed.

4.5.2 Design Documents

The following documents will be produced:

- Preliminary Design Document (including supporting technical design and analysis documentation)
- Final Design Document (including supporting technical design and analysis documentation)
- Installation Procedures

4.5.3 Engineering Drawings and Associated Lists

A complete set of drawings suitable for fabrication shall be provided along with Bill of Material (BOM) and drawing tree lists. The drawings will comply with LIGO standard formats and will be provided in electronic format. All documents shall use the LIGO drawing numbering system, be drawn using LIGO Drawing Preparation Standards, etc.

4.5.4 Technical Manuals and Procedures

4.5.4.1 Procedures

Procedures shall be provided for the following:

- Initial installation and setup of equipment

- Normal operation of equipment
- Normal and/or preventative maintenance
- Installation of new equipment
- Troubleshooting guide for any anticipated potential malfunctions

4.5.4.2 Manuals

Available equipment manuals shall be provided as appropriate.

4.5.5 Documentation Numbering

All documents shall be numbered and identified in accordance with the LIGO documentation control numbering system LIGO document TBD

4.5.6 Test Plans and Procedures

All test plans and procedures shall be developed in accordance with the LIGO Test Plan Guidelines, LIGO document TBD.

4.6 Logistics

The design shall include a list of all recommended spare parts and special test equipment required.

5 Quality Assurance Provisions

This section includes all of the examinations and tests to be performed in order to ascertain the product, material or process to be developed or offered for acceptance conforms to the requirements in section 3.

5.1 General

This should outline the general test and inspection philosophy, including all phases of development.

5.1.1 Responsibility for Tests

Who is responsible for testing?

5.1.2 Special Tests

5.1.2.1 Engineering Tests

List any special engineering tests that are required to be performed. Engineering tests are those that are used primarily for the purpose of acquiring data to support the design and development.

5.1.2.2 Reliability Testing

Reliability evaluation/development tests shall be conducted on items with limited reliability history that will have a significant impact upon the operational availability of the system.

5.1.3 Configuration Management

Configuration control of specifications and designs shall be in accordance with the LIGO Detector Implementation Plan.

5.2 Quality conformance inspections

Design and performance requirements identified in this specification and referenced specifications shall be verified by inspection, analysis, demonstration, similarity, test or a combination thereof per the Verification Matrix, Appendix 1 (See example in Appendix). Verification method selection shall be specified by individual specifications, and documented by appropriate test and evaluation plans and procedures. Verification of compliance to the requirements of this and subsequent specifications may be accomplished by the following methods or combination of methods:

5.2.1 Inspections

Inspection shall be used to determine conformity with requirements that are neither functional nor qualitative; for example, identification marks.

5.2.2 Analysis

Analysis may be used for determination of qualitative and quantitative properties and performance of an item by study, calculation and modeling.

5.2.3 Demonstration

Demonstration may be used for determination of qualitative properties and performance of an item and is accomplished by observation. Verification of an item by this method would be accomplished by using the item for the designated design purpose and would require no special test for final proof of performance.

5.2.4 Similarity

Similarity analysis may be used in lieu of tests when a determination can be made that an item is similar or identical in design to another item that has been previously certified to equivalent or more stringent criteria. Qualification by similarity is subject to Detector management approval.

5.2.5 Test

Test may be used for the determination of quantitative properties and performance of an item by technical means, such as, the use of external resources, such as voltmeters, recorders, and any test equipment necessary for measuring performance. Test equipment used shall be calibrated to the manufacture's specifications and shall have a calibration sticker showing the current calibration status.

6 Preparation for Delivery

Packaging and marking of equipment for delivery shall be in accordance with the Packaging and Marking procedures specified herein.

6.1 Preparation

- Vacuum preparation procedures as outlined in LIGO Vacuum Compatibility, Cleaning Methods and Procedures (LIGO-E960022-00-D) shall be followed for all components intended for use in vacuum. After wrapping vacuum parts as specified in this document, an additional, protective outer wrapping and provisions for lifting shall be provided.
- Electronic components shall be wrapped according to standard procedures for such parts.

6.2 Packaging

Procedures for packaging shall ensure cleaning, drying, and preservation methods adequate to prevent deterioration, appropriate protective wrapping, adequate package cushioning, and proper containers. Proper protection shall be provided for shipping loads and environmental stress during transportation, hauling and storage. The shipping crates used for large items should use for guidance military specification MIL-C-104B, Crates, Wood; Lumber and Plywood Sheathed, Nailed and Bolted. Passive shock witness gauges should accompany the crates during all transits.

For all components that are intended for exposure in the vacuum system, the shipping preparation shall include double bagging with Ameristat 1.5™ plastic film (heat sealed seams as practical, with the exception of the inner bag, or tied off, or taped with care taken to insure that the tape does not touch the cleaned part). Purge the bag with dry nitrogen before sealing.

6.3 Marking

Appropriate identification of the product, both on packages and shipping containers; all markings necessary for delivery and for storage, if applicable; all markings required by regulations, statutes, and common carriers; and all markings necessary for safety and safe delivery shall be provided.

Identification of the material shall be maintained through all manufacturing processes. Each component shall be uniquely identified. The identification shall enable the complete history of each component to be maintained (in association with Documentation “travelers”). A record for each component shall indicate all weld repairs and fabrication abnormalities.

For components and parts that are exposed to the vacuum environment, marking the finished materials with marking fluids, die stamps and/or electro-etching is not permitted. A vibratory tool with a minimum tip radius of 0.005" is acceptable for marking on surfaces that are not hidden from view. Engraving and stamping are also permitted.

7 Notes

7.1 Scattered Light Noise Theory

Light that exits the interferometer either as specular beams, such as the symmetric and antisymmetric signal beams and the beam splitter pick-off beam, or as diffusely scattered light, may be scattered back into the interferometer and will add phase noise to the antisymmetric port signal beam.

The noise/signal ratio due to a particular scattered light source is given by

$$\frac{\tilde{d} h_{Si}}{\tilde{h}_g} = K_i \sqrt{\frac{P_{si}}{P_0}}$$

K_i is the root intensity/noise voltage transfer coefficient¹² for the particular scattering path.

The criteria for the scattered light requirements is that the total scattered light budget from all the scattering sources must not exceed 1/10 the minimum displacement sensitivity of the interferometer.

$$\frac{\tilde{d} h_S}{\tilde{h}_g} = \sqrt{\sum_i (K_i)^2 \frac{P_{si}}{P_0}} \leq \frac{1}{10}$$

The total noise budget can be allocated efficiently among the various scattering sources by estimating the scattered power in each path and by assigning an allocation factor to each source in proportion to the strength of the source. In this manner we can establish a maximum scattered light requirement for each source.

$$F_i = \frac{(K_i)^2 \left(\frac{P_{si}}{P_0}\right)_{REQ}}{\left(\frac{1}{10}\right)^2}$$

The scattered light requirement for each particular source is given by

¹ LIGO-T970071-02, Core Optics Support Design Requirements Document, Michael R. Smith

²LIGO-T970074-00, Secondary Light Noise Sources in LIGO, Jordan Camp

$$\left(\frac{P_{Si}}{P_0} \right)_{REQ} \leq \frac{F_i}{(K_i)^2} \left(\frac{1}{10} \right)^2$$

7.1.1 Noise Allocation Factor

7.1.1.1 K_{RC} Recycling Cavity

The APS (antisymmetric port) output beam will scatter from external windows and from the APS photo-detector, and this scattered light will re-enter the recycling cavity. It will reflect from the input mirror of the arm cavity, and will recombine with the carrier field to produce phase noise on the APS beam.

Similarly, all the pick-off beam from the wedged AR coated surfaces of the RM, BS, and ITMs will scatter from external windows and from sensing photodiodes and will re-enter the recycling cavity and recombine with the carrier beam to produce phase noise.

The K factor for beams that scatter directly into the recycling cavity is filtered by the cavity pole of the arm cavity and is given by the following expression:

$$K_{RC} = \frac{T_{ITM}}{4} \sqrt{\frac{R_{ITM}}{G_{RC}} \left(1 + \left(\frac{f}{f_0} \right)^2 \right)} \frac{\tilde{x}}{\tilde{X}}$$

T_{ITM} is the transmissivity of the input test mass; R_{ITM} is the reflectivity of the input test mass; G_{RC} is the gain of the power recycling cavity; f is the gravity wave signal frequency, f_0 is the arm cavity pole frequency; \tilde{x} is the seismic spectral density; \tilde{X} is the minimum displacement sensitivity.

7.1.1.2 K_{Arm} Arm Cavity

Light that is scattered directly into the arm cavity will build up by the arm cavity gain factor and produce phase noise on the carrier beam. The K factor for the arm cavity is given by the following expression:

$$K_{Arm} := \left(1 + r_{RM} \cdot r_{IFO} \right) \cdot \frac{t_{ITM} \cdot x_s}{t_{RM} \cdot X}$$

$$r_{IFO} = r_{ITM} - \left(\frac{t_{ITM}^2 r_{ETM}}{1 - r_{ITM} r_{ETM}} \right)$$

Where, r_{RM} is the reflection coefficient of the power recycling mirror; r_{ITM} is the reflection coefficient of the input test mass; t_{RM} is the transmission coefficient of the power recycling mirror; t_{ITM} is the transmission coefficient of the input test; r_{ETM} is the reflection coefficient of the end test

mass; r_{IFO} is the reflection coefficient of the arm cavity at resonance; \tilde{x} is the seismic spectral density; \tilde{X} is the minimum displacement sensitivity.

7.1.1.3 K_{SPS} Symmetric Port Signal, and K_{ETM} End Test Mass Transmitted Beam

The K factor for the symmetric port signal is equal to the recycling cavity K factor reduced by the factor of the recycling mirror transmission coefficient; and in addition, the common mode rejection reduces the K factor by the asymmetry factor of the Michelson arms, A_M .

$$A_M := |r_{\text{IFO1}} - r_{\text{IFO2}}|$$

$$K_{\text{SPS}} := K_{\text{APS}} \cdot t_{\text{RM}} \cdot A_M$$

The K factor for the end test mass transmitted beam is equal to the arm cavity K factor reduced by the factor of the end test mass mirror transmission coefficient.

$$K_{\text{ETM}} = K_{\text{Arm}} \sqrt{T_{\text{ETM}}}$$

7.1.1.4 K Values

Table 12: Parameters for the K values

Parameter	Value
Recycling cavity gain	14
Arm cavity power gain	778
Reflection coefficient of PRM	0.95603
Transmission coefficient of PRM	0.26458
ITM reflection coefficient	0.99748
ITM transmission coefficient	0.07071
ETM reflection coefficient	0.99998
ETM transmission coefficient	0.00316
Reflection coefficient of FP @ resonance	-0.98907
Asymmetry coeff. Michelson arms	0.003
Scattering loss from ITM and ETM mirrors	2.75E-05

Table 13 : K values, seismic surfaces

K values, seismic surfaces	Frequency		
	100 Hz	300 Hz	1000 Hz
K-ITM	1.77E+04	6.01E+03	9.33E+02
K-APS	1.77E+04	6.01E+03	9.33E+02
K-ETM	2.76E+03	9.25E+02	1.24E+02
K-SPS	5.67E+01	1.93E+01	2.99E+00
K-RM	5.67E+01	1.93E+01	2.99E+00
K-SM	0.00E+00	0.00E+00	0.00E+00
K-ARM	8.74E+05	2.92E+05	3.91E+04
40 M seismic spectral density, m/Hz ^{0.5}	2.75E-11	4.96E-12	7.58E-13
40 M strain sensitivity, 1/Hz ^{0.5}	1.30E-20	7.00E-21	8.00E-21

7.1.2 Principal Scattering Sources

7.1.3 APS Photodetector

The light power scattered into the interferometer from the APS photodetector is given by the following:

$$P_s = P_i BRDF_{PHOTO} \Delta\Omega \left(\frac{W_0}{W_{APSPHOTO}} \right)^2 T_{APS}$$

The following parameters are used:

Incident power on the window	$P_i = P_0 F_{DPSR}$
BRDF of the APS photodetector	$BRDF_{PHOTO}$
Beam waist at the APS photodetector	$W_{APSPHOTO}$

7.1.4 Beam Glint

All first order ghost beams from the AR surfaces of the PRM, BS, ITM, ETM, and SRM are absorbed on a beam dump or baffle to avoid the direct specular reflection (glint) of the beam into

the IFO from a surface aligned exactly perpendicular to the ghost beam direction, e.g. the chamber wall.

An additional source of light reflected into the IFO is the glint from the surfaces of lenses in the output beam paths, such as the AP1 focus lens. The reflected light power that couples into the IFO mode is proportional to the power of the incident light, to the reflectivity of the surface, and to the glint efficiency for coupling the reflected beam waist into the mode of the IFO.

$$P_g = P_i R \eta$$

The glint efficiencies for the output Faraday isolator and the lenses in the output beam paths are estimated in Table 14: Glint efficiency.

Table 14: Glint efficiency

Parameter	Value
Glint efficiency, AP1 lens	0.00982
Glint efficiency, OMCR lens 1	0.000079
Glint efficiency, OMCR lens 2	1.2E-06
Glint efficiency, output Faraday (@ 1.25E-3 rad tilt)	2.68E-06
AR reflectivity, lens	0.0020