

GDE R&D Program RDR Status and Plans

Barry Barish

GDE

Caltech



ILC Timeline

2005 2006 2007 2008 2009 2010

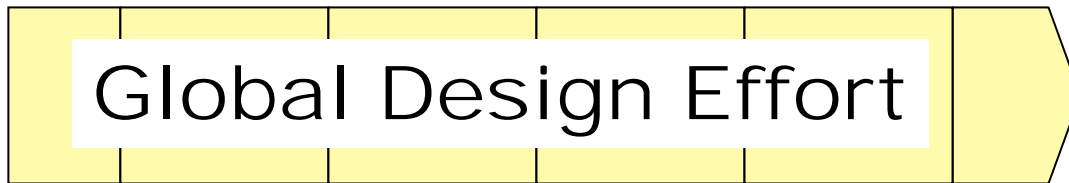

 **Baseline configuration**

 **Reference Design**

 **Technical Design**

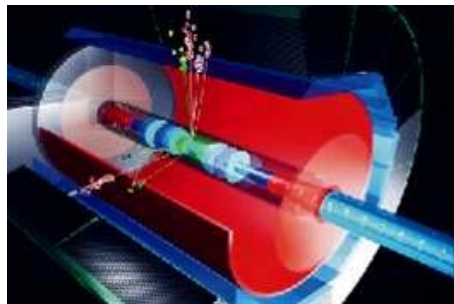

 **ILC R&D Program**

 **Expression of Interest to Host**

 **International Mgmt**



Global Design Effort

– The Mission of the GDE

- Produce a design for the ILC that includes a detailed design concept, performance assessments, reliable international costing, an industrialization plan, siting analysis, as well as detector concepts and scope.
- Coordinate worldwide prioritized proposal driven R & D efforts (to demonstrate and improve the performance, reduce the costs, attain the required reliability, etc.)



GDE RDR / R&D Organization

ICFA

FALC

ILCSC (MAC)

FALC
Resource Board

GDE
Directorate

GDE

GDE
Executive Committee

GDE
R & D Board

GDE
Change Control Board

GDE
Design Cost Board

Global
R&D Program

RDR
Design Matrix



GDE Boards (Feb ILCSC Mtg)

GDE Organizational Evolution for RDR

- **Selected additions to the GDE following the BCD completion having needed skills in design, engineering, costing, etc**
- **Change Control Board**
 - The baseline will be put under configuration control and a Board with a single chair will be created with needed expertise.
- **Design / Cost Board**
 - A GDE Board with single chair will be established to coordinate the reference design effort, including coordinating the overall model for implementing the baseline ILC, coordinating the design tasks, costing, etc.
- **R&D Board**
 - A GDE Board will be created to evaluate, prioritize and coordinate the R&D program in support of the baseline and alternatives with a single chair

GDE Began at Snowmass



**Snowmass
49 GDE members**

**Present
GDE Membership**

| | |
|-----------------|-----------|
| Americas | 22 |
| Europe | 24 |
| Asia | 18 |

About 30 FTEs

*2005 International
and
Snow*

ector Workshop



GDE RDR / R&D Organization

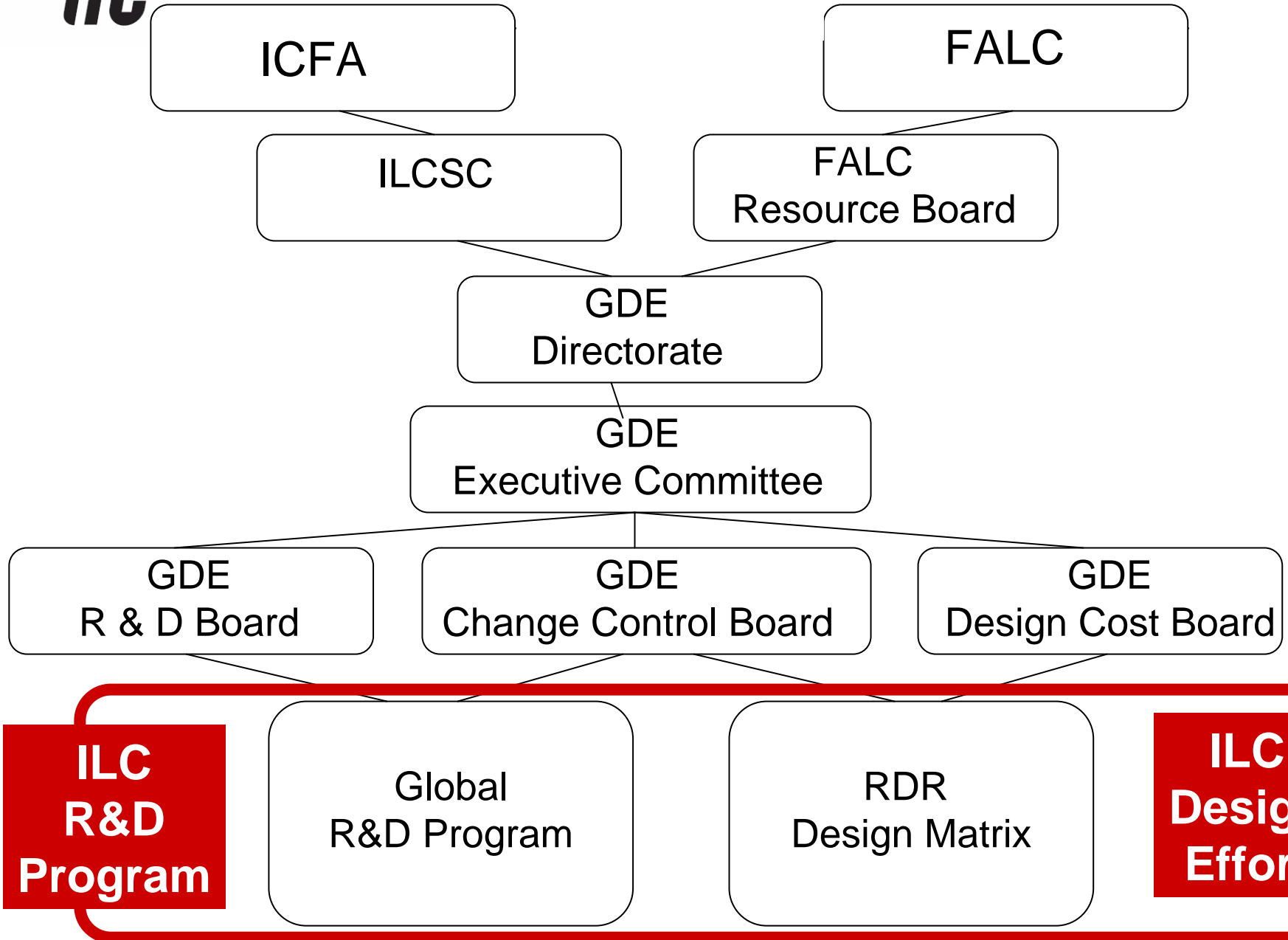



Elements of the ILC R&D Program

- R&D in support of the BCD
 - Technical developments, demonstration experiments, industrialization, etc.
- Proposal-driven R&D in support of alternatives to the baseline
 - Proposals for potential improvements to the baseline, resources required, time scale, etc.
 - Guidance from Change Control Board
- Develop a prioritized **DETECTOR** R&D program aimed at technical developments needed to reach **combined** design performance goals



Mission of the Global R&D Board

- Coordinate worldwide, prioritized, proposal-driven, R & D efforts
- The goal is clear, the detailed means required resolution by the RDB of issues, for example:
 - **Level of coordination**
 - **Parallel efforts coordination, Regional needs**
 - **“Reviewing” role: Ideal vs specific R&D Program**
 - **Balance ILC/ILC Detectors issues**
 - **Goals, Timelines**
 - **Interfaces, RDB/DCB, RDB/Industrialization...**



RDB Board Members and Areas

- Chris Damerell
- Eckhard Elsen
- Terry Garvey
- Hitoshi Hayano
- Toshiyasu Higo
- Tom Himel
- Lutz Lilje
- Hasan Padamsee
- Marc Ross
- Andy Wolski
- Bill Willis (Chair)

AREAS

SC CAVITIES,
CRYOGENICS,
BEAM DELIVERY,
INJECTOR,
LINAC PERFORMANCE,
INSTRUMENTATION,

CRYOMODULES,
DAMPING RINGS,
POWER SOURCE,
CONTROLS,
HIGH AVAILABILTY,

*******DETECTORS*******



RDB Plan for Achieving its Mission

- First tackle work that leads to immediate benefits
 - **Project Tools to allow a Work Breakdown structure to put all Global R&D on a common basis, needs:**
 - A Data Entry Tool
 - A Data Base with flexible features
 - A facility for generating needed Reports
 - **CERN has kindly agreed to help us with the Data Base and Reports, and our Board member Eckhard Elsen agreed to be Data Integrator to make the system work**
- Generate an Ideal ILC Research Program



Ideal ILC R&D Program

- Generate WBS for ten ILC Areas (no Cryogenics R&D identified for the Baseline), with about 400 items
- The structure will allow us to note links items in different Regions
- Assign Priorities 1 (very high), 2 (high), 3 (moderate), 4 (low)
 - **by team of two Board members per area, with justification**
 - **Reviewed anonymously by all members, with comments**
 - **Discussion of board to reach conclusion**
 - **Face to face meeting to consider uniformities among areas 8 March**
 - **“Last” iteration took place this week**
- Publication (RDB Public Wiki) took place this week
<http://www.linearcollider.org/wiki/doku.php>
- Convenient Reports will be created from the data base at CERN soon, useful for example for Dugan 2007 meeting in May



Small sample of Data Entry

| | | | | | | | |
|---------------------------|-------------|--|-----------|--------|---------|-------------|--|
| SC_HOM_2K_Cryoload | SC_HOM | HOM induced cryoload at 2K | high | DESY | | undefined | Measure cryogenic HOMs at 2K to be s as required to keep |
| SC_HOM_Improve_Existing | SC_HOM | Improve existing design | high | DESY | KEK | in progress | Slight modifications design for ease of f rejection, and therr |
| SC_HOM_Absorber_Material | SC_HOM | HOM absorber material | high | DESY | Cornell | in progress | Work on reproducit material. |
| SC_HOM_Feedthroughs | SC_HOM | Higher heat conductivity feedthroughs | moderate | TJNAF | DESY | in progress | Explore higher hea output lines |
| SC_HOM_Alternate | SC_HOM | Alternate HOM couplers | moderate | TJNAF | KEK | undefined | Explore alternate H |
| SC_HOM_Output_Parallel | SC_HOM | HOM output in F-piece plane | moderate | TJNAF | KEK | undefined | Radial positioning o plane of so called F |
| SC_HOM_Hidden_Capacity | SC_HOM | HOM: Hidden capacitor | moderate | TJNAF | KEK | undefined | Version of HOM cou |
| SC_HOM_No_Capacity | SC_HOM | HOM: No capacitor | moderate | TJNAF | KEK | undefined | Version of HOM cou |
| SC_Tuner | SC | Tuner | | | | | |
| SC_Tuner_Fast_Range | SC_Tuner | Increase fast tuning range | very high | Saclay | KEK | in progress | Design with increas |
| SC_Tuner_Fast_Actuator | SC_Tuner | Fast actuator R&D | very high | Orsay | | in progress | Fast actuator R&D |
| SC_Tuner_35 | SC_Tuner | Prototype tests at 35 MV/m | high | | | | Prototype tests witt MV/m |
| SC_Tuner_MTBF | SC_Tuner | MTBF for cold motor | high | | | undefined | Verification of suffic |
| SC_Tuner_TJNAF | SC_Tuner | Renascence tuner | moderate | TJNAF | | undefined | TJNAF Renascence |
| SC_Tuner_KEK | SC_Tuner | KEK screwball tuner | high | KEK | | in progress | KEK coaxial ball scr for balls, Weight re |
| SC_Tuner_Redundancy | SC_Tuner | Tuner redundancy | high | | | undefined | Develop Redundant vessel |
| SC_Tuner_Warm_Motor | SC_Tuner | Warm tuner motor | low | | | undefined | Explore Warm motc |
| SC_Tuner_Magnetostrictive | SC_Tuner | Magnetostrictive tuner | moderate | | | in progress | Explore larger strok detailed characteriz |
| SC_Tuner_Reliability | SC_Tuner | Tuner reliability | high | | | undefined | Conduct Reliability piezo / magnetrostri mechanisms and in |
| CM | Accelerator | Cryo Module | | | | | |
| CM_4th_gen | CM | Development of a 4th generation cryomodule | high | FNAL | KEK | in progress | Type IV cryomodule from Type III+ : S cavity centerline loc cavity support deta rods) Same input c |



ILC R&D Program Coordination

- From the MAC Report
 - *“The committee believes that a very aggressive, world-wide, well-coordinated, R&D program is necessary to defend the case of an accelerating gradient as large as 35 MV/m. The committee recommends that this R&D effort have a very high priority in the overall ILC R&D plan. The committee would like to learn about the plan at its next meeting”*
- The Gradient – Baseline is 35 MV/m
 - Cavity fabrication and processing
 - Testing
 - The GDE has a small task force of experts and will produce a specific “realistic” plan in 1-2 months.
- How to implement the plan? Regional interests vs global goals and priorities



Superconducting RF Cavities

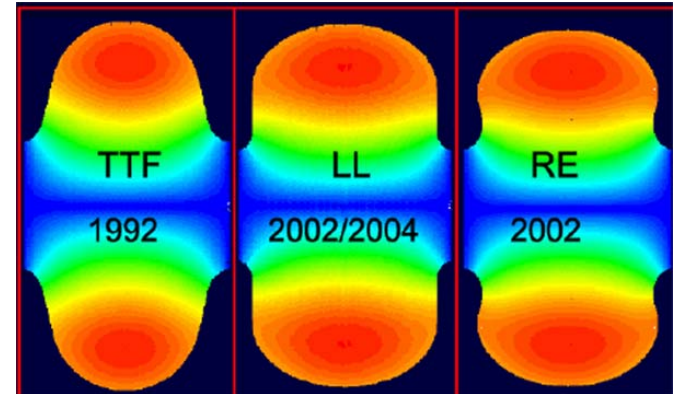

Chemical Polish



Electro Polish

- **Electropolishing Studies @ DESY**

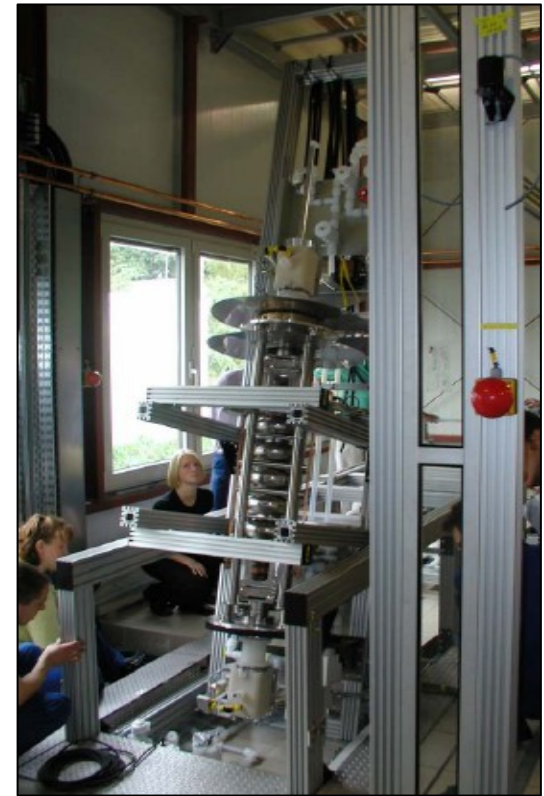
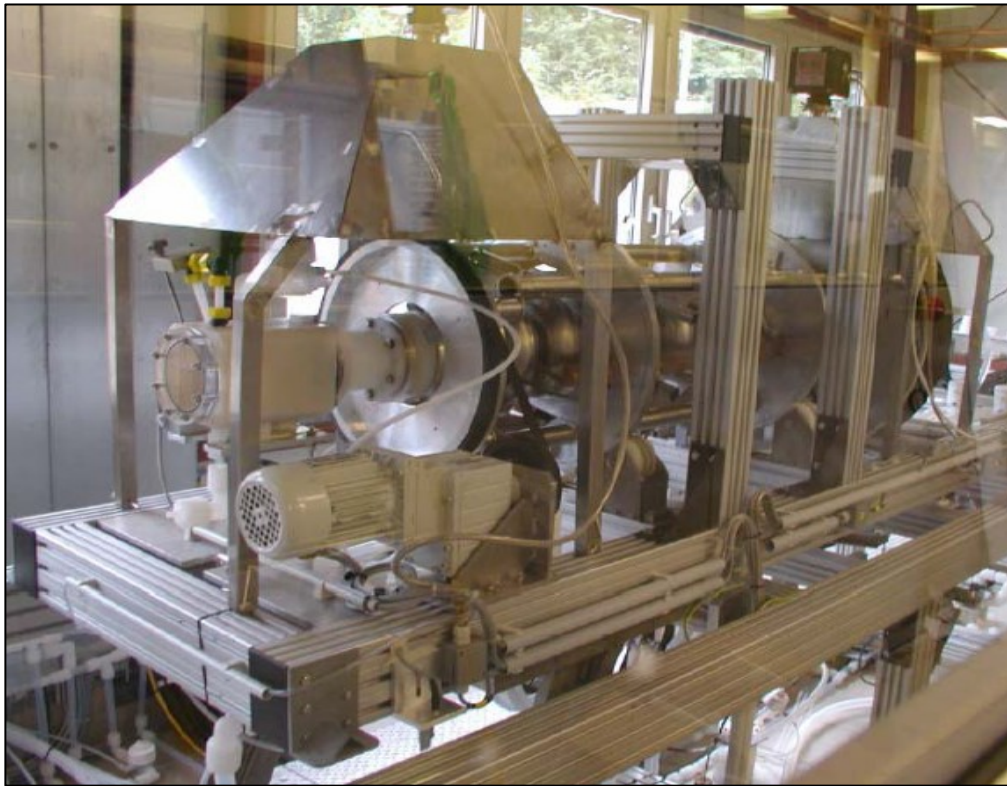



TESLA Test Facility Linac - DESY

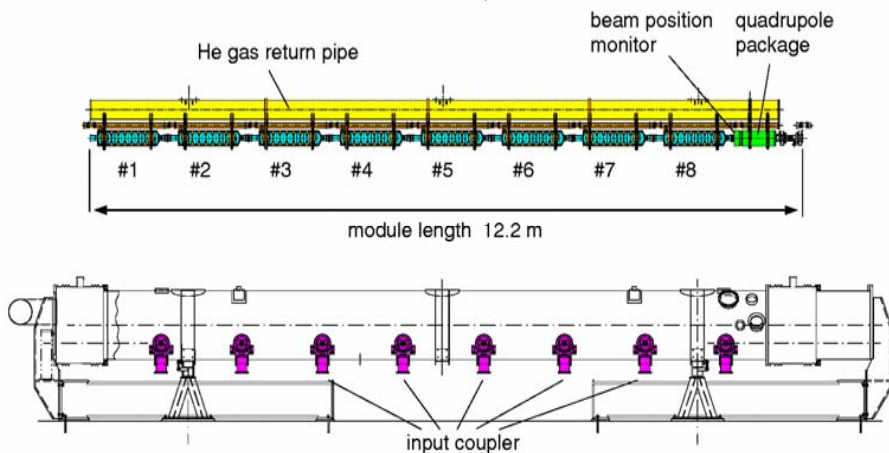
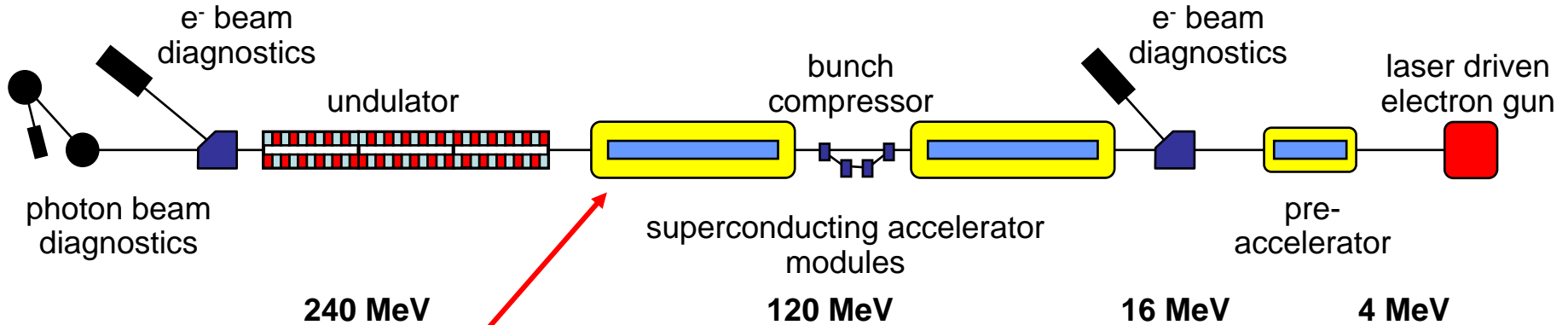



Fermilab – SCRF Test Facility

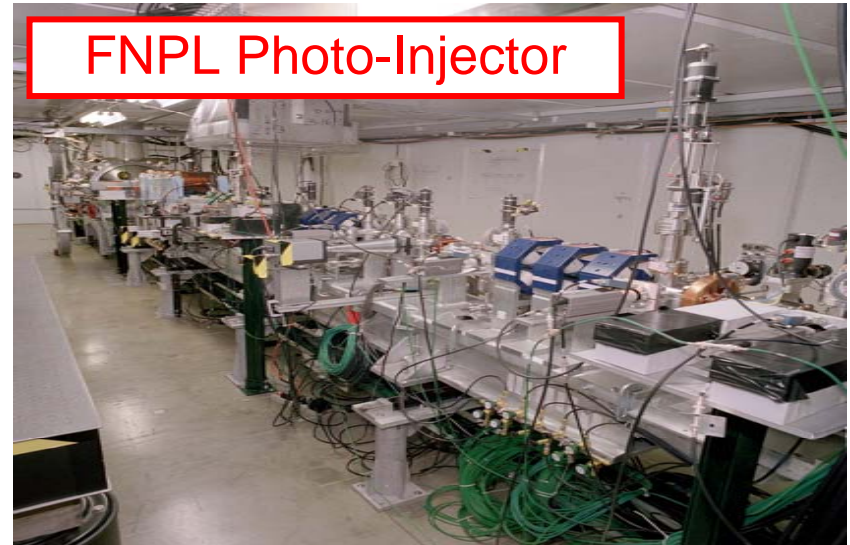

- ILC cryomodule string test facility planned for the New Muon Lab
- Upgraded FNPL will provide beam tests of ILC cryomodules (FY08 and 09)

Plan of Superconducting RF Test Facility (STF)

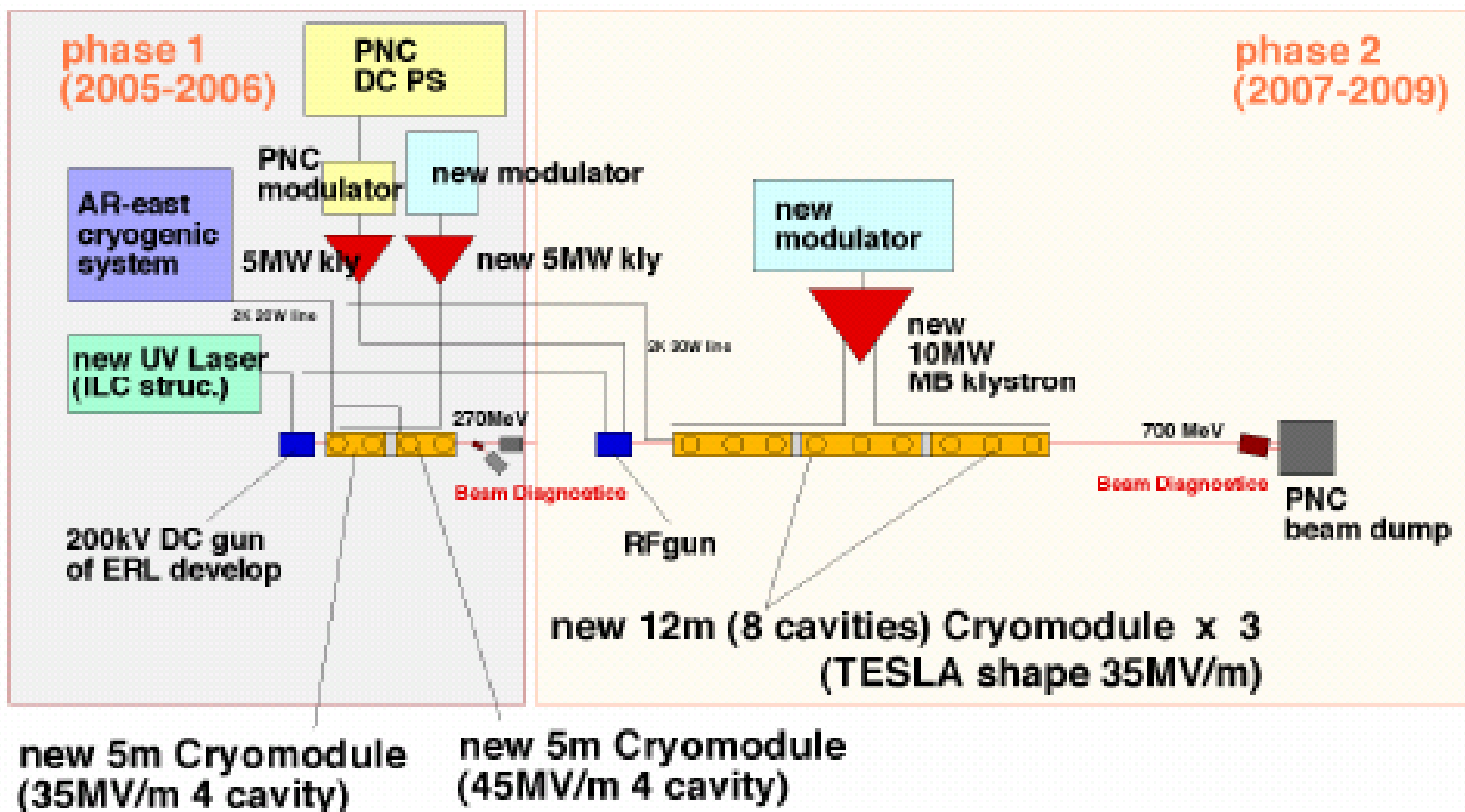

V3.0 Hitoshi Hayano, 12/02/2005

RF Power: Baseline Klystrons



Specification:
10MW MBK
1.5ms pulse
65% efficiency

At present, we do not have a klystron that performs. How to focus R&D on this issue.

- Developing these multibeam Klystrons; develop alternatives (e.g. sheet beam); consider dropping back to 5 MW



ILC R&D Issues

- How to coordinate the regional large efforts to focus on program goals, like establishing baseline gradient?
- How to focus R&D as “problems arise,” like the 10MW klystron issue?
- What role to play in the worldwide detector R&D program?



Coordinating the RDR

- RDR Management Group (Walker, Chair)
 - Guides the design/cost efforts on day by day basis
 - Composition - Accelerator Leaders (Walker, Raubenheimer, Yokoya); Cost Engineers (Shidara, Garbincius, Bialowons); Integration Scientist (Paterson)
- Coordinate both ILC design work and costing
- Reviews are to be conducted by Design Cost Board
- First Costing by Vancouver to have time for cost reductions by value engineering, scope options ...

RDR Matrix

| | e- source | e+ source | Damping Rings | RTML | Main Lina c | BDS |
|--------------------------|-----------|-----------|---------------|------|-------------|-----|
| Vacuum systems | X | X | X | X | X | X |
| Warm magnet systems | X | X | X | X | (X) | X |
| Cryomodule | X | X | (X) | X | X | (X) |
| Cavity Package | X | X | (X) | X | X | (X) |
| RF Power | X | X | (X) | X | X | (X) |
| Cryogenics | X | X | X | X | X | X |
| Accelerator Physics | X | X | X | X | X | X |
| Operations & Reliability | X | X | X | X | X | X |
| Instrumentation | X | X | X | X | X | X |
| Controls | X | X | X | X | X | X |
| Systems integration | X | X | X | X | X | X |
| CF&S | X | X | X | X | X | X |
| Cost | X | X | X | X | X | X |

ILC Cryomodule

Increase diameter beyond X-FEL

Increase diameter beyond X-FEL

Review 2-phase pipe size and effect of slope

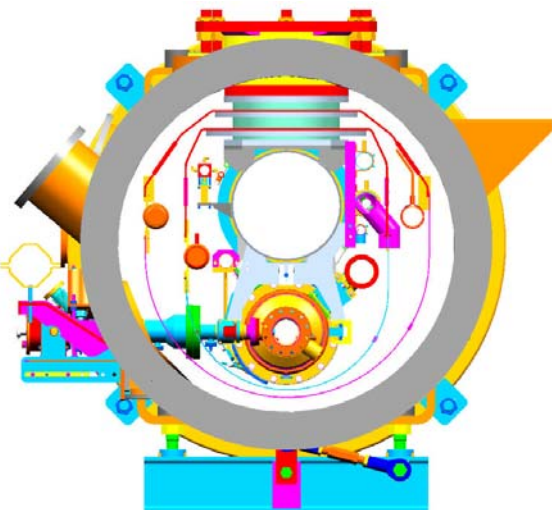
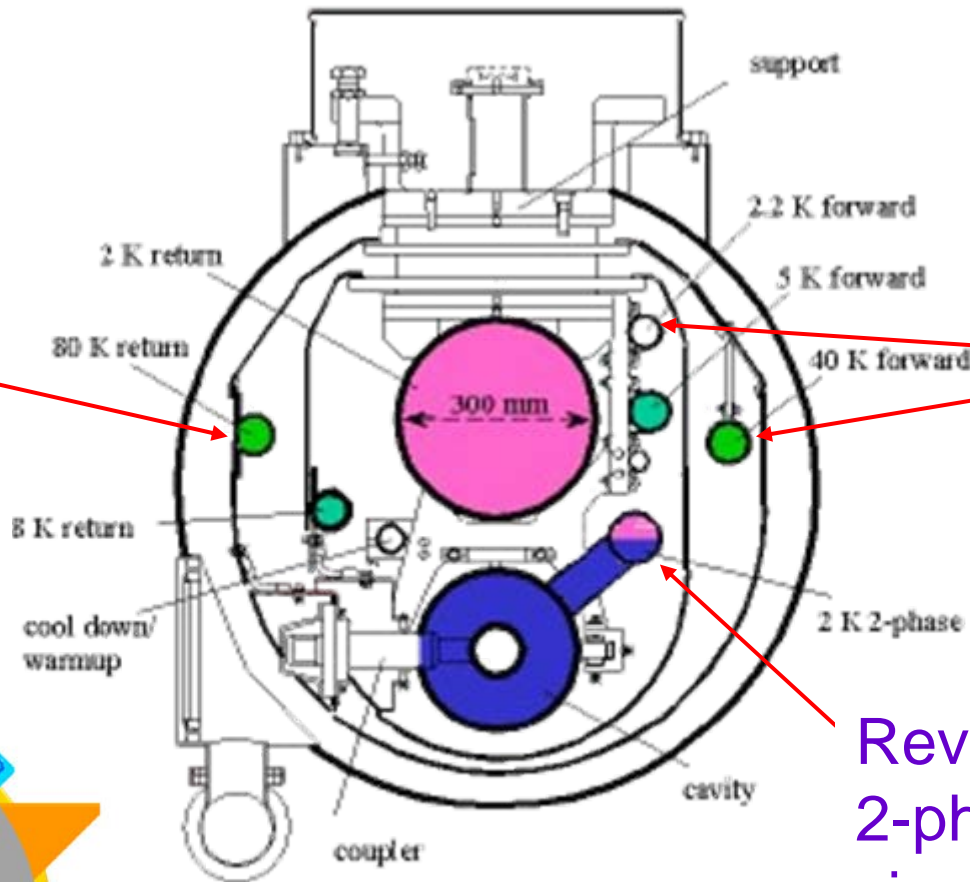



Damping Ring Design Issues

Electron Cloud

- Ecloud: Threshold of electron cloud, $1.4 \times 10^{11} \text{ m}^{-3}$.
- Ion: Feedback system can suppress for 650 MHz (3ns spacing),
- number of bunch in a train 45, and gap between trains 45ns..

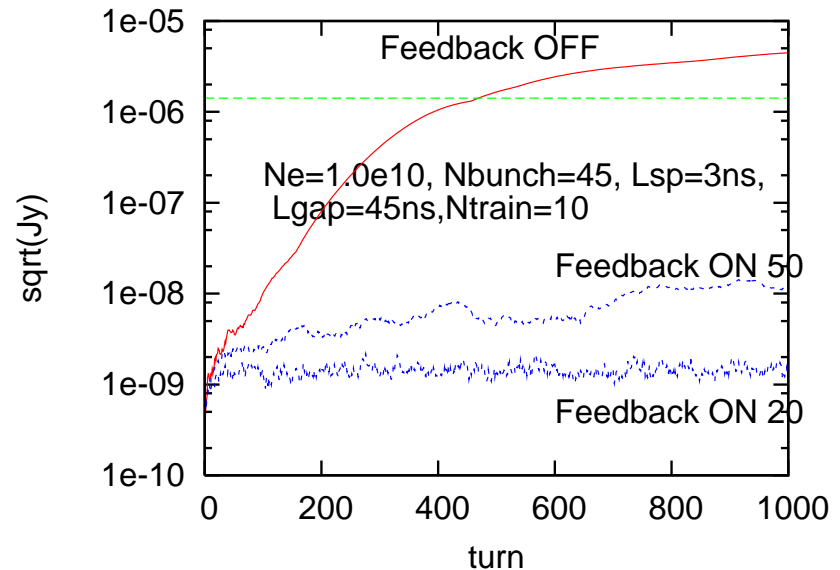
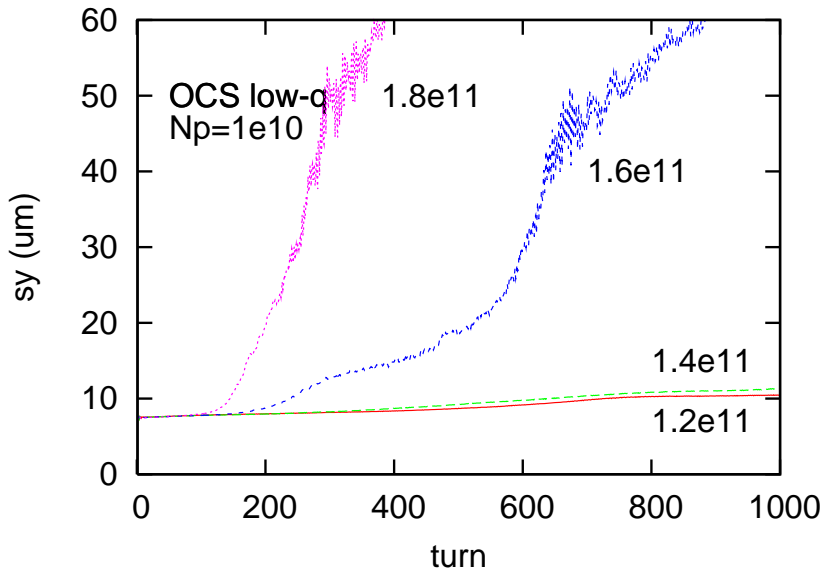



RDR Cost Estimating

- 500 GeV BCD machine + “essentials” for 1 TeV
- Follow ITER “Value” & CERN “CORE” model for International Projects
 - Provides basic agreed to costs [common “value” + in-house labor (man-hr)]
- RDR will provide information for translation into any country’s cost estimating metric, e.g. Basis of Estimate => contingency estimate, in-house labor, G&A, escalation, R&D, pre-construction, commissioning, etc.
- Assumes a **7 year** construction phase



ILC Cost Estimate

- Based on a call for world-wide tender:
lowest reasonable price for required quality
- Classes of items in cost estimate:
 - **Site-Specific (separate estimates for each site)**
 - **Conventional – global capability (single world est.)**
High Tech – cavities, cryomodules, regional estimates
- Cost Engineers will determine how to combine and present multiple estimates
- WBS ; WBS Dictionary; Costing Guidelines are mature enough - cost estimating is underway



WBS Level of Detail - Cryogenics

| | | | | | |
|---|---|---|---|--|--|
| % | percentage of total materials cost for USLCTOS 500 GeV Cold option | | | | |
| | these percentages for USLCTOS are somewhat sensitive, | | | | |
| | they are listed just to give idea of level of detail that has been attained | | | | |
| WB 6feb_PG 8feb | (follows USLCTOS) | | This is what is on the web, the items 1.8.3.1.1.i | | |
| 1.8.3 | Cryogenic Plant and Distribution | | were omitted. The green numbers on left are | | |
| 4.08 | 1.8.3.1 | Cryogenic Plants | percentage 4.08% of total USLCTOS 500 cold M&S | | |
| 3.27 | 1.8.3.1.1 | Cryo Refrigeration Unit (includes cryo distribution, but not civil utilities) | | | |
| This layer was not included - consider adding this layer to increase sensitivity | | | | | |
| 1.12 | 1.8.3.1.1.1 | Cryo Cold Boxes | | | |
| 0.68 | 1.8.3.1.1.2 | Cryo Warm Compressor System | | | |
| 0.12 | 1.8.3.1.1.3 | Cryo Cold Compressor System | | | |
| 0.11 | 1.8.3.1.1.4 | Cryo Purification System | | | |
| 0.13 | 1.8.3.1.1.5 | Cryo Refrigeration System Controls | | | |
| 0.10 | 1.8.3.1.1.6 | Cryo Liquid Helium Storage | | | |
| 0.17 | 1.8.3.1.1.7 | Cryo Vertical Transfer Line | | | |
| 0.16 | 1.8.3.1.1.8 | Cryo Distribution Boxes 1,2,8 | | | |
| 0.11 | 1.8.3.1.1.9 | Cryo Distribution Boxes 3,6,7 | | | |
| 0.16 | 1.8.3.1.1.10 | Cryo Warm He Gas Header | | | |
| 0.09 | 1.8.3.1.1.11 | Cryo Vacuum Barriers | | | |
| 0.19 | 1.8.3.1.1.12 | Cryo System Installation Contracts | | | |
| 0.04 | 1.8.3.1.1.13 | Cryo Miscellaneous | | | |
| 0.05 | 1.8.3.1.1.14 | Cryo Feed Boxes | | | |
| 0.04 | 1.8.3.1.1.15 | Cryo End Boxes | | | |
| 0.25 | 1.8.3.1.2 | Cryo Cooling Towers | | | |
| 0.04 | 1.8.3.1.3 | Cryo Warm Helium Storage | | | |
| 0.04 | 1.8.3.1.4 | Cryo Helium Gas (initial charge) - should this be operating, not construction? | | | |
| 0.00 | 1.8.3.1.5 | Cryo Vacuum Barrier | | | |
| 0.01 | 1.8.3.1.6 | Cryo Feed Boxes | | | |
| 0.01 | 1.8.3.1.7 | Cryo End Boxes | | | |
| 0.17 | 1.8.3.1.8 | Cryo Load Controls | | | |
| 0.30 | 1.8.3.1.9 | Cryo Cold Bypass (1 kilometer) - what was this? fairly pricey! | | | |
| | 1.8.3.2 | Cryogenic Distribution - actually included above 1.8.3.1.1.i - so can discard this element | | | |

LHC refrig.
single units

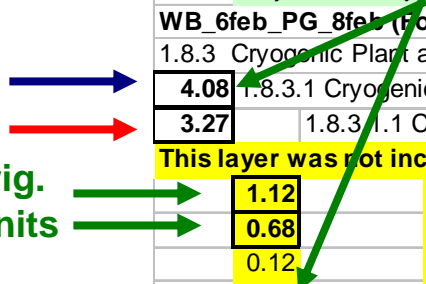



Cost Roll-ups

Area Systems

e-
source

e+
source

damping
rings

RTML

main
linac

BDS

Technical Systems

Vacuum systems

Magnet systems

Cryomodule

Cavity Package

RF Power

Instrumentation

Dumps and Collimators

Accelerator Physics

Global Systems

Commissioning, Operations &
Reliability

Control System

Cryogenics

CF&S

Installation

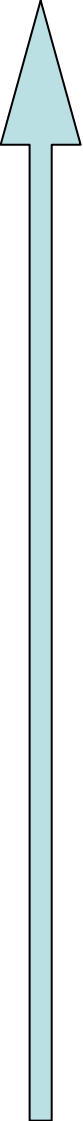
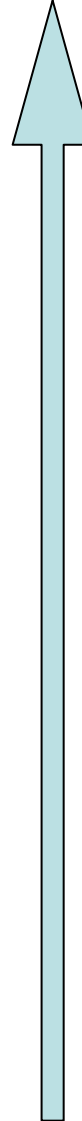
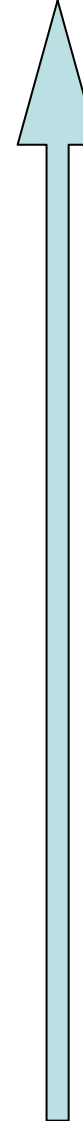
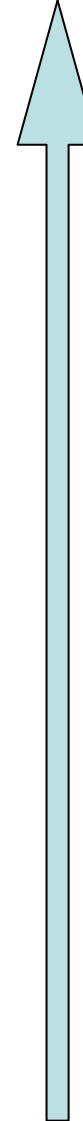
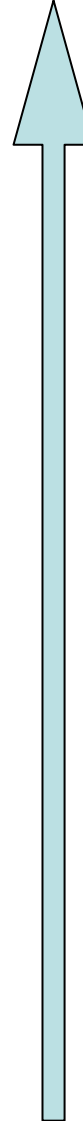
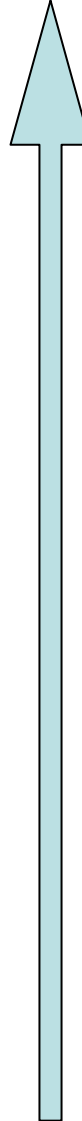



From Baseline to a RDR

2006

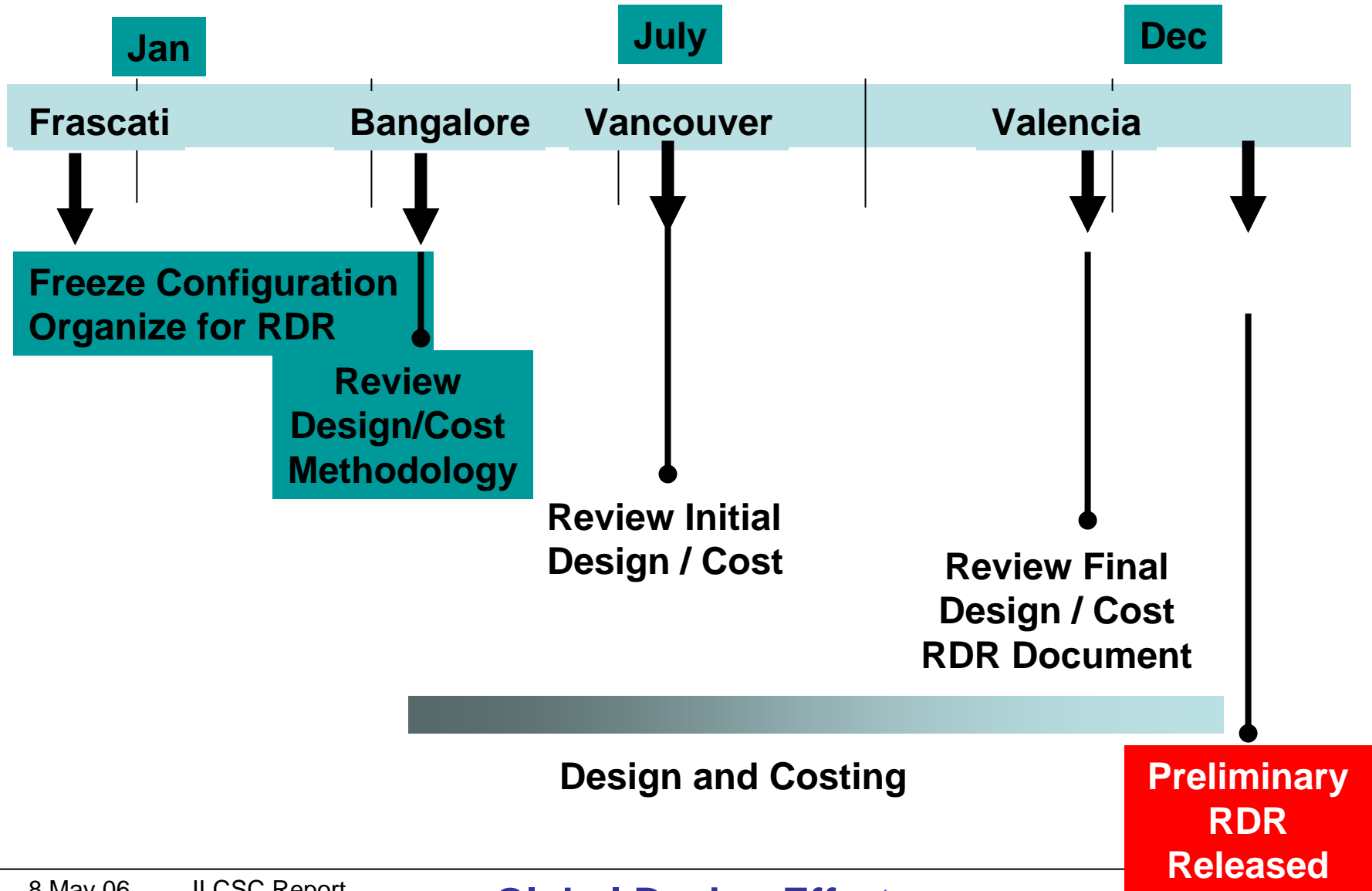



RDR Goals

- The BCD is now being used as the basis for the reference design / cost effort this year.
- It is being evolved through a formalized change control process
- Our goal is to produce a consistent design for the ILC, capable of delivering design performance.
- We will make every attempt to contain costs for the basic machine, while determining costs on an “international basis.”
- The design will continue to evolve following the RDR, as the R&D provides more CCB actions.



ILC Design / Cost -- Issues

- How to maintain confidentiality as costing information becomes available?
 - Information available on “as needed basis”
 - Limited set of individuals
- Cost reduction studies
 - Who is included and when in the dialogue
- COMMENT
 - The effort to do the design / costing requires skilled engineers, designers and cost people. These are not in the GDE, but the laboratories and need to be made available. Looking forward to the TDR this will be a major problem

RDR Matrix

| | e- source | e+ source | Damping Rings | RTML | Main Linac | BDS |
|--------------------------|-----------|-----------|---------------|------|------------|-----|
| Vacuum systems | X | X | X | X | X | X |
| Warm magnet systems | X | X | X | X | (X) | X |
| Cryomodule | X | X | (X) | X | X | (X) |
| Cavity Package | X | X | (X) | X | X | (X) |
| RF Power | X | X | (X) | X | X | (X) |
| Cryogenics | X | X | X | X | X | X |
| Accelerator Physics | X | X | X | X | X | X |
| Operations & Reliability | X | X | X | X | X | X |
| Instrumentation | X | X | X | X | X | X |
| Controls | X | X | X | X | X | X |
| Systems integration | X | X | X | X | X | X |
| CF&S | X | X | X | X | X | X |
| Cost | X | X | X | X | X | X |