

The International Linear Collider

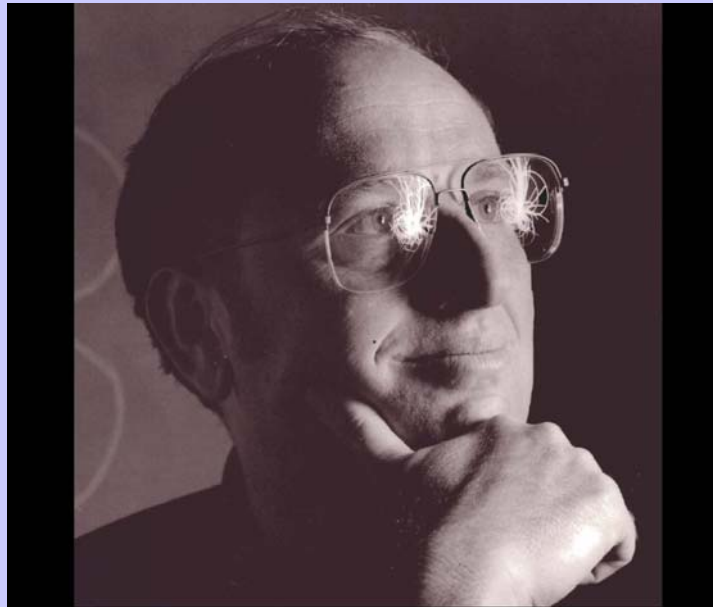

Barry Barish
Caltech

Abe-Fest, Carmel Mission Inn
11-Sept-06

Particle Physics

Inquiry Based Science

1. Are there undiscovered principles of nature:
New symmetries, new physical laws?
2. How can we solve the mystery of dark energy?
3. Are there extra dimensions of space?
4. Do all the forces become one?
5. Why are there so many kinds of particles?
6. What is dark matter?
How can we make it in the laboratory?
7. What are neutrinos telling us?
8. How did the universe come to be?
9. What happened to the antimatter?

from the Quantum Universe

Answering the Questions

Three Complementary Probes

- **Neutrinos as a Probe**
 - Particle physics and astrophysics using a weakly interacting probe
- **High Energy Proton Proton Colliders**
 - Opening up a new energy frontier (~ 1 TeV scale)
- **High Energy Electron Positron Colliders**
 - Precision Physics at the new energy frontier

Accelerators and the Energy Frontier

Large Hadron Collider CERN – Geneva Switzerland



Electroweak Precision Measurements

Winter 2003

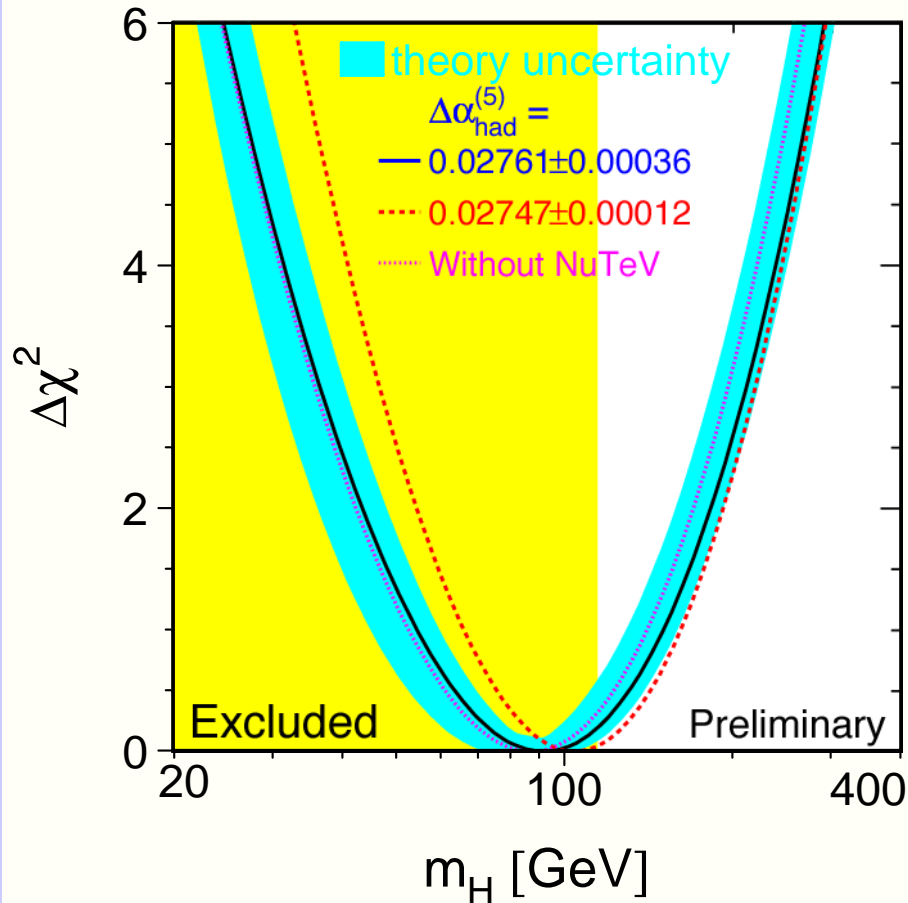

What causes mass??

The mechanism –
Higgs or alternative
appears around the
corner

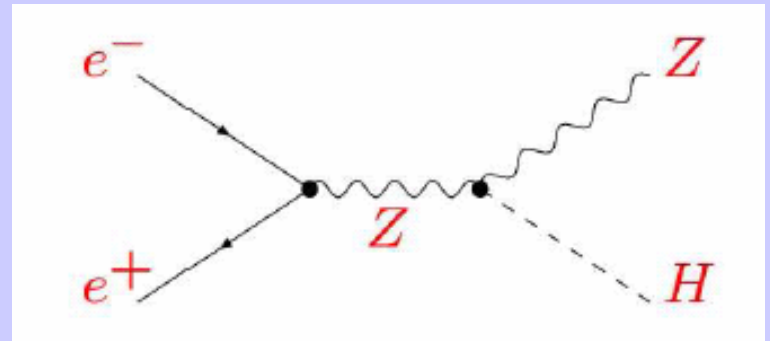

LHC and the Energy Frontier

Source of Particle Mass

Discover the Higgs

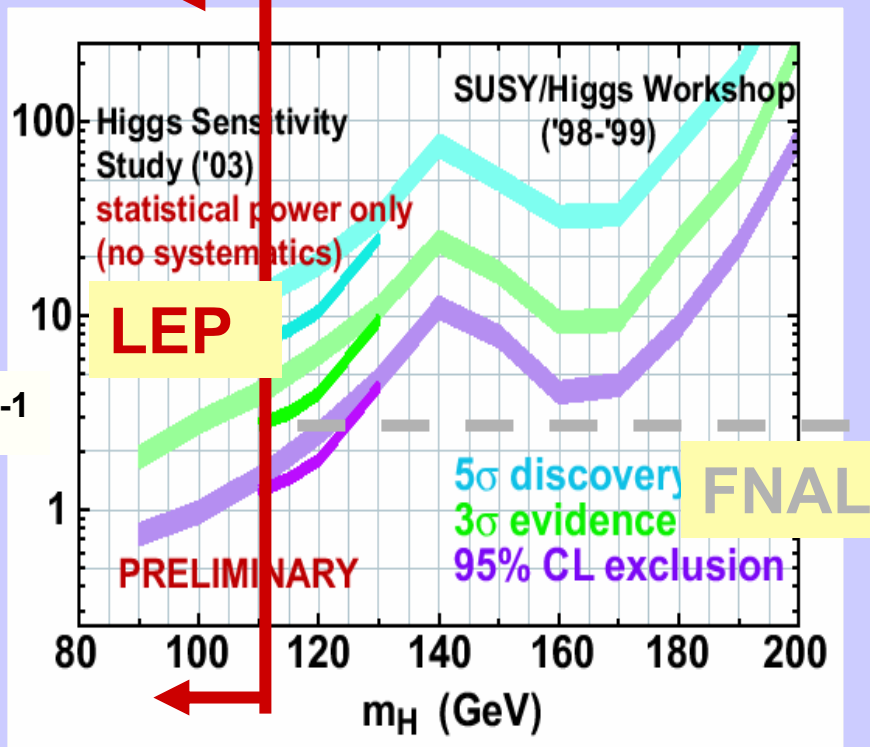

The Higgs Field

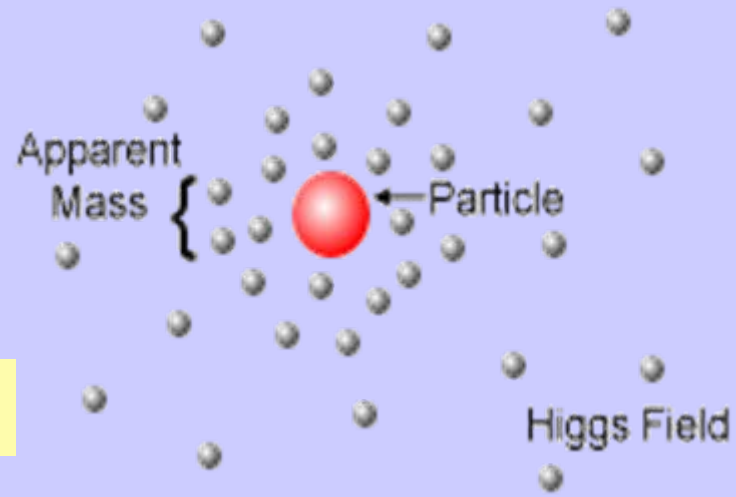

or variants or ???

LHC and the Energy Frontier

A New Force in Nature

mass janZp1.5

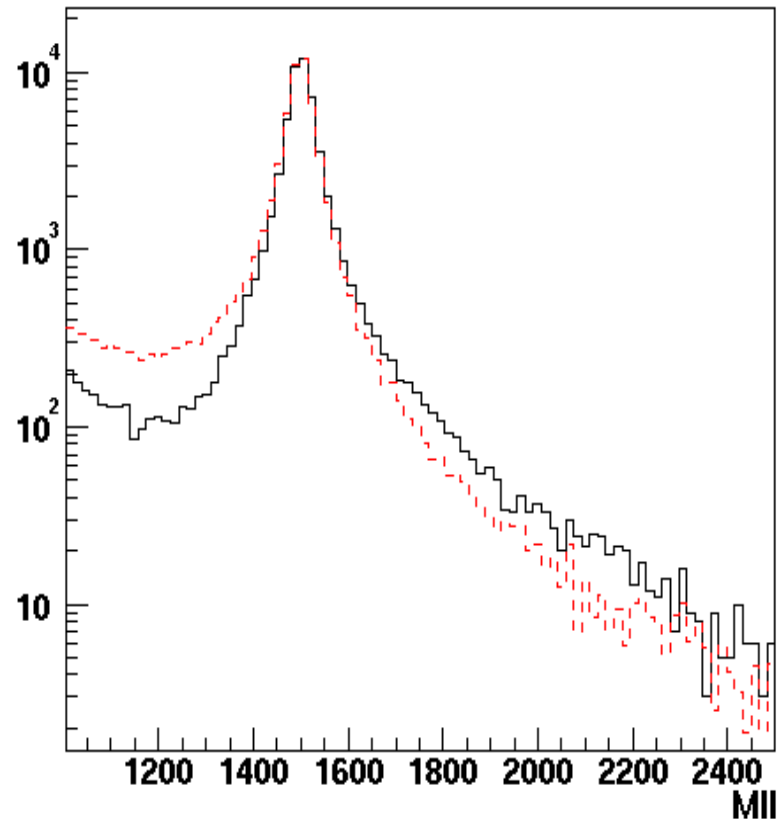

Discover a new heavy particle, Z'

Can show by measuring the couplings with the ILC how it relates to other particles and forces

Why e^+e^- Collisions ?

- elementary particles
- well-defined
 - energy,
 - angular momentum
- uses full COM energy
- produces particles democratically
- can mostly fully reconstruct events

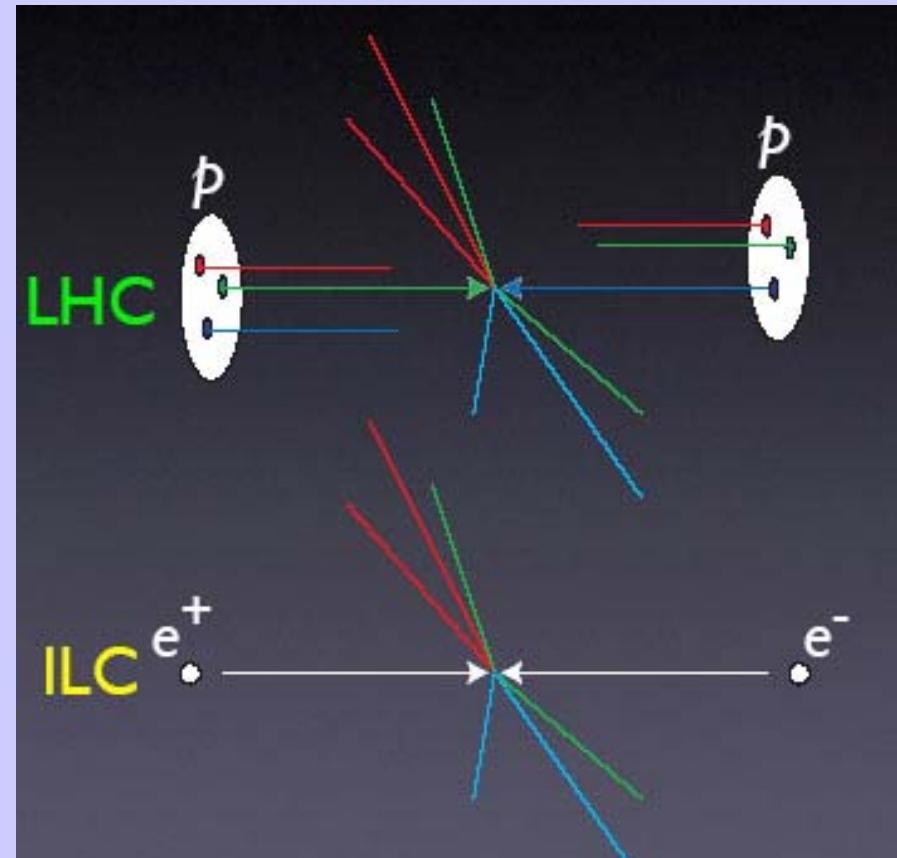

How do you know you have discovered the Higgs ?

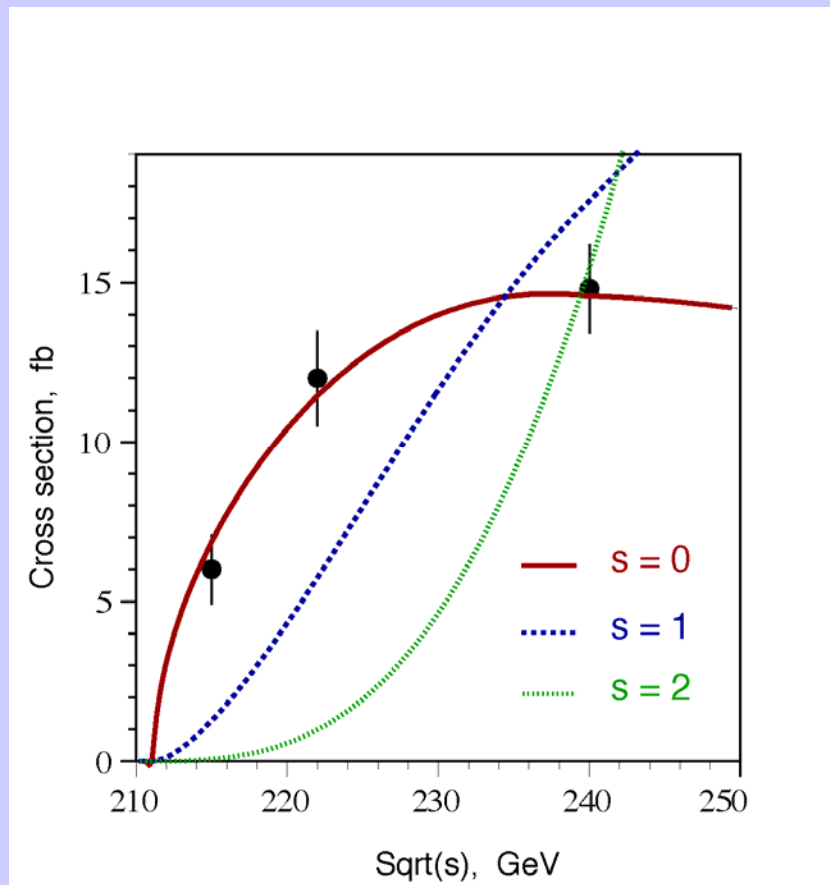

Measure the quantum numbers. The Higgs must have spin zero !

The linear collider will measure the spin of any Higgs it can produce by measuring the energy dependence from threshold

The ILC measures coupling strength of the Higgs with other particles

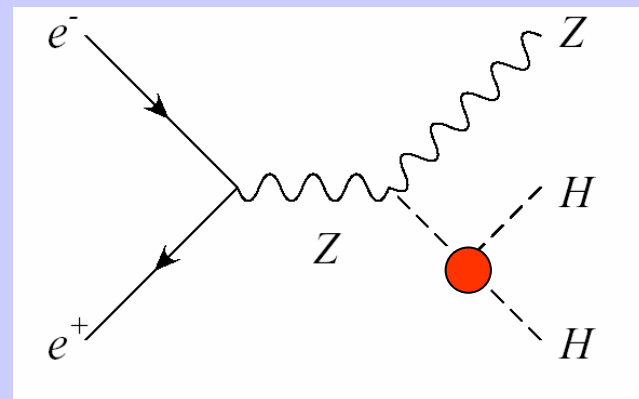
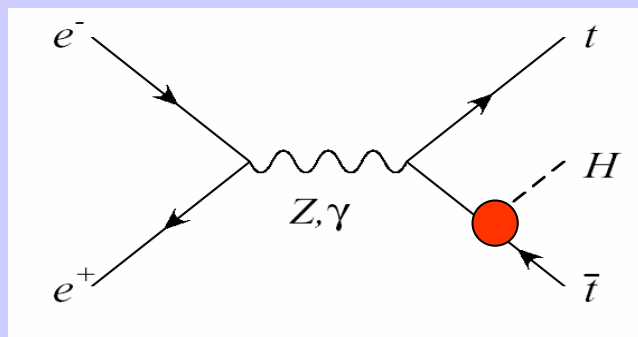
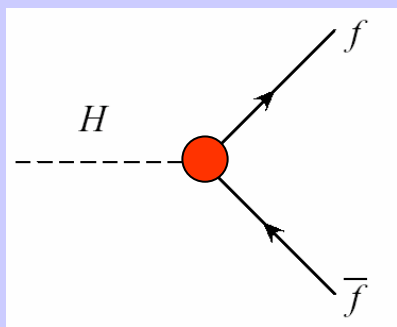

Higgs Coupling-mass relation

$$m_i = v \times \kappa_i$$

What can we learn from the Higgs?

Precision measurements of Higgs coupling can reveal extra dimensions in nature

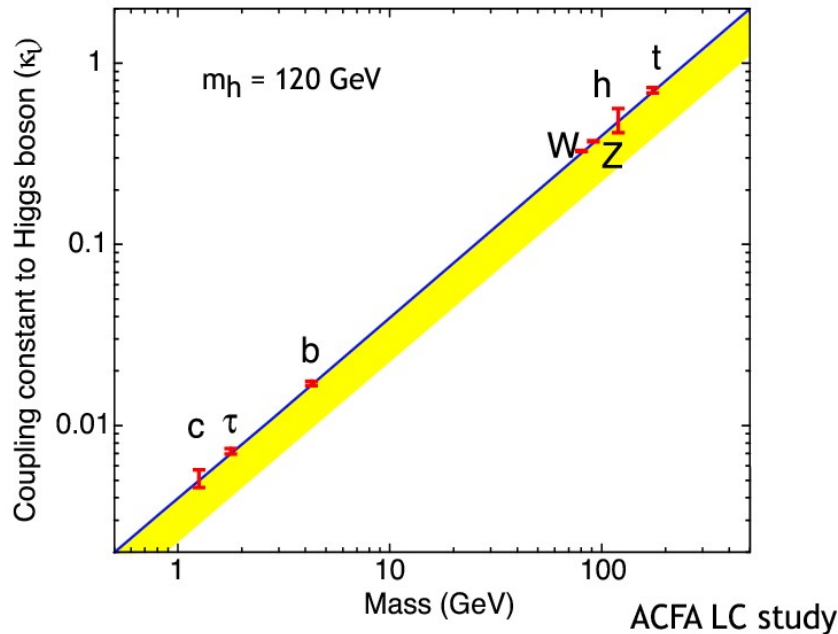

- Straight blue line gives the standard model predictions.
- Range of predictions in models with extra dimensions -- yellow band, (at most 30% below the Standard Model)
- The red error bars indicate the level of precision attainable at the ILC for each particle

Direct production from extra dimensions ?

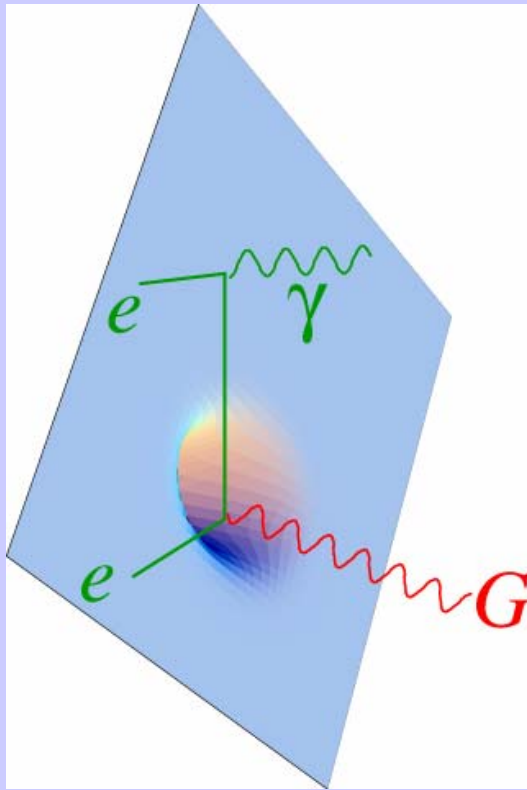

New space-time dimensions can be mapped by studying the emission of gravitons into the extra dimensions, together with a photon or jets emitted into the normal dimensions.

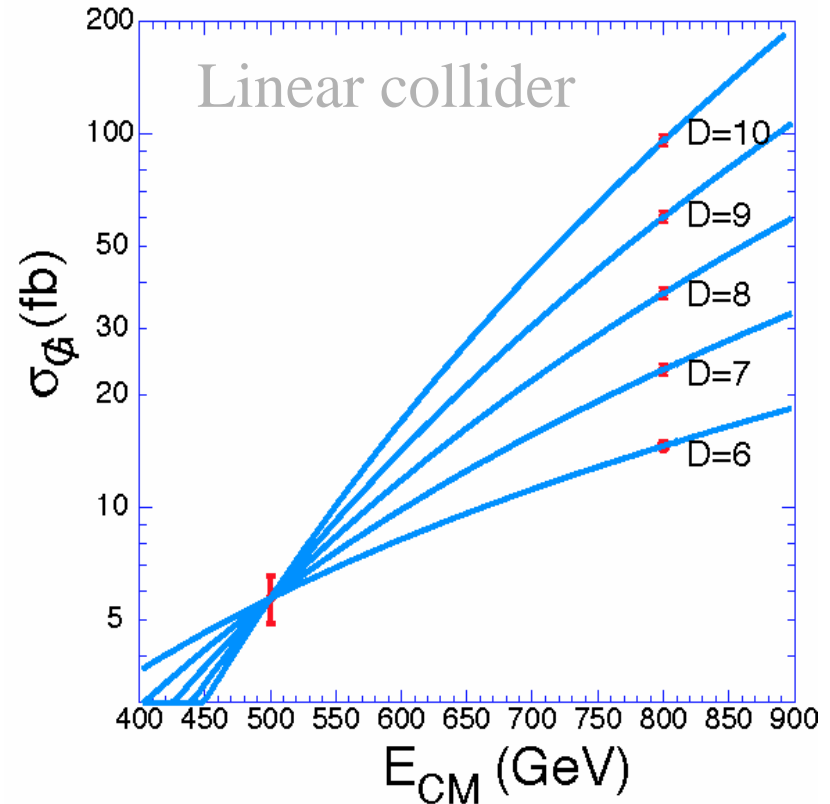

Supersymmetry

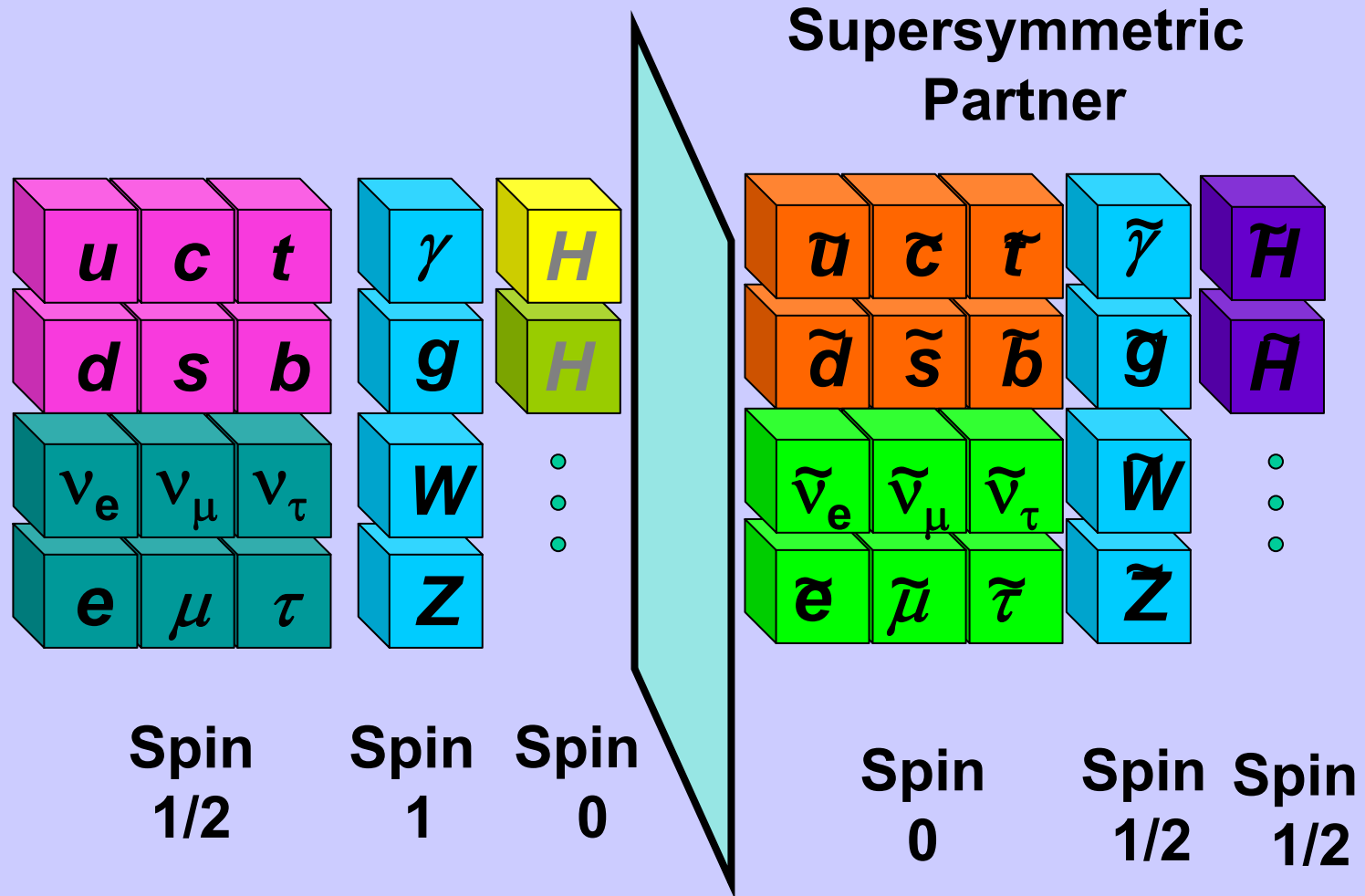

Parameters for the ILC

- E_{cm} adjustable from 200 – 500 GeV
- Luminosity $\rightarrow \int L dt = 500 \text{ fb}^{-1}$ in 4 years
- Ability to scan between 200 and 500 GeV
- Energy stability and precision below 0.1%
- Electron polarization of at least 80%
- **The machine must be upgradeable to 1 TeV**

Circular or Linear Collider?

- Circular Machine**

- $\Delta E \sim (E^4 / m^4 R)$

- $\text{Cost} \sim a R + b \Delta E$

- $\sim a R + b (E^4 / m^4 R)$

- **Optimization : $R \sim E^2 \Rightarrow \text{Cost} \sim c E^2$**

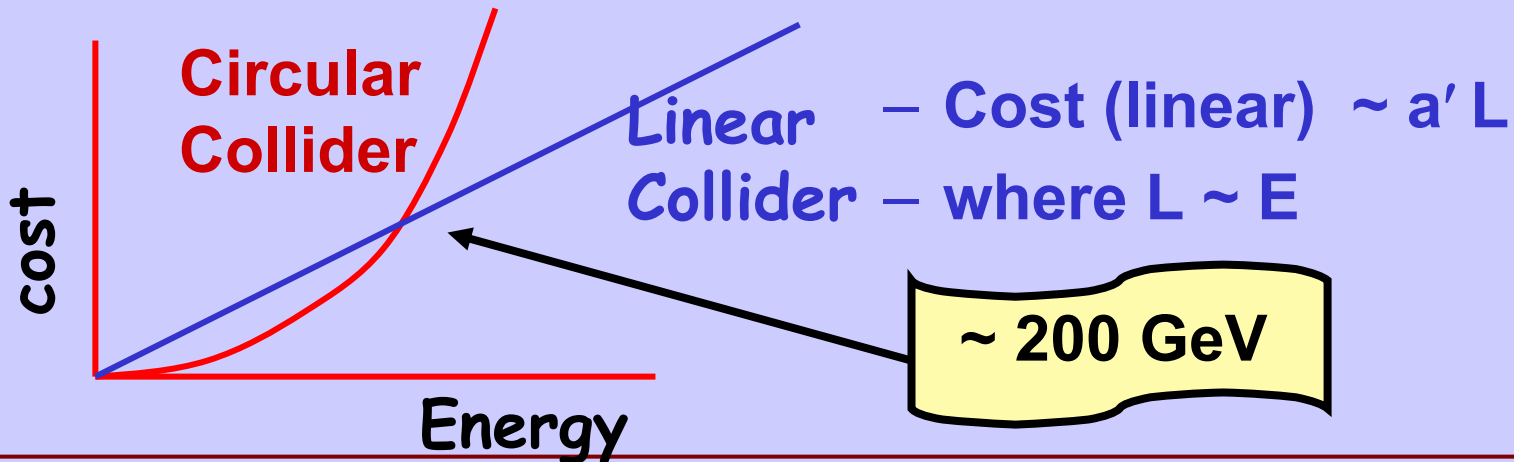
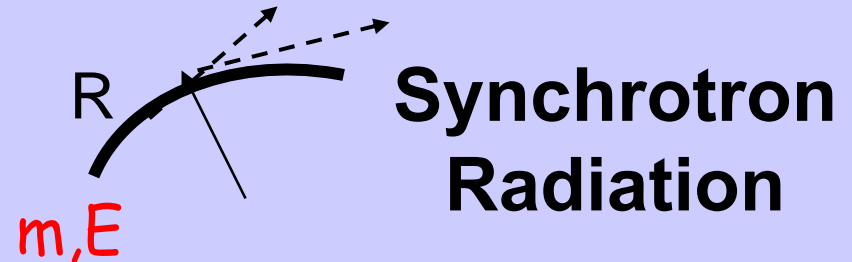

Luminosity & Beam Size

$$L = \frac{n_b N^2 f_{rep}}{2\pi \Sigma_x \Sigma_y} H_D$$

- $f_{rep} * n_b$ tends to be low in a linear collider

	L	f_{rep} [Hz]	n_b	N [10^{10}]	σ_x [μm]	σ_y [μm]
ILC	2×10^{34}	5	3000	2	0.5	0.005
SLC	2×10^{30}	120	1	4	1.5	0.5
LEP2	5×10^{31}	10,000	8	30	240	4
PEP-II	1×10^{34}	140,000	1700	6	155	4

- The beam-beam tune shift limit is much looser in a linear collider than a storage rings \rightarrow achieve luminosity with spot size and bunch charge
 - Small spots mean small emittances and small betas:
 $\sigma_x = \text{sqrt}(\beta_x \varepsilon_x)$

Achieving High Luminosity

- Low emittance machine optics
- Contain emittance growth
- Squeeze the beam as small as possible

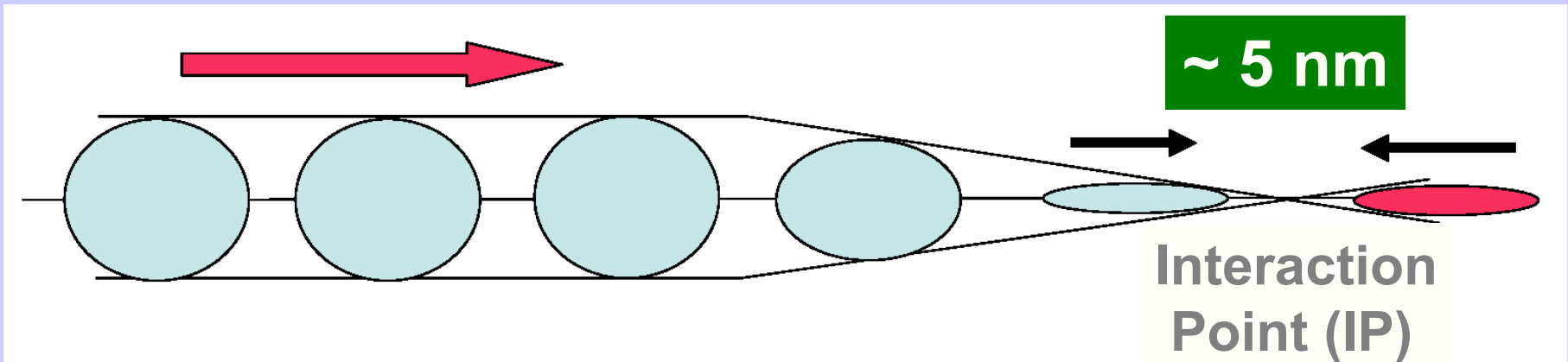

Designing a Linear Collider

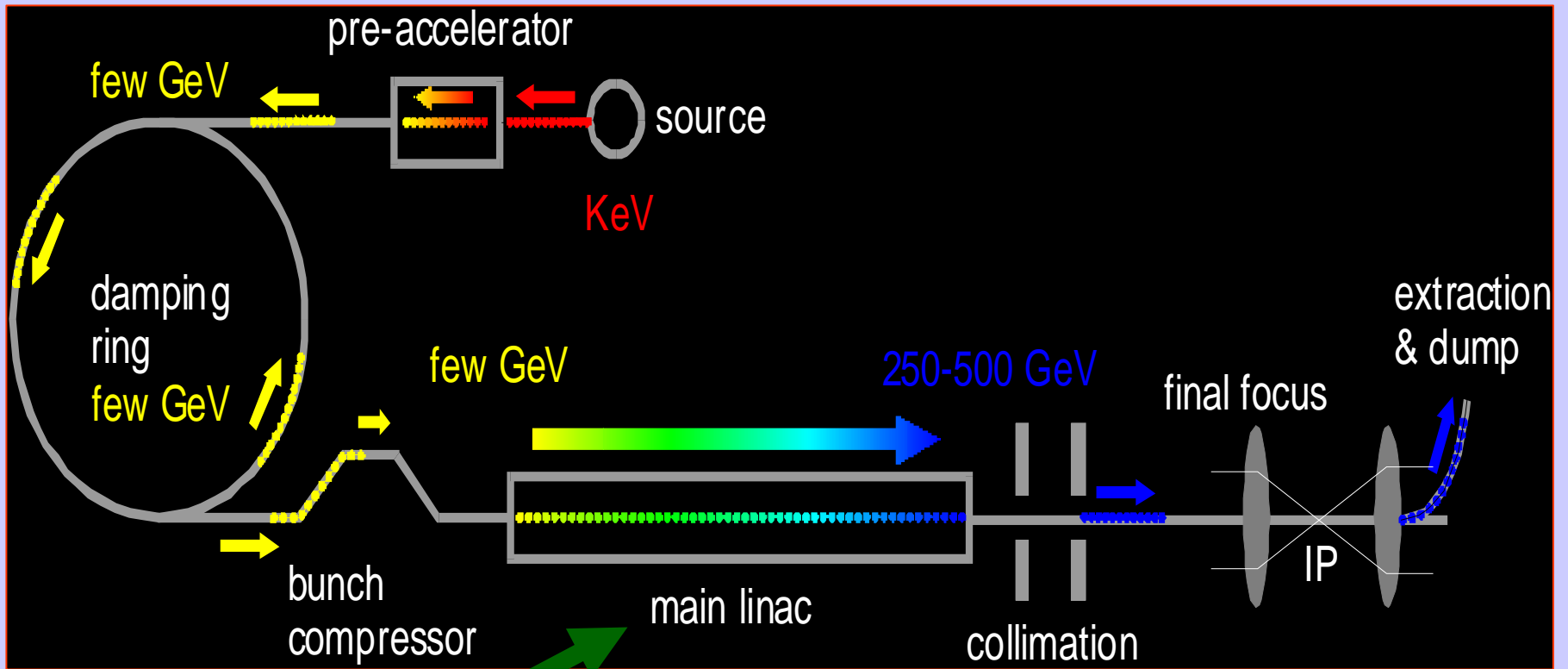

Superconducting RF
Main Linac

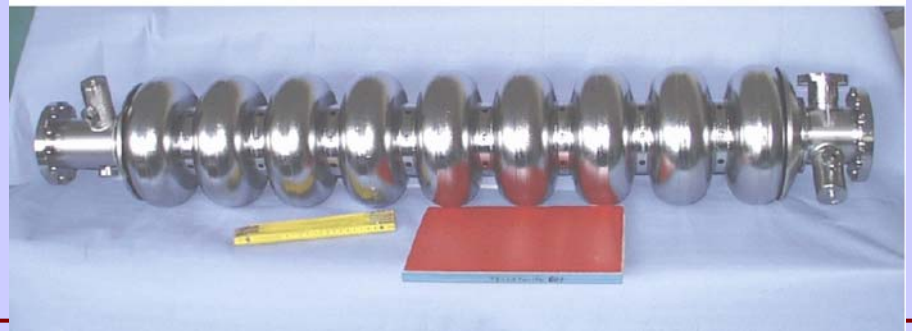

Parametric Approach

- A working space - optimize machine for cost/performance



		min		nominal		max	
Bunch charge	N	1	-	2	-	2	$\times 10^{10}$
Number of bunches	n_b	1330	-	2820	-	5640	
Linac bunch interval	t_b	154	-	308	-	461	ns
Bunch length	σ_z	150	-	300	-	500	μm
Vert. emit.	$\gamma\epsilon_y^+$	0.03	-	0.04	-	0.08	mm-mrad
IP beta (500GeV)	β_x^+	10	-	21	-	21	mm
	β_y^+	0.2	-	0.4	-	0.4	mm
IP beta (1TeV)	β_x^+	10	-	30	-	30	mm
	β_y^+	0.2	-	0.3	-	0.6	mm

The Key Decisions

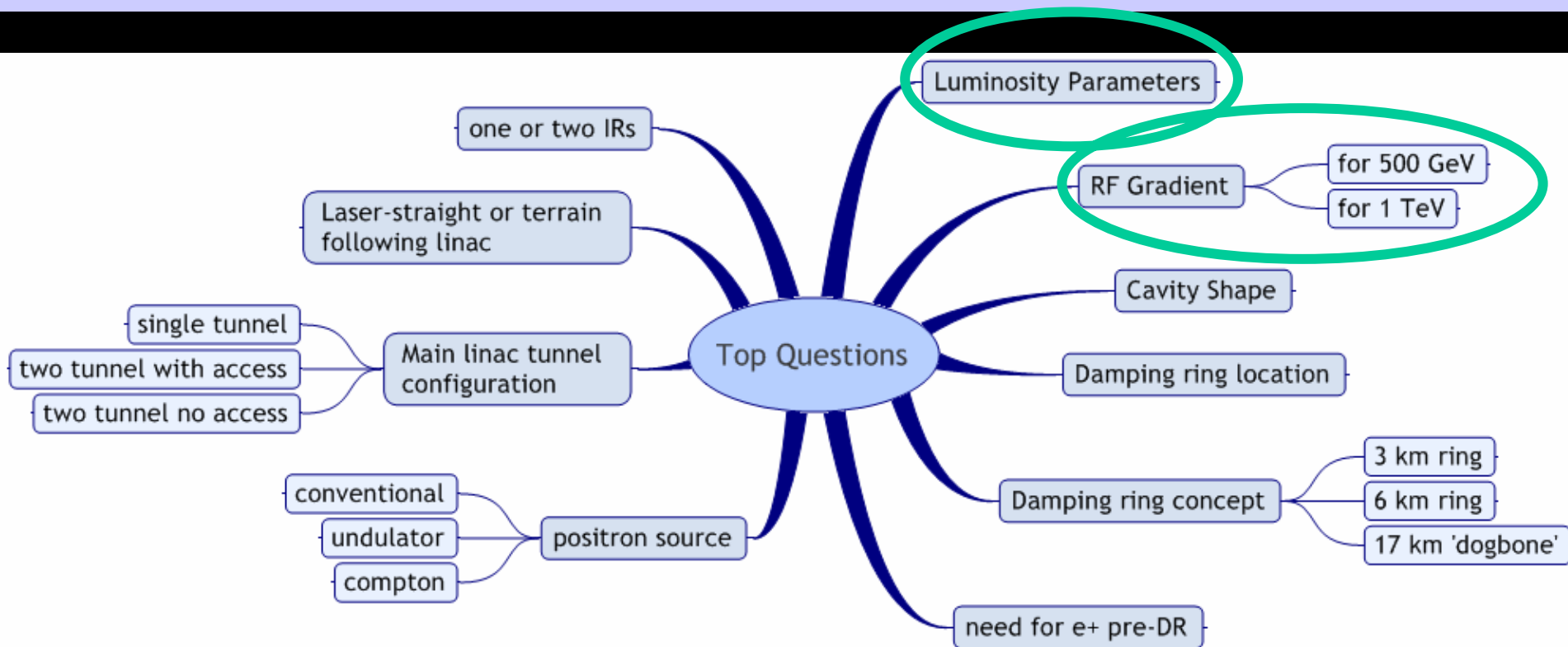

Critical choices: luminosity parameters & gradient

Making Choices - The Tradeoffs

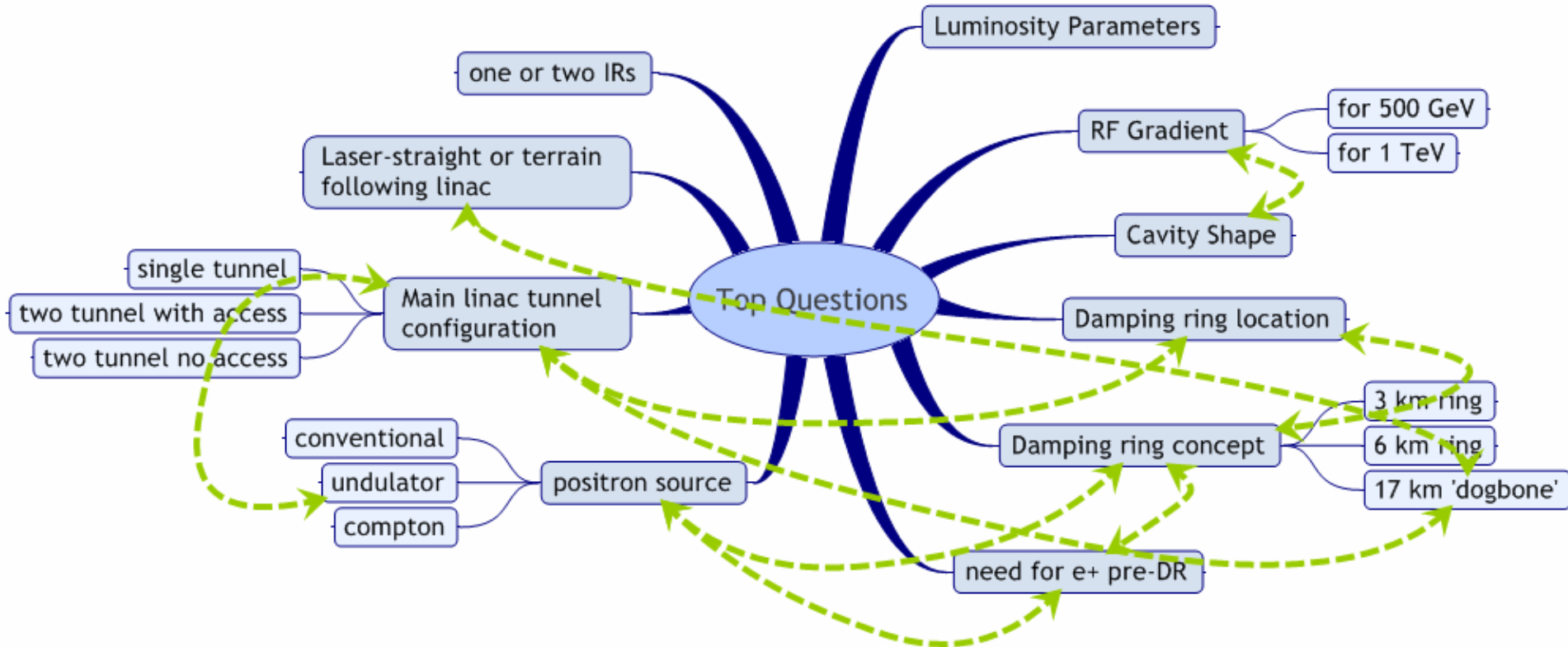

Many decisions are interrelated and require input from several WG/GG groups

The Baseline Machine (500GeV)

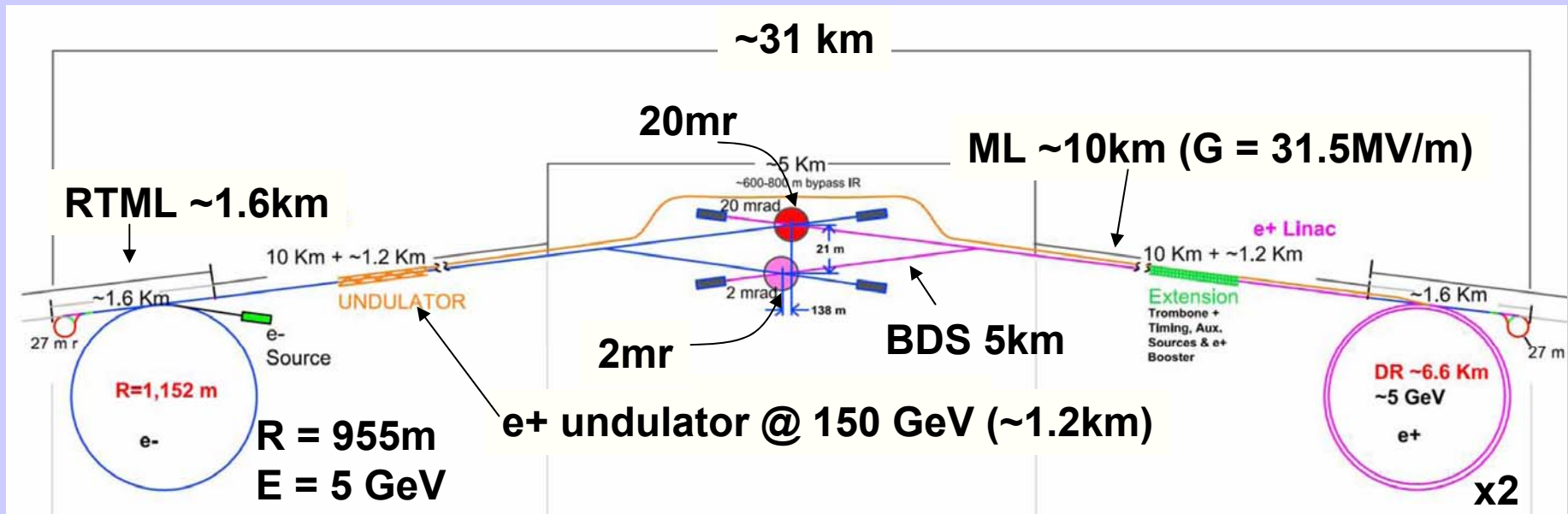

not to scale

Linear Collider Facility

Main Research Center

Particle Detector

~30 km long tunnel

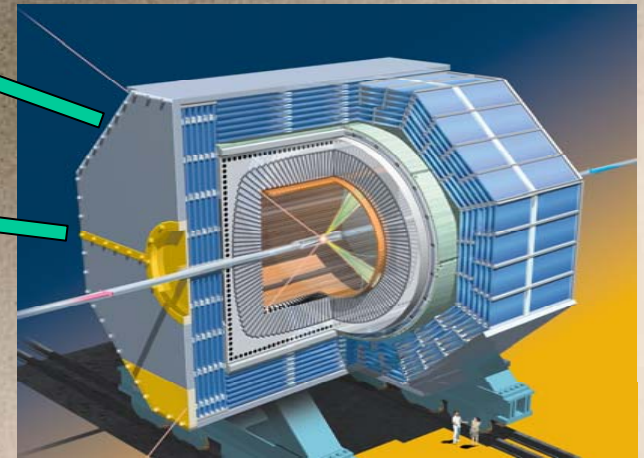

Two tunnels

- accelerator units
- other for services - RF power

Superconducting RF Cavities

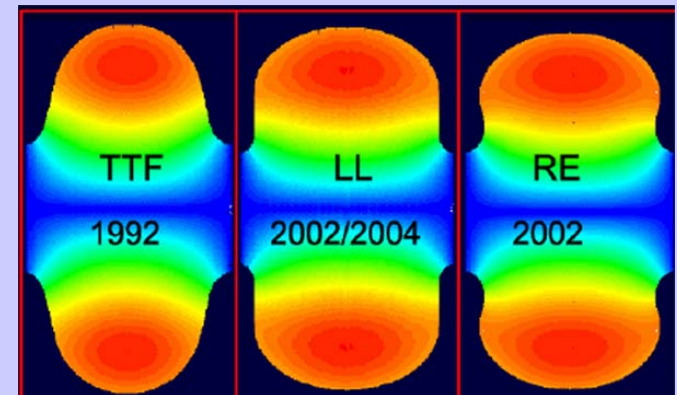

**High Gradient Accelerator
35 MV/meter -- 40 km linear collider**

Gradient

single-cell measurements (in nine-cell cavities)

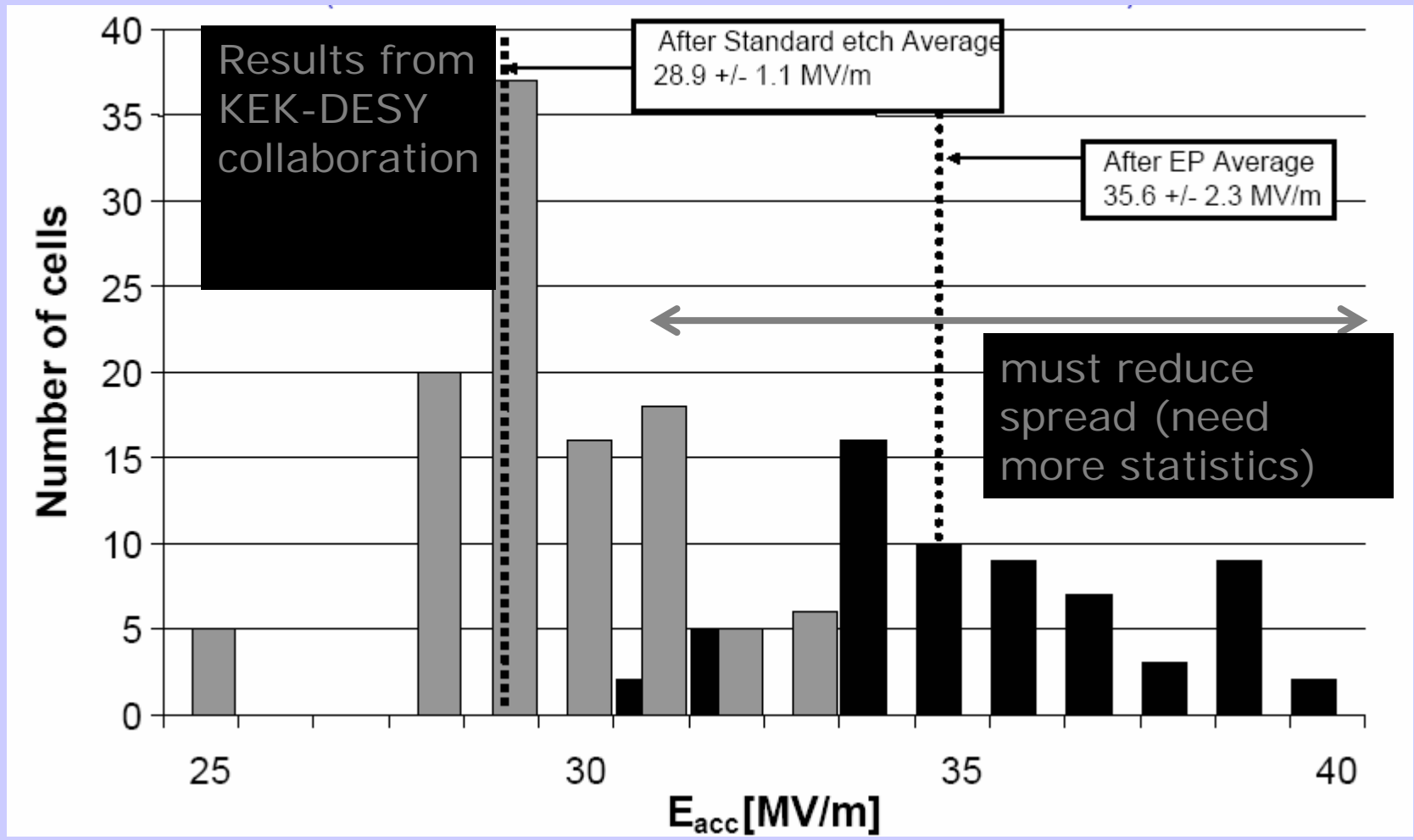

Baseline Gradient

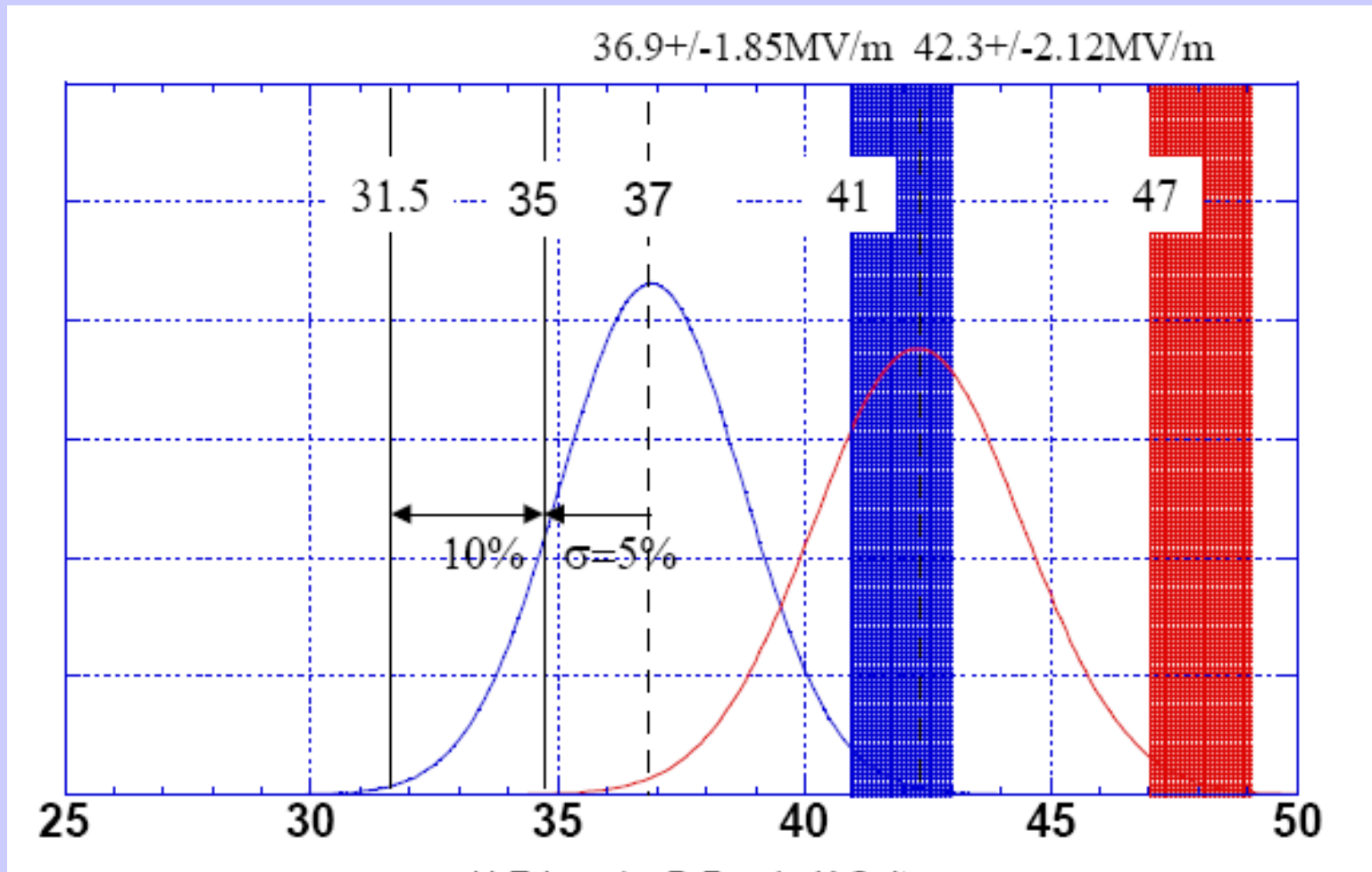

Baseline Features – Electron Source

- **Electron Source – Conventional Source using a DC** ----- Titanium-sapphire laser emits 2-ns pulses that knock out electrons; electric field focuses each bunch into a 250-meter-long linear accelerator that accelerates up to 5 GeV

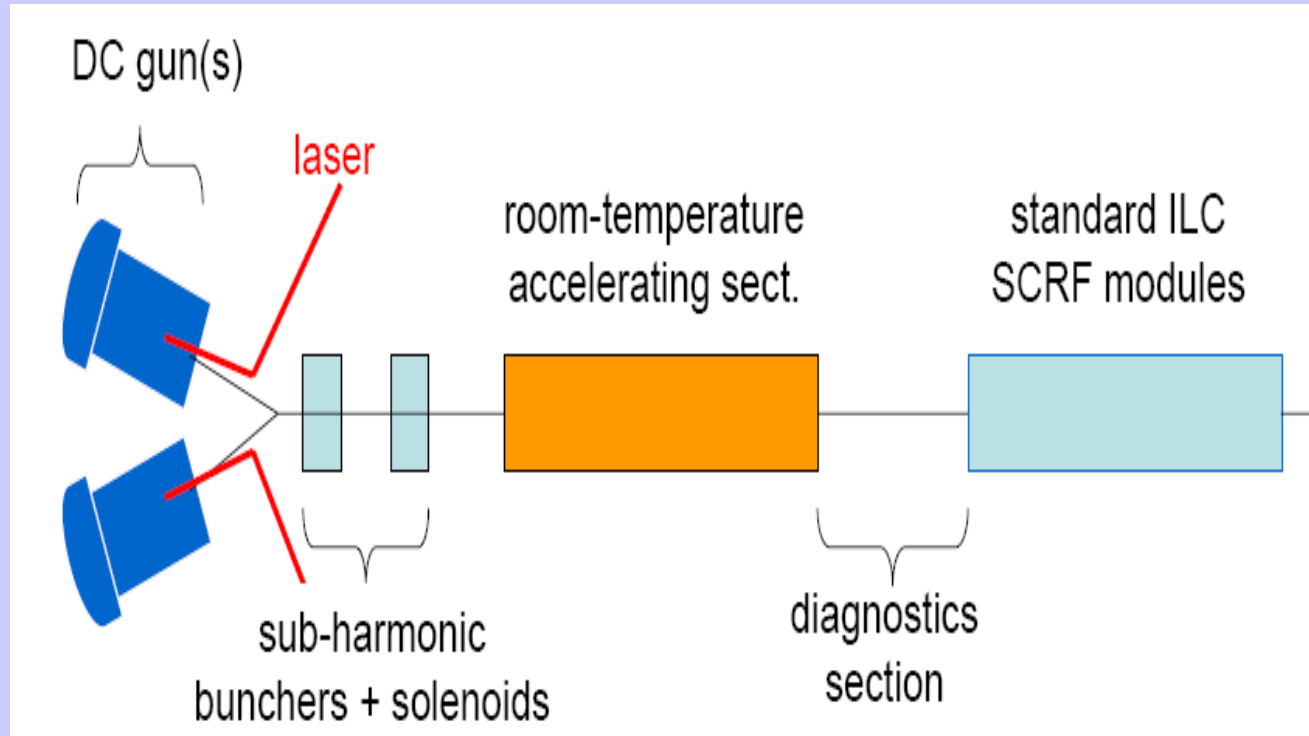

Baseline Features – Positron Source

- **Positron Source – Helical Undulator with Polarized beams** – 150 GeV electron beam goes through a 200m undulator ing making photons that hit a 0.5 rl titanium alloy target to produce positrons. The positrons are accelerated to 5-GeV accelerator before injecting into positron damping ring.

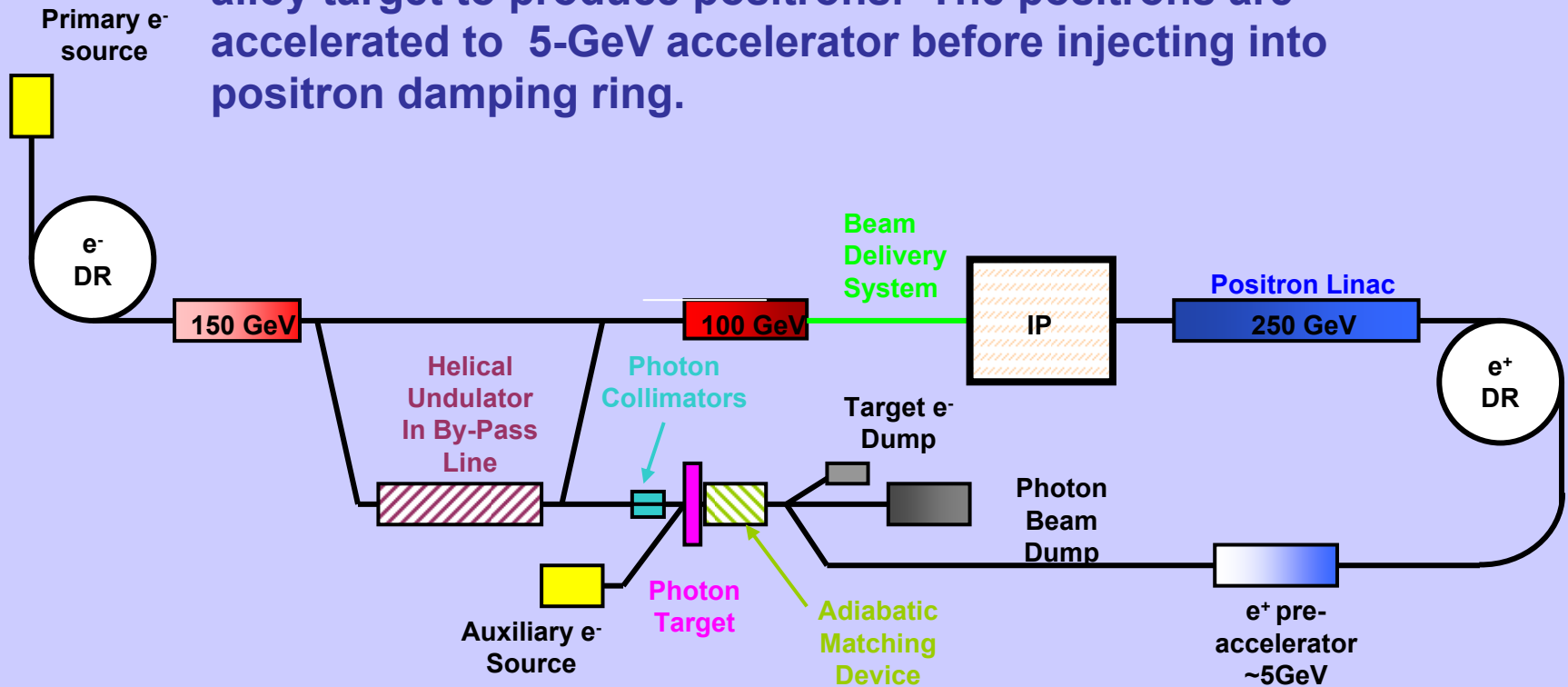

6 Km Damping Ring

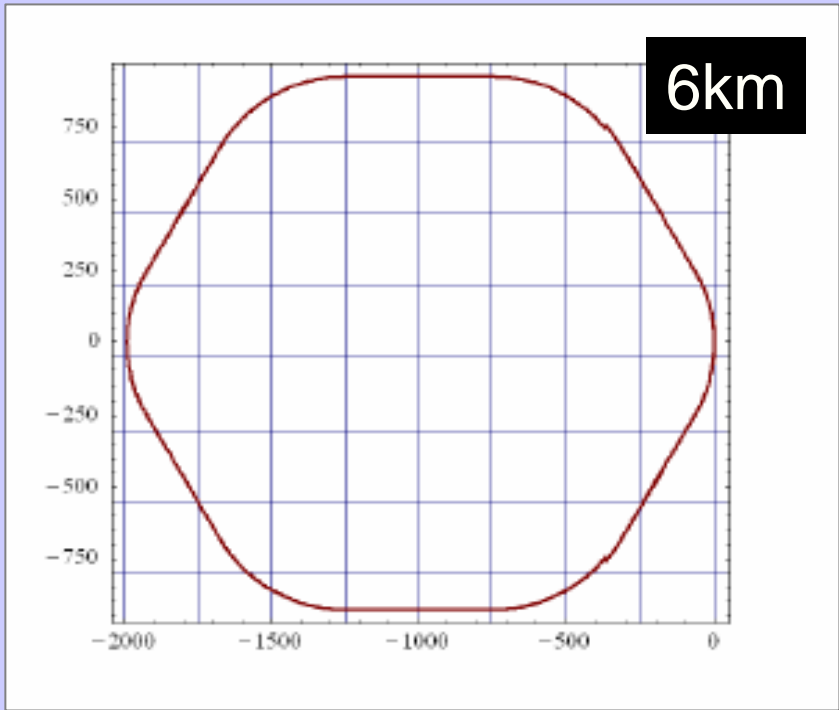

Requires Fast Kicker 5 nsec rise and 30 nsec fall time

The damping rings have more accelerator physics than the rest of the collider

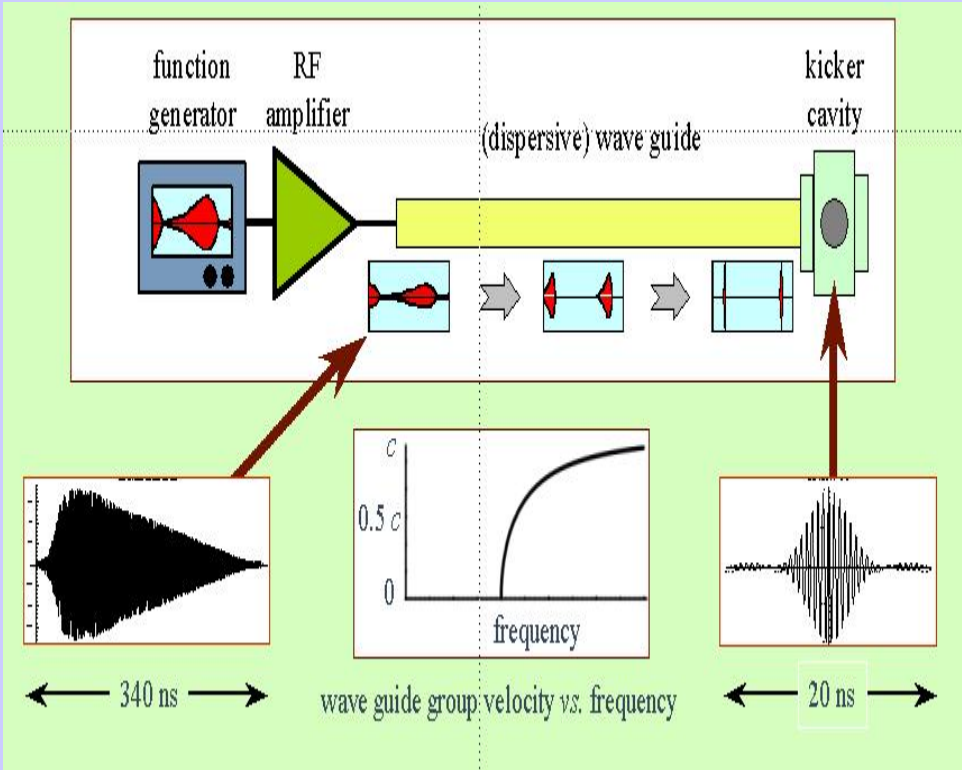

Beam Delivery System

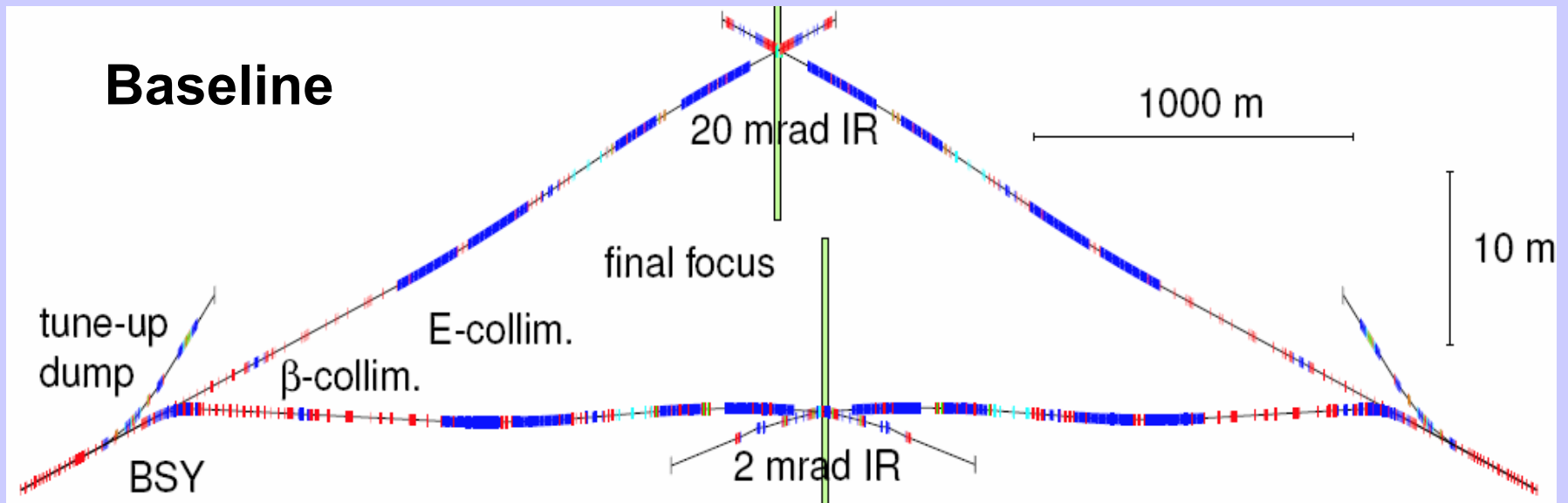

- **Requirements:**

- Focus beams down to very small spot sizes
- Collect out-going disrupted beam and transport to the dump
- Collimate the incoming beams to limit beam halo
- Provide diagnostics and optimize the system and determine the luminosity spectrum for the detector
- Switch between IPs

Detectors for the ILC

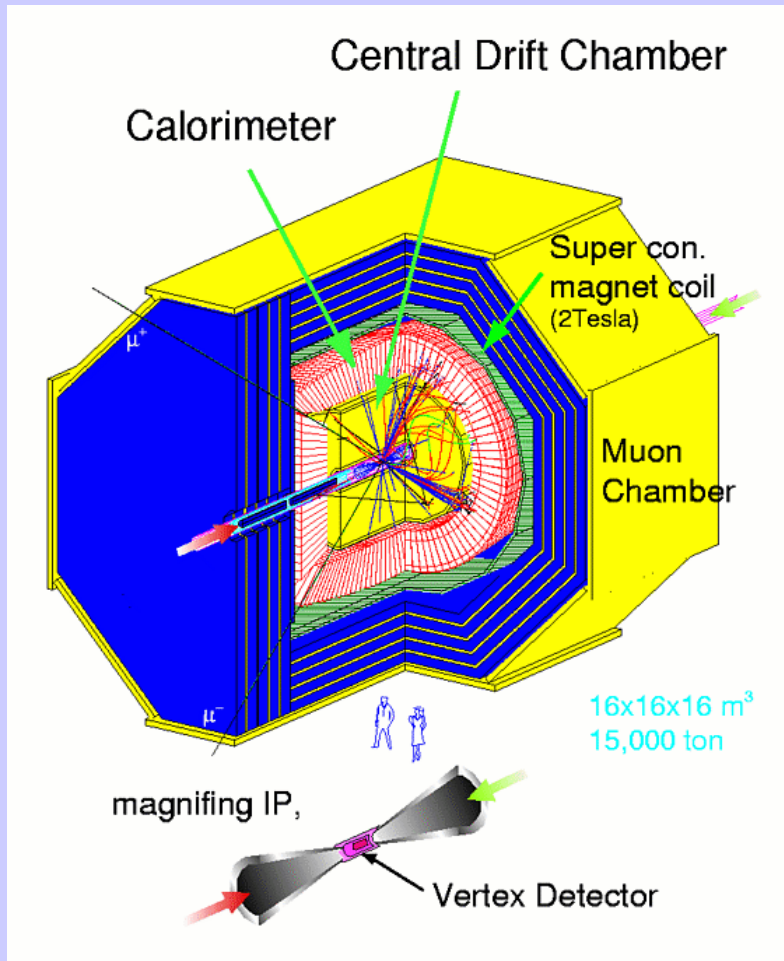

- **Large Scale 4π detectors with solenoidal magnetic fields.**
- **In order to take full advantage of the ILC ability to reconstruct, need to improve resolutions, tracking, etc by factor of two or three**
- **New techniques in calorimetry, granularity of readout etc being developed**

Cost vs Performance

- We obtained our first ILC costing in July
- We are validating those costs and studying areas where different costing disagree
- We are studying areas where costs appear larger than expected for requirements, value engineering, etc.
- Our aim is to produce a reference design, which has taken into account major cost vs performance optimization – examples
 - 2mr x 20 mr compared to 14mr x 14 mr
 - One positron damping ring
 - Optimizing size of tunnels
 - Position of damping ring

Final Remarks

- **Design Status and Plans**
 - **Baseline was determined and documented at end of 2005**
 - **Plan to complete reference design / cost by the end of 2006**
 - **Technical design by end of 2009**
- **R & D Program**
 - **Support baseline: demonstrations; optimize cost / performance; industrialization**
 - **Develop improvements to baseline – cavities; high power RF**
- **Overall Strategy**
 - **Be ready for an informed decision by 2010**
 - **Siting; International Management; LHC results; CLIC feasibility etc**