

LASER INTERFEROMETER GRAVITATIONAL WAVE OBSERVATORY
- LIGO -
CALIFORNIA INSTITUTE OF TECHNOLOGY
MASSACHUSETTS INSTITUTE OF TECHNOLOGY

Document Type LIGO-T960009-00 - Cxx 5/28/96
LIGO Data Acquisition System Design Requirements
R. Bork

Distribution of this draft:

This is an internal working note
of the LIGO Project.

California Institute of Technology
LIGO Project - MS 51-33
Pasadena CA 91125
Phone (818) 395-2129
Fax (818) 304-9834
E-mail: info@ligo.caltech.edu

Massachusetts Institute of Technology
LIGO Project - MS 20B-145
Cambridge, MA 01239
Phone (617) 253-4824
Fax (617) 253-7014
E-mail: info@ligo.mit.edu

WWW: <http://www.ligo.caltech.edu/>

1 Introduction	5
1.1. Purpose	5
1.2. Scope	5
1.3. Definitions	5
1.4. Acronyms	6
1.5. Applicable Documents	6
2 General description	6
2.1. Specification Tree	6
2.2. Product Perspective	8
2.3. Product Functions	8
2.4. Interfaces	9
2.5. Functional Description	10
2.6. General Constraints	12
2.6.1. Standards	12
2.6.2. Availability	12
2.6.3. Data Compression	12
2.7. Assumptions and Dependencies	12
2.7.1. Data Acquisition Channels and Rates	12
2.7.2. Data Source	14
2.7.3. Data Distribution	14
3 Requirements	15
3.1. Characteristics	15
3.1.1. Performance Characteristics	15
3.1.1.1 Overall System	15
3.1.1.1.1 Operation	15
3.1.1.1.1.1 Normal	15
3.1.1.1.1.2 Reconfiguration	15
3.1.1.1.1.3 Power Up	15
3.1.1.1.1.4 Power Loss	15
3.1.1.1.2 User Interfaces	15
3.1.1.1.2.1 Off-line Configuration Tools	16
3.1.1.1.2.2 Runtime Operator Interfaces	16
3.1.1.1.2.3 Application Programmer Interfaces	16
3.1.1.1.2.4 Spy Functions	16
3.1.1.1.3 Data Compression	16
3.1.1.2 Data Collection Units (DCU)	16
3.1.1.2.1 Interfaces	17
3.1.1.2.2 Overall Data Capacity	17
3.1.1.2.3 Analog to Digital Conversion	17

3.1.1.2.3.1	ADC Requirements	17
3.1.1.2.3.2	Sampling Rate	18
3.1.1.2.3.3	Timing	18
3.1.1.2.4	Network Data	18
3.1.1.2.4.1	Dynamic Control and Monitoring Information	18
3.1.1.2.4.2	Static/Infrequent Data	18
3.1.1.2.5	Diagnostics	18
3.1.1.2.6	Operation	18
3.1.1.2.6.1	Normal	18
3.1.1.2.6.2	Reconfiguration	19
3.1.1.2.6.3	Power Up	19
3.1.1.2.6.4	Fault	19
3.1.1.2.6.5	Fault Recovery	19
3.1.1.2.7	Runtime User Interface	19
3.1.1.2.8	Configuration	19
3.1.1.3	Framebuilder	20
3.1.1.3.1	Data Assembly	20
3.1.1.3.1.1	General Frame Characteristics	21
3.1.1.3.1.2	Complete Data Frames (CDF)	21
3.1.1.3.1.3	Limited Data Frames (LDF)	21
3.1.1.3.1.4	Special Purpose Frames (SPF)	22
3.1.1.3.1.5	Diagnostic Data Frames (DDF)	22
3.1.1.3.1.6	Data Filtering	22
3.1.1.3.2	Configuration Tools	22
3.1.1.3.3	Operation	22
3.1.1.3.3.1	Normal	22
3.1.1.3.3.2	Reconfiguration	22
3.1.1.3.4	Diagnostics	23
3.1.1.4	Long Term Storage Unit (LTSU)	23
3.1.1.4.1	General Requirements	23
3.1.1.4.2	Media Header Information	23
3.1.1.4.2.1	Media Preambles	23
3.1.1.4.2.2	Media Summary	24
3.1.1.4.3	Operation	24
3.1.1.4.3.1	Normal	24
3.1.1.4.3.2	Reconfiguration	24
3.1.1.4.3.3	Power Up	24
3.1.1.4.3.4	Fault	24
3.1.1.4.4	Configuration	24
3.1.1.4.5	Diagnostics	25
3.1.1.4.6	Runtime User Interface	26
3.1.1.4.6.1	LTSU Control	26
3.1.1.4.6.2	LTSU Status Information	26
3.1.1.5	Short Term Storage Units	26
3.1.1.5.1	General Requirements	27
3.1.1.5.1.1	Storage Capacity	27

3.1.1.5.1.2	Storage Rates	27
3.1.1.5.1.3	Data Retrieval	27
3.1.1.5.2	Configuration	28
3.1.1.5.3	Diagnostics	28
3.1.1.5.4	Runtime User Interface	28
3.1.1.6	Real-time Data Distribution Unit (RDDU)	28
3.1.1.6.1	General Requirements	28
3.1.1.6.2	Interface	29
3.1.1.6.3	Diagnostics	29
3.1.1.7	On-Line Database	29
3.1.1.7.1	Access	29
3.1.1.7.2	Data	29
3.1.1.7.3	Capacity	30
3.1.2.	Physical Characteristics	31
3.1.2.1	Electronic equipment housings	31
3.1.2.2	Weight Limits	31
3.1.3.	Interface Definitions	31
3.1.3.1	Interfaces to other LIGO detector subsystems	31
3.1.3.1.1	Mechanical Interfaces	31
3.1.3.1.2	Electrical Interfaces	31
3.1.3.1.2.1	Direct Analog Signal Connection	31
3.1.3.1.2.2	Network Connections	31
3.1.3.1.2.3	Electrical Power	31
3.1.3.1.3	Optical Interfaces	31
3.1.3.1.4	Stay Clear Zones	32
3.1.3.2	Interfaces external to LIGO detector subsystems	32
3.1.3.2.1	Mechanical Interfaces	32
3.1.3.2.2	Electrical Interfaces	32
3.1.3.2.3	Stay Clear Zones	32
3.1.4.	Reliability	32
3.1.5.	Maintainability	32
3.1.6.	Environmental Conditions	32
3.1.6.1	Natural Environment	32
3.1.6.1.1	Temperature and Humidity	32
3.1.6.1.2	Atmospheric Pressure	32
3.1.6.2	Induced Environment	32
3.1.6.2.1	Vibrations	32
3.1.6.2.2	Acoustic Noise	33
3.1.6.2.3	Electromagnetic Radiation	33
3.1.7.	Transportability	33
3.2.	Design and Construction	33
3.2.1.	Materials and Processes	33
3.2.1.1	Finishes	33
3.2.2.	Component Naming	33
3.2.3.	Workmanship	33
3.2.4.	Interchangeability	34

3.2.5. Safety	34
3.2.6. Human Engineering	34
3.3. Documentation	34
3.3.1. Specifications	34
3.3.2. Design Documents	34
3.3.3. Engineering Drawings and Associated Lists	34
3.3.4. Technical Manuals and Procedures	34
3.3.4.1 Procedures	34
3.3.4.2 Manuals	35
3.3.5. Documentation Numbering	35
3.3.6. Test Plans and Procedures	35
3.4. Logistics	35
3.5. Precedence	35
3.6. Qualification	35
4 Quality Assurance (QA) Provisions	35
4.1. General	35
4.1.1. Responsibility for Tests	36
4.1.2. Special Tests	36
4.1.3. Configuration Management	36
4.2. Quality Conformance Inspections	36
4.2.1. Inspections	36
4.2.2. Analysis	36
4.2.3. Demonstration	36
4.2.4. Similarity	36
4.2.5. Test	37
5 Preparation For Delivery	37
5.1. Preparation	37
5.2. Packaging	37
5.3. Marking	37
6 Notes	37

1 INTRODUCTION

1.1. Purpose

The purpose of the LIGO Data Acquisition System (DAQS) is to acquire, format, store and distribute the various LIGO data which is necessary to:

- Detect and analyze gravity waves.
- Characterize and diagnose LIGO interferometer performance.

1.2. Scope

A LIGO DAQS is to be developed which meets the requirements set forth in this document. The DAQS shall provide the facilities to:

- Acquire LIGO data from various LIGO control and monitoring systems, either via direct analog connections or network connections.
- Format the acquired data into defined data blocks, known as frames.
- Store data frames to long and short term storage media.
- Provide data on request via computer networks from either its short term storage devices or “live” data immediately after it is framed.
- Provide operator views into the acquisition processes.
- Configure the DAQS and its acquisition, storage and distribution processes.

Specifically not considered to be within the scope of the DAQS are:

- Data networks for the distribution of DAQS data to other systems (networks are to be provided by CDS under control and monitoring and by LIGO site general computing).
- Mass storage units, processors and software necessary to read and distribute data from tapes written by the DAQS (considered to be the responsibility of data analysis systems and/or LIGO general computing).
- Tape duplication and distribution facilities.

1.3. Definitions

Configuration/Reconfiguration: In the context of this document, configuration/reconfiguration to the DAQS is defined as software configuration changes which change data frame, rates, distribution, etc. Configuration/reconfiguration does not apply to hardware changes to the system.

On-Line: Data is considered to be “on-line” if it is readily available to clients via CDS networks, either from short term storage or directly accessed from DAQS memory.

On-Line Analysis Systems: systems which analyze DAQS on-line data for gravity wave information in real (pseudo-real) time at each site.

1.4. Acronyms

- AI Analog Input
- CDF Complete Data Frame
- CDS Control and Data System
- DAQS Data AcQuisition System
- DCU Data Collection Unit
- DDF Diagnostic Data Frame
- GUI Graphical User Interface
- IFO Interferometer
- LDF Limited Data Frame
- LIGO Laser Interferometer Gravitational Wave Observatory
- LTSU Long Term Storage Unit
- MTBF Mean Time Before Failure
- MTTR Mean Time To Repair
- NFS Network File Services
- RDDU Real-time Data Distribution Unit
- RH Relative Humidity
- SPF Special Purpose Frame
- STSU Short Term Storage Unit
- TBD To Be Determined

1.5. Applicable Documents

T950054-C Global CDS Control and Monitoring Design Requirements Document

T950120-C Global CDS Control and Monitoring Conceptual Design

M950046-F LIGO Project System Safety Management Plan

L950003 LIGO Document Numbering System

T950111 LIGO Naming Conventions

E950090 Detector - Civil Construction ICD

T9960083-A Derivation of CDS Rack Acoustic Noise Specifications

2 GENERAL DESCRIPTION

2.1. Specification Tree

This document is part of an overall LIGO detector requirement specification tree. This particular document is highlighted in the following figure.

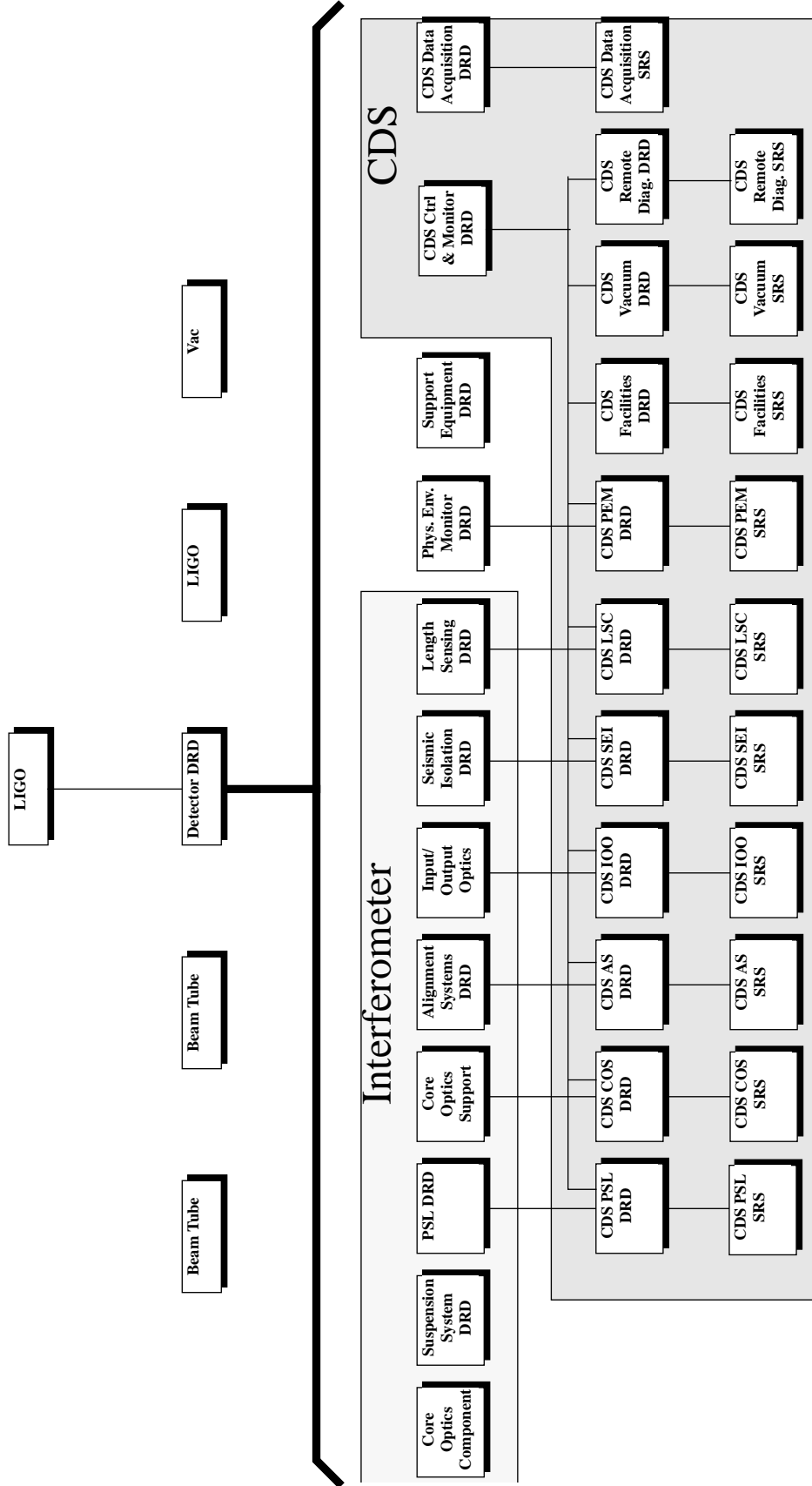

2.2. Product Perspective

The DAQ is an integral part of the LIGO CDS. The LIGO CDS is divided into three primary functional units, as shown in Figure 1: CDS Functional Units. These are:

- **Control & Monitoring:** Provides for the control and monitoring of LIGO interferometers and other scientific instruments, along with the LIGO vacuum systems. It also provides the basic infrastructure for the CDS, which includes such functions as networks, timing, and operator stations.
- **Data Acquisition:** Provides for the acquisition of all LIGO data integral to gravitational wave analysis.
- **I/O Diagnostics:** Provides on-line analysis and display processing of data from the control & monitoring and data acquisition systems for the purposes of diagnosing, characterizing and improving interferometer performance.

Once data has been acquired by the DAQS, it must be distributed to data analysis systems. Actual data analysis for the detection and characterization of gravity waves is outside the scope of CDS.

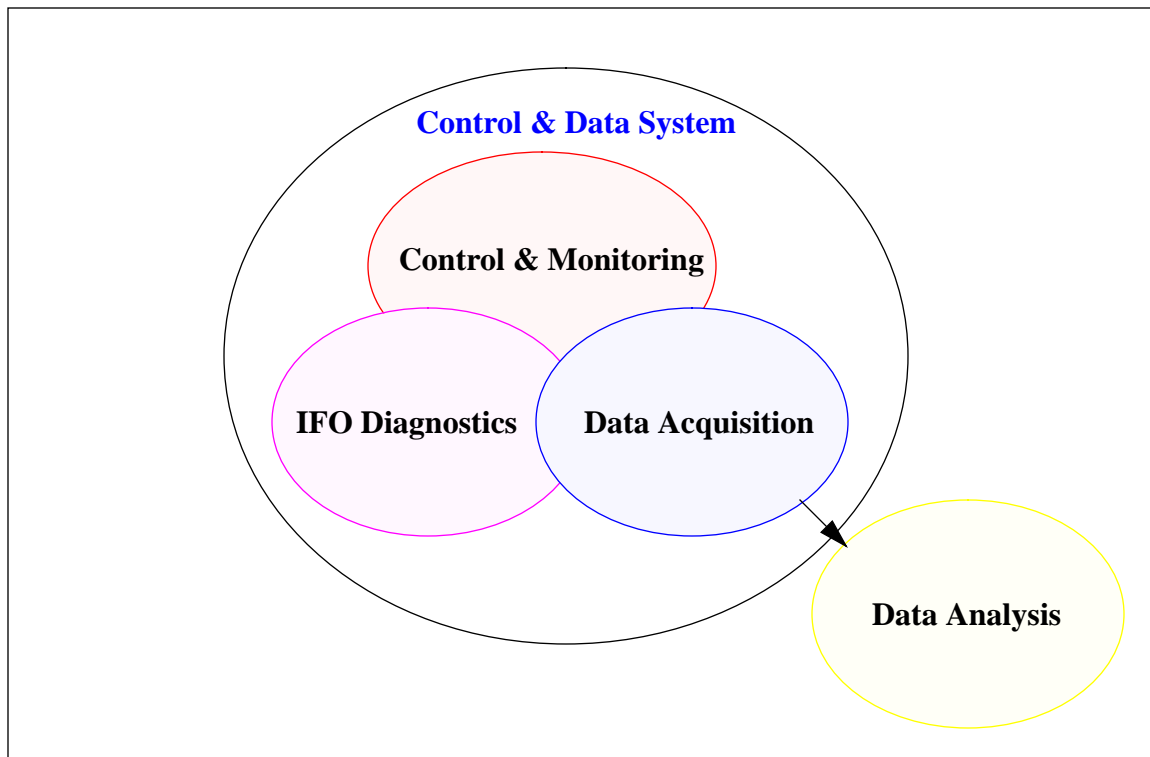

Figure 1: CDS Functional Units

2.3. Product Functions

The primary functions of the DAQS are:

1. Acquire and archive all LIGO data which are necessary for the detection and analysis of gravitational waves.

2. Provide a limited set of data distribution capabilities to on-line and off-line data analysis systems.
3. Provide on-line availability of acquired data to the IFO diagnostics system for IFO performance characterization and analysis.

2.4. Interfaces

Figure 2: DAQS Interfaces depicts the various interfaces to the DAQS. Data to be acquired will be connected either directly as analog signals or be provided via a network connection from the CDS control and monitoring systems. Additional processed information, such as calibration functions and snapshot data, may also be passed to the DAQS for archival by IFO diagnostic and on-line analysis systems.

Once acquired, data from the DAQS must be archived for later off-line analysis and made available on-line to various subsystems for on-line analysis.

The DAQS must also provide interfaces to operator stations and an On-line database for purposes of configuring the DAQS and displaying/storing DAQS configuration information.

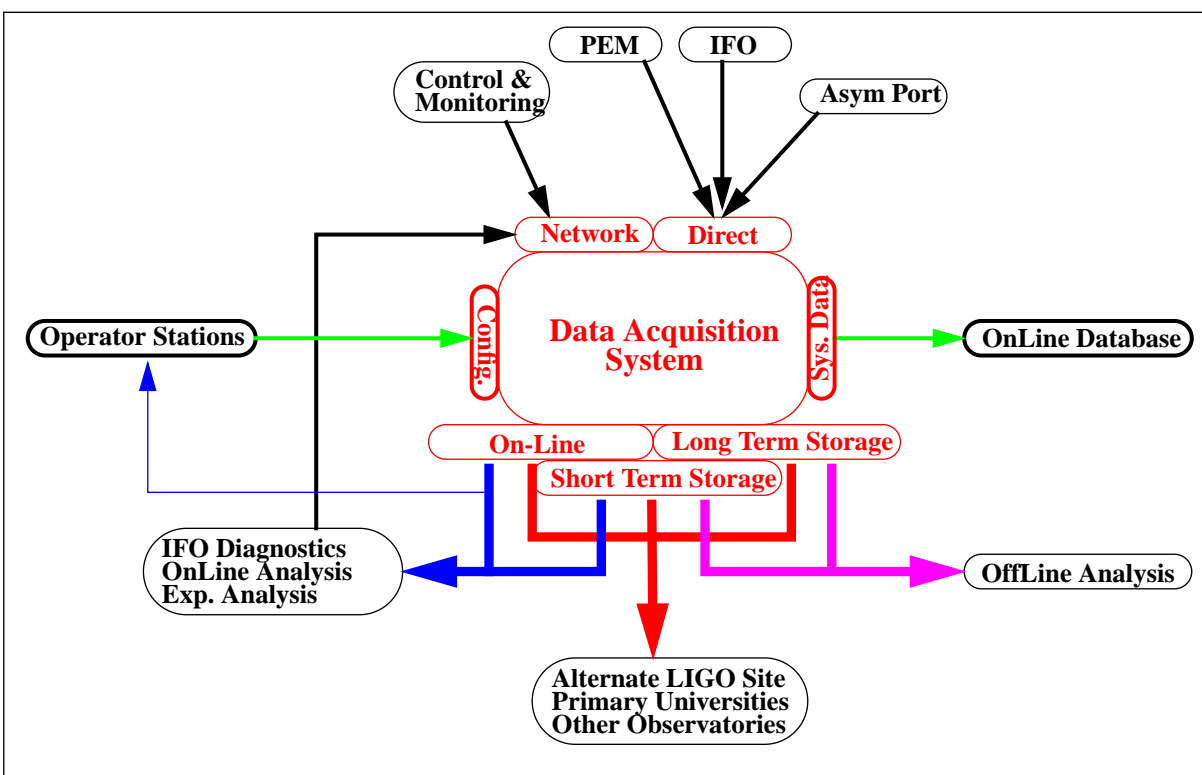

Figure 2: DAQS Interfaces

2.5. Functional Description

To assist in defining the requirements in following sections, the DAQS has been broken down into functional units, along with a concept of data flow through the functional blocks.

The functional units are shown in Figure 3: DAQS Functional Block Diagram and defined as follows:

- Data Collection Unit (DCU): That hardware and software which supplies the function of collecting LIGO data, either via CDS networks or directly through analog connections
- Framebuilder: That hardware and software which provides the capability to assemble data into defined blocks, commonly known as frames.
- Long Term Storage: That hardware and software which provides the capability to archive LIGO data which is to be maintained for long periods of time (months/years)
- DAQS Database: That hardware and software which provides the capability to store and retrieve pre-defined information about the DAQS and its storage media
- Short Term Storage: That hardware and software which provides the capability to store data which is randomly accessible for short periods of time (hours/days)
- Real-Time (RT) Data Distribution: That hardware and software which provides the capability to transmit frame information directly from the framebuilder to on-line analysis and IFO diagnostic systems.

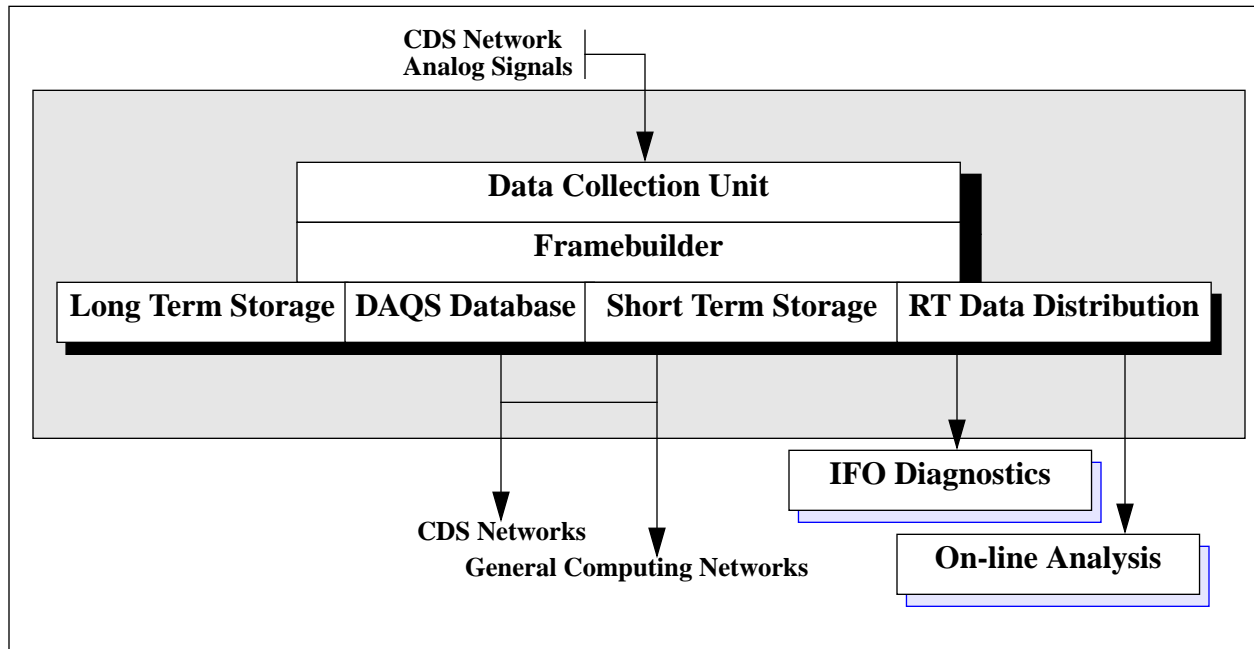

Figure 3: DAQS Functional Block Diagram

Data flow through the DAQS is perceived to be roughly as shown in Figure 4: Data Flow Concept. Note that this is not intended to show or specify exact data structures, but only to give a concept of how data might flow through the system.

- DCU: DCU are configured with information which relates ADC and network data inter-

faces with channel identifiers, sample rates, and additional descriptors. It acquires data in accordance with this configuration information and packages each second's worth of data into a structure, which would include a time stamp and sample rate information.

- **Framebuilder:** A frame consists of a header and data, with the header describing the type of frame it is and the data which is included. At runtime, the DAQS user specifies, by type, the frames which are to be assembled by the framebuilder. The framebuilder then accepts data from the DCU and packages it into the various frame types requested in accordance with the frame type definitions.
- The various DAQS storage units are configured by the users to store frames by type from the framebuilder. For example, a tape drive unit might be configured to store frame type 1 and frame type 3. At runtime, whenever the framebuilder has assembled a frame of type 1 or 3, the DAQS storage unit gets that frame from the framebuilder and stores it to tape. In addition to frames, the storage units also write headers and preambles to each media. The header would include information on the contents of the media, such as time period covered, etc. The preamble would contain operational information for the period covered by the media, such as operating mode of the IFO, time in lock, etc.
- The RDDU receives requests via CDS networks for data from on-line diagnostic and analysis systems. These requests can be for specific frame types or individual/multiple data channels.
- The DAQS database is anticipated to primarily record DAQS configuration information and act as a "card catalog" for the various storage media. It will also store specific frame types, such as those which contain calibration or IFO status information, such that interferometer history data can be maintained for on-line browsing.

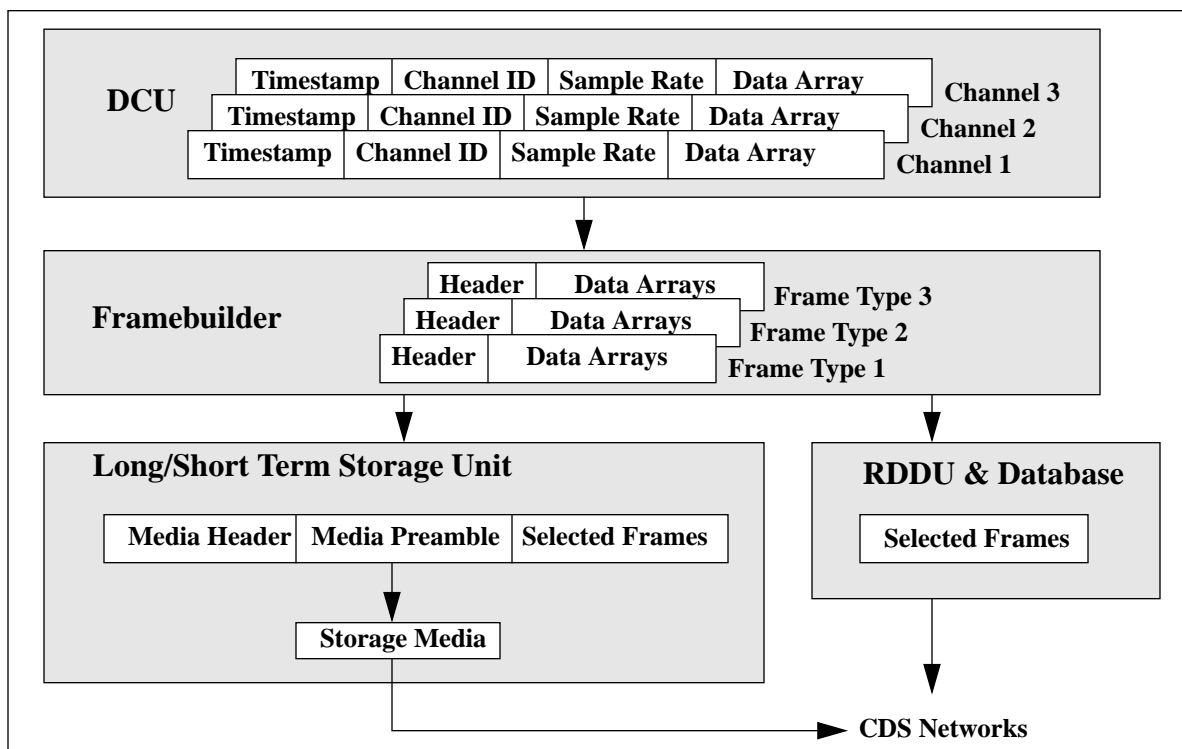

Figure 4: Data Flow Concept

2.6. General Constraints

2.6.1. Standards

Certain standards have been, are being, developed by the CDS group which are documented under the “Control and Monitoring” functions, such as network infrastructures, timing and software. The DAQS shall adhere to these standards, particularly where the DAQS interfaces to other CDS systems.

2.6.2. Availability

LIGO is designed to operate continuously, 24hrs/day, 365 days/year. In initial LIGO interferometers, it is anticipated that as few as three gravitywave events will be detected in the course of a year. Therefore, the DAQS must have a high reliability and availability to meet the operational requirements of LIGO.

2.6.3. Data Compression

In sensitive instruments, such as the LIGO interferometers, data content at the bit level is potentially important in data analysis. Therefore, the DAQS must not employ data compression techniques such that the full resolution of the data acquired and archived can not be recovered.

2.7. Assumptions and Dependencies

2.7.1. Data Acquisition Channels and Rates

Initial data rates and channel count requirements on the DAQS come from early estimations by LIGO staff. The bulk of data will come from the interferometers (IFO), as shown in Table 1: Estimated IFO Data Channels and Rates. Initially, the DAQS must be capable of handling data from two IFO at Hanford and one IFO at Livingston, but must be capable of future expansion.

Along with the IFO, additional data will be acquired from the control and monitoring systems and the Physical Environment Monitoring (PEM) system at each LIGO site. The initial acquisition requirements for these are shown in Table 2: Estimated LIGO PEM/Control & Monitoring Data Channels and Rates.

Finally, Table 3: Estimated Site Data Channels and Rates shows the totals for the LIGO sites when both are initially operational in 2001. It can be seen from this that the DAQS must be capable of acquiring and storing large amounts of data, 19Mbytes/sec or roughly 1.6Tbytes/day.

Table 1: Estimated IFO Data Channels and Rates

<i>System</i>	<i>Number of Channels/Sample Rate</i>				
	<i>2 Hz</i>	<i>256 Hz</i>	<i>2048 Hz</i>	<i>16384 Hz</i>	<i>Total</i>
Sensitive Component Suspension	120	90	30	60	300
Prestabilized Laser	20	10	5	8	43
Mode Cleaner	30	20	10	20	80
Injection Optics	20	15	5	10	50
Interferometer Readout	20	15	0	30	65
Auto Alignment	20	15	0	0	35
Total Acquisition Channels/IFO	230	165	50	128	573
Total Data Rates (KBytes/sec)/IFO	0.9	84.5	204.8	4194.3	4484.5

Table 2: Estimated LIGO PEM/Control & Monitoring Data Channels and Rates

<i>System</i>	<i>Number of Channels / Sample Rate</i>				
	<i>2 Hz</i>	<i>256 Hz</i>	<i>2048 Hz</i>	<i>16384 Hz</i>	<i>Total</i>
Auxillary	0	200	10	30	240
Housekeeping	300	50	20	0	370
Total Channel Counts	300	250	30	30	610
Data Rates (KBytes/sec)	1.2	128	122.9	983.0	1235.1

Table 3: Estimated Site Data Channels and Rates

<i>System</i>	<i>Number of Channels</i>				
	<i>2 Hz</i>	<i>256 Hz</i>	<i>2048 Hz</i>	<i>16384 Hz</i>	<i>Total</i>
Hanford	760	580	130	286	1756

Table 3: Estimated Site Data Channels and Rates

<i>System</i>	<i>Number of Channels</i>				
	<i>2 Hz</i>	<i>256 Hz</i>	<i>2048 Hz</i>	<i>16384 Hz</i>	<i>Total</i>
Livingston	530	415	80	158	1183
Total Channel Counts	1290	995	210	444	2939
Data Rates (KBytes/sec)	5	509.4	860.2	14549.0	15923.6

2.7.2. Data Source

It is assumed that slow data (2Hz) listed in the previous tables comes from control and monitoring systems over the CDS networks. Higher rate (200Hz and higher) data is expected to be directly connected to analog front ends of the DAQS.

2.7.3. Data Distribution

At this time, the LIGO scheme of data analysis has not been fully defined, including what analysis is to be done “on-line” i.e. receives data for and performs analysis in real-time, or what and where off-line analysis is to take place. This document tries to build requirements for a flexible system, but more detailed requirements will come about requiring changes as more information is obtained about analysis systems.

3 REQUIREMENTS

3.1. Characteristics

3.1.1. Performance Characteristics

3.1.1.1 Overall System

3.1.1.1.1 *Operation*

3.1.1.1.1.1 *Normal*

In normal operation, the DAQS shall acquire, archive and distribute data in accordance with its loaded configuration and outside data requests. At a minimum, the system performance shall be such that it can acquire and archive to long term storage the quantity of data prescribed by Table 3: Estimated Site Data Channels and Rates at each site and simultaneously perform those additional functions as prescribed in later sections for each functional unit of the DAQS.

3.1.1.1.1.2 *Reconfiguration*

The system shall be designed in such a manner, that on execution of a request for a new DAQS configuration, data acquisition, archival and distribution are not disrupted i.e. no down time is experienced by the DAQS which causes a time lapse in the data to be acquired.

At all level of the DAQS, the system will first check any new configuration requests for errors, such as the request would cause system faults such as an overload condition.

3.1.1.1.1.3 *Power Up*

On power up of the DAQS or its subsystems following an unscheduled power loss, the DAQS shall automatically return to the state in was in prior to the power outage.

3.1.1.1.1.4 *Power Loss*

The DAQS shall remain operational for a minimum of 15 minutes after loss of facility power to any or all of its components. The DAQS shall monitor the health of site power provided to its components such that that time frame can be used for a “clean”, automatic shutdown of the DAQS. This includes, on power loss,:

- Notification of operations staff, including calculation of time remaining on backup power.
- Prior to complete loss of power, storing DAQS state information and any other data required for automatic resumption of activities after power has been restored.

3.1.1.1.2 *User Interfaces*

Various interfaces must be provided for users of the DAQS. General requirements are given here, with more detail in the various functional unit requirements sections which follow.

3.1.1.1.2.1 Off-line Configuration Tools

The DAQS shall provide off-line configuration tools such that the amount of actual programming required to setup the system for operation is minimized.

3.1.1.1.2.2 Runtime Operator Interfaces

The DAQS shall provide X-windows based user interfaces at operator stations for the on-line monitoring and control of the system.

3.1.1.1.2.3 Application Programmer Interfaces

The DAQS shall provide API in the form of ANSI standard C language functions to allow external, user developed software to access the system.

3.1.1.1.2.4 Spy Functions

The DAQS shall provide various user interface facilities to “spy” or view the various data channels being acquired by the system. These facilities shall include the ability to:

- View user selected data channels at rates to 10Hz in a single value text field
- View time series arrays of operator selected channels (up to 1024 samples, with selectable time frames and data decimation factors) from 1sec frames.

3.1.1.1.3 Data Compression

The DAQS shall not employ any data compression techniques such that the full resolution of any signal acquired by the system is not retained.

3.1.1.2 Data Collection Units (DCU)

For the collection of data, the DAQ shall provide front end interfaces at the various LIGO buildings, including the LVEA and mid and end stations.

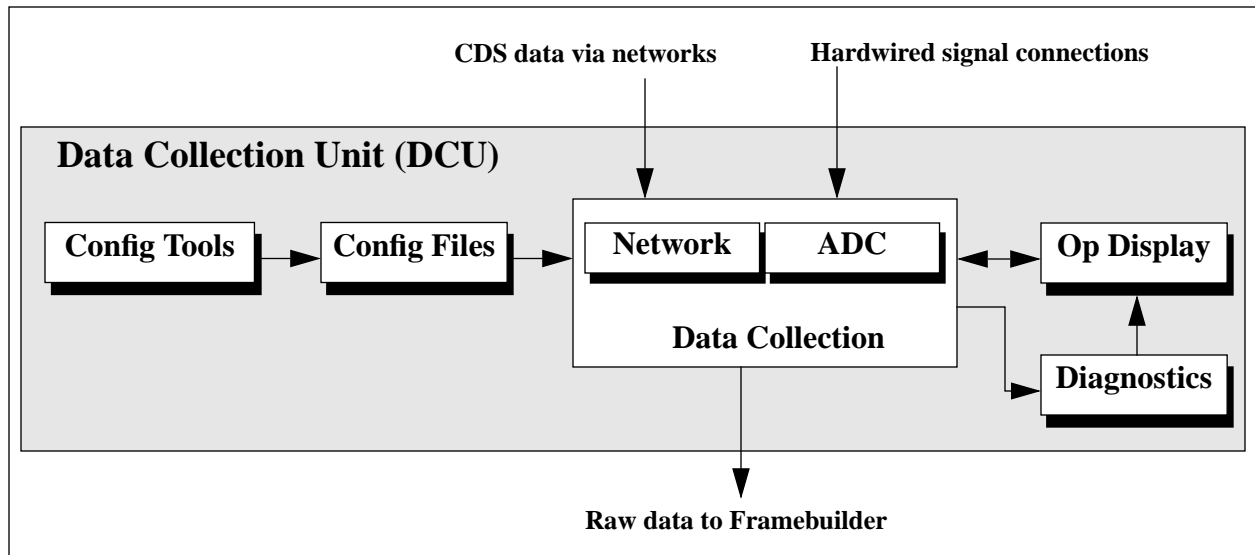

Figure 5: DCU Block Diagram

3.1.1.2.1 Interfaces

DCU shall provide the front end interfaces to other CDS systems for the purposes of collecting data. These interfaces shall be in accordance with specifications in section 3.1.3.1 Interfaces to other LIGO detector subsystems.

3.1.1.2.2 Overall Data Capacity

Sufficient DCU shall be provided by the DAQS to, at minimum, continuously acquire the number of data channels and at the rates described in Table 3: Estimated Site Data Channels and Rates.

3.1.1.2.3 Analog to Digital Conversion

3.1.1.2.3.1 ADC Requirements

The DAQ shall directly accept analog signals in the range of -1VDC to +1VDC.

The DAQ shall provide all necessary signal conditioning and Analog to Digital Convertors (ADC).

All ADC shall meet or exceed the following characteristics:

- 16 bit resolution
- Externally triggerable with sample rates to 32K samples/sec.
- Sample jitter less than 10nsec.
- Sample delay less than 75 nsec; multi-board sample time difference <100 nsec when strobed with the same clock and trigger signals.
- Nonlinearity +/- 0.005 percent
- Gain accuracy +/- 0.005 percent, +/- 5 ppm/C

- Offset voltage and drift +/-200 uV, +/-5 uV/C

3.1.1.2.3.2 *Sampling Rate*

The number of samples per second for analog signal data collection shall be selectable in 2^n steps, where $n \geq 4$ and $n \leq 15$ (16 samples/sec to 32768 samples/sec).

3.1.1.2.3.3 *Timing*

The DAQ shall incorporate the LIGO CDS standard timing modules, based on the Global Positioning System (GPS), for data clocking and triggering. The DAQ shall provide all necessary software to configure and read timing data from these modules. All acquired data shall be time tagged to a resolution of 1usec and accuracy better than 10usec.

3.1.1.2.4 *Network Data*

3.1.1.2.4.1 *Dynamic Control and Monitoring Information*

The DAQ shall be capable of accepting data via standard LIGO CDS networks from the LIGO control and monitoring systems. This function shall be provided by standard EPICS channel access routines and protocols.

3.1.1.2.4.2 *Static/Infrequent Data*

At infrequent and asynchronous time intervals, data will be sent to the DAQS from the control and monitoring systems and IFO diagnostics which needs to be archived along with the continuous data stream of the DAQS. Therefore, the DAQS shall provide network facilities to accept and store this data.

3.1.1.2.5 *Diagnostics*

The DAQS shall provide diagnostics of acquisition front ends, including:

- State information, including:
 - > Fault, including description of fault condition
 - > Configure: DCU is on, but not configured to run
 - > Ready: DCU configured and ready to acquire data
 - > Acquire: DCU is acquiring data normally
- Present Configuration
- CPU Usage
- Data Rates

3.1.1.2.6 *Operation*

3.1.1.2.6.1 *Normal*

In normal operation, each DCU shall acquire data in accordance with its loaded configuration and provide the defined self-diagnostic information and statistics.

3.1.1.2.6.2 Reconfiguration

Whenever a new configuration is loaded to DCU, the DAQS shall place this configuration information in the DAQS on-line database (described later), noting the time that the new configuration was implemented. Since it may be necessary during the data analysis phase to go back and determine channel configurations at any given point in time, this configuration data shall be placed into the database in such a manner as configuration history information is not lost.

When reconfiguration is activated, the DAQS shall coordinate its activities such that the new DCU data acquisition is seamlessly and synchronously incorporated into the total system acquisition i.e. no disruption of data acquisition occurs.

3.1.1.2.6.3 Power Up

On application of power to a DCU, the DAQS shall be designed in such a fashion that the DCU automatically is configured according to the present DAQS configuration and assumes the state of the DAQS. If the present state of the DAQS requires the newly powered up DCU to be on-line and acquiring data, the DAQS shall seamlessly and synchronously reintroduce data acquired from this DCU.

3.1.1.2.6.4 Fault

The DAQS shall be designed in such a fashion as to reduce the amount of data lost on a single DCU or DCU component failure.

3.1.1.2.6.5 Fault Recovery

On repair or recovery from a fault, if the DAQS is in acquisition mode, the DAQS shall seamlessly and synchronously reintroduce the DCU data into the acquisition data stream.

3.1.1.2.7 Runtime User Interface

An X-windows based interface shall be provided which, at minimum:

- Displays the diagnostic information for all DCU
- Allows the operator to place each DCU on-line (operate mode) or off-line (non-operating mode)
- Allows the operator to load a configuration (developed with configuration tools described in the following section) to each/all DCU.

3.1.1.2.8 Configuration

The DAQS shall provide off-line tools for the configuration and assignment of data channels to each DCU. This shall include the following information for each channel:

- Name tag with TBD standard format.
- Channel description text
- System (IFO1, IFO2, Site; the latter pertains to PEM and other data not directly associated with a particular IFO)
- Physical channel assignment (e.g. channel 21 of ADC module 2 in DCU crate 7)
- Default sample rate

- Calibration data
- Pre-ADC whitening information

Utilities shall be included to save and restore configuration files generated with these tools.

3.1.1.3 Framebuilder

The DAQS shall provide a “framebuilder”, which shall perform the functions of:

- Assembling the acquired data into standard data formats
- Providing this assembled data to DAQS storage and distribution units.

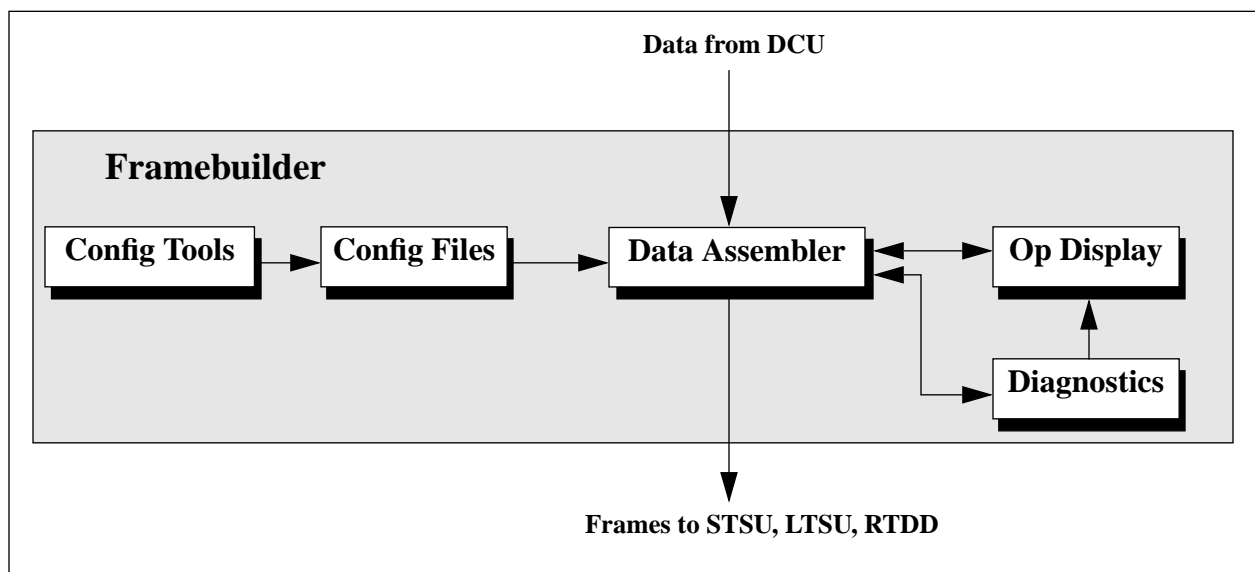

Figure 6: Framebuilder Block Diagram

3.1.1.3.1 Data Assembly

Once data has been collected from the various interfaces located across the LIGO site, the data shall be organized into what has come to be known as data “frames”. These frames are of several types:

- Complete Data Frames (CDF), which encompass the entirety of data being acquired by the DAQS destined for long/short term storage.
- Limited Data Frames (LDF), which contain only a limited number of data channels.
- Special Purpose Frames (SPF), which hold the static/infrequent data, such as calibration information, IFO state vectors, etc.
- Diagnostic Data Frames (DDF), which are intended to be distributed to on-line analysis and diagnostic functions.

3.1.1.3.1.1 *General Frame Characteristics*

3.1.1.3.1.1.1 *Frame Timing*

All frames shall be of fixed time duration. This time interval shall be user selectable to 1, 2, 4 or 8 seconds.

3.1.1.3.1.1.2 *Frame Header*

All frames shall contain a header which includes:

- Time stamp marker corresponding to the start time of the data contained in the frame.
- Frame type identification and information on the overall composition of the frame.
- Sufficient self descriptors to identify the characteristics of the data contained in the frame (either in the frame itself or pointers to information stored elsewhere), including:
 - > Channel Name
 - > Channel Description
 - > Channel Sample Rate
 - > Channel Calibration Information
 - > Channel pre-ADC whitening filter information

3.1.1.3.1.2 *Complete Data Frames (CDF)*

The DAQS is required to store all data channels being acquired as a single frame unit of selectable time duration to long term and short term storage. To support this requirement, the DAQS shall provide CDF which contain:

- Frame header, as described in section 3.1.1.3.1.1.2 Frame Header.
- All raw data acquired by the DAQS from all channels during the time period covered by the frame.

This data shall be assembled within this frame construct in a TBD format.

Initially, the DAQS shall provide standard CDF of the following subtypes:

- CDF1: All data channels from IFO1 and all Site data channels
- CDF2: All data channels from IFO2 and all Site data channels (Hanford only)

3.1.1.3.1.3 *Limited Data Frames (LDF)*

The DAQS shall provide the capability to define and build frames which contain a subset of the CDF. These Limited Data Frames (LDF) shall contain the same header information as the CDF but differ in that they contain only data for user specified channels.

Initially, the DAQS shall provide the following predefined LDF subtypes:

- LDF1: Asymmetric port data from IFO1
- LDF2: Asymmetric port data from IFO2 (Hanford site only)
- LDF3: Asymmetric port data from IFO1 and IFO2 (Hanford site only)
- LDF4: Asymmetric port data from IFO1 and IFO2 at Hanford and IFO1 from Livingston

Note: These predefined frames may be required to contain TBD IFO calibration data and/or data quality information. With these additional items, each LDF would then contain all information necessary to perform on-line analysis.

3.1.1.3.1.4 *Special Purpose Frames (SPF)*

It is expected that various static and infrequent asynchronous data will be also be acquired and archived by the DAQS. Examples of this type of data are:

- Qualified data time span list (e.g. ignore frame 0000x, 00y00,...)
- Measured frequency response transfer functions (e.g. strain calibrations)
- Machine state descriptions
- IFO diagnostic and video snapshots

To support this functionality, the DAQS shall provide TBD SPF with TBD formats.

3.1.1.3.1.5 *Diagnostic Data Frames (DDF)*

For on-line diagnostics or analysis, various systems will require individual or subsets of channels to be provided by the DAQS. Therefore, the DAQS shall provide, on request, frames which contain subsets of channels with a TBD format. (Note: these frames differ from LDF in that they will contain a different, limited TBD header.

3.1.1.3.1.6 *Data Filtering*

The sample rate of channel data to be stored in a frame may differ from the rate at which it is being acquired by the DCU. Therefore, the framebuilder shall provide data filtering in the form of:

- Decimation
- Averaging

Example: DCU is acquiring channel X at 16K samples/sec and user requires data in the frame for channel X at 4K samples/sec. The user can specify decimation, whereby every fourth data sample is stored in the frame, or averaging, whereby groups of four samples from the DCU are averaged and written as a single sample to the frame.

3.1.1.3.2 *Configuration Tools*

The DAQS shall provide initial standard frame formats. In addition, it shall supply methods to develop new frame types/formats.

3.1.1.3.3 *Operation*

3.1.1.3.3.1 *Normal*

In normal operating mode, the Framebuilder shall accept data from DAQS DCU and assemble that data into frames as defined by the loaded configuration. The framebuilder, in turn, shall make this framed data available to the long/short term storage units and RT data distribution units (described in following sections). The framebuilder shall have sufficient performance such that the overall performance specifications of the DAQS and its other functional units are met.

3.1.1.3.3.2 *Reconfiguration*

Whenever DCU are reconfigured, the framebuilder shall automatically reconfigure itself for the new channel selections and rates. Also, the framebuilder shall automatically respond to requests from storage units and the real-time distribution unit for new data and frame types.

3.1.1.3.4 Diagnostics

The framebuilder shall provide self diagnostics, including, at minimum, the same information as described for the DCU in section 3.1.1.2.5 Diagnostics.

3.1.1.4 Long Term Storage Unit (LTSU)

Once data has been assembled into frames, the DAQS shall provide the capability to archive this data for long term storage. At minimum, the DAQS shall provide two LTSU, one capable of continuously storing CDF at the full data rate and one capable of storing LDF (with up to 20 data channels) continuously at the full data rate.

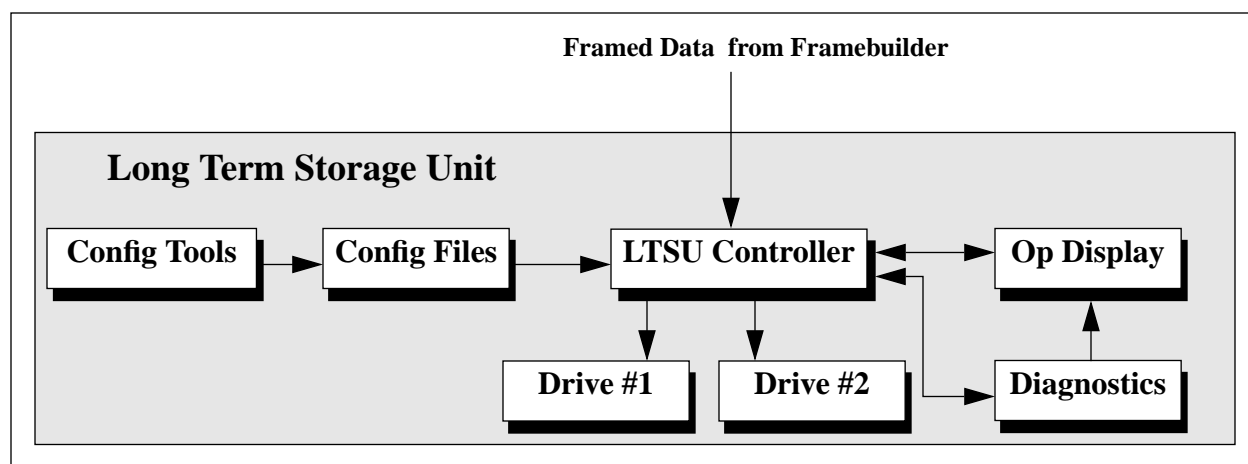

Figure 7: LTSU Block Diagram

3.1.1.4.1 General Requirements

- The long term storage units and media shall be capable of storing continuously at the same or greater rate than the data is being acquired.
- No loss of data shall occur during media change out periods i.e. a minimum of two media drives shall be attached to each LTSU.
- Storage media shall be certified to have a lifetime of greater than 5 years i.e. data on storage media will not be corrupted/lost due to aging effects.
- Storage media shall be such that it is compatible with commercial robotic systems, which may later be employed by other LIGO data analysis and distribution systems.

3.1.1.4.2 Media Header Information

Along with the frames, a media preamble and media summary shall be written to each removable media.

3.1.1.4.2.1 Media Preambles

Each removable long term storage media shall contain a minimum preamble to identify it. The preamble shall contain, at a minimum:

- Media ID
- Site
- IFO number
- Date (local and GMT)
- Time (local and GMT)
- Detector location (latitude and longitude)
- Detector arm orientation
- DAQS software version
- IFO mode (recycled, dual-recycled, etc.)
- Operational Mode (normal observation, research & development, diagnostics, etc.)
- Initial IFO state vectors
- Initial transfer functions
- Pre-ADC whitening filters used to reduce dynamic range
- Flexible format which allows for expansion of this list

3.1.1.4.2.2 Media Summary

Each removeable long term storage media shall contain summary information for the time period covered on that media. This summary information shall include TBD summary and statistical information on the various characteristics of the data and the interferometer that are accumulated during the recording period.

3.1.1.4.3 Operation

3.1.1.4.3.1 Normal

During normal operation, an LTSU shall continuously archive all data frames listed in its configuration. These frames are to be provided by the previously defined framebuilder.

3.1.1.4.3.2 Reconfiguration

An LTSU shall be reconfigured by loading a new configuration file which lists the frame types that are to be archived. The LTSU shall coordinate with the Framebuilder such that the LTSU continues to be provided with and archives the present frames until both units are ready to switch to the new frame definitions. This shall be executed such that there is no time lapse in the archived data.

3.1.1.4.3.3 Power Up

On power up, an LTSU shall perform all necessary self diagnostics and await configuration and start commands.

3.1.1.4.3.4 Fault

On failure of a storage drive unit, the LTSU shall automatically notify operators and attempt to go to any available backup unit.

3.1.1.4.4 Configuration

The DAQS shall provide configuration tools which provide the following functionality, as outlined in Figure 8: LTSU Configuration:

1. Ability to select channels and sample rates for LDF.
2. Save the channel selections and rates to a file as an LDF subtype.
3. Provide a standard library of available CDF and SPF.
4. Browse the LDF files and standard frame file; select/deselect those frame types which are to be written to the storage media.
5. Save the selected set of frames to a composite frame file
6. Either from a composite frame file or directly from (4) above, load the configuration to the storage unit for runtime execution.

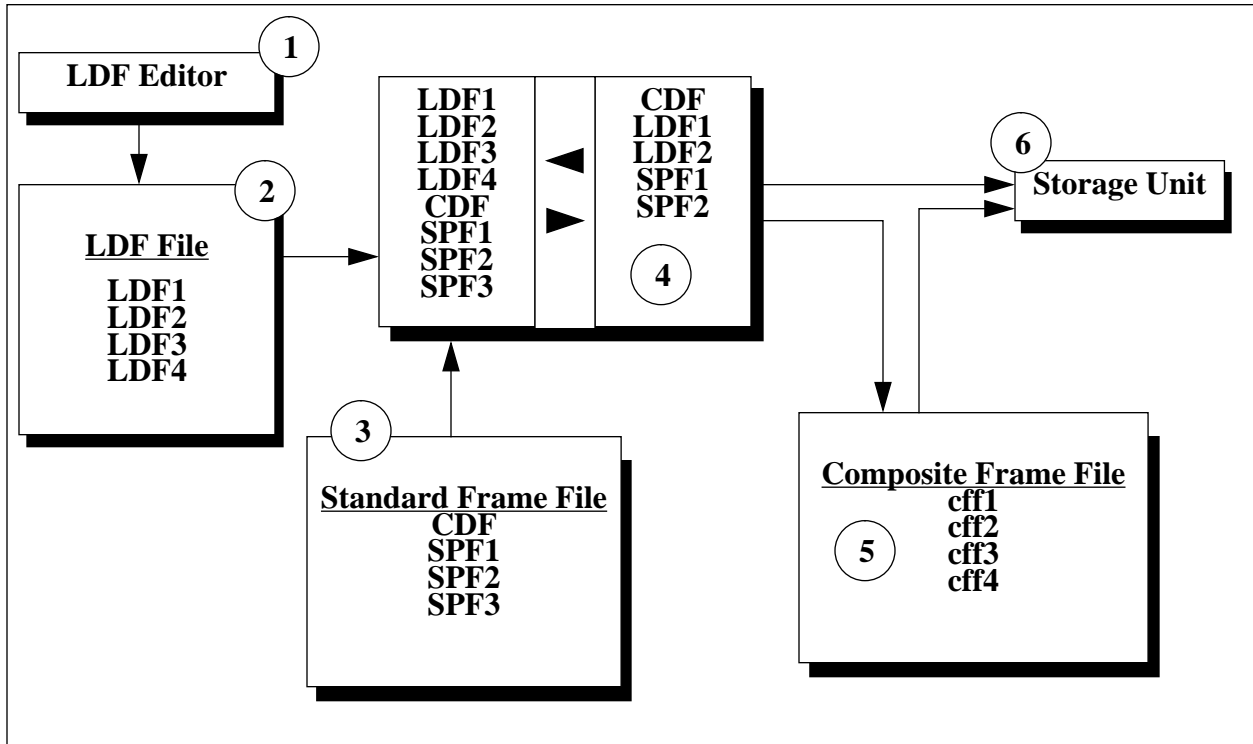

Figure 8: LTSU Configuration

3.1.1.4.5 Diagnostics

LTSU shall be provided with self diagnostics:

- Overall operational Status
 - > Fault, including information on the cause of the fault
 - > Config: LTSU available for operation but has not been configured
 - > Ready: LTSU available and configured for operation
 - > Archive: LTSU is on-line and archiving data
- Drive and media status

3.1.1.4.6 Runtime User Interface

3.1.1.4.6.1 LTSU Control

An X-windows based user interface shall be provided which allows users of the DAQS to control the following LTSU parameters:

- Start/Stop LTSU data archival
- Change LTSU configurations (frame types to be archived)
- Switch drive media (e.g. stop archival of data to present drive and start archival to second drive associated with the LTSU)

3.1.1.4.6.2 LTSU Status Information

An X-windows based user interface shall be provided, which depicts the following minimum information on each LTSU:

- Configuration
- Status
- Run Number/Description
- Start time (time present run started)
- Elapsed time (time since present run was started)
- IFO lock time (the amount of time that the IFO, from which data is being archived, has been in lock since the start of the run)
- IFO “lost lock” count. (Number of times IFO has lost lock since start of data run.)

In addition, for each media drive associated with an LTSU, the following information shall be displayed:

- Status
 - > Fault, along with fault information
 - > Ready: Media is loaded and ready to accept data
 - > Pending: New media has been loaded and is being prepared or housekeeping is being performed on a full media (rewind, tape headers, etc.)
 - > Media Full: Operations staff shall be alerted at least 30 minutes before a new media is required in a drive.
- Capacity
- Start Time (Time when writing started to the present media loaded in the drive)
- Elapsed Time (Since present media on drive was started)
- Data Rate
- Percent Full
- Time to Full

3.1.1.5 Short Term Storage Units

Certain data must be stored to random access disk drives for quicker data access by on-line analysis systems and the IFO diagnostics system. The storage and retrieval of this data is to be done by the STSU as shown in Figure 9: STSU Block Diagram.

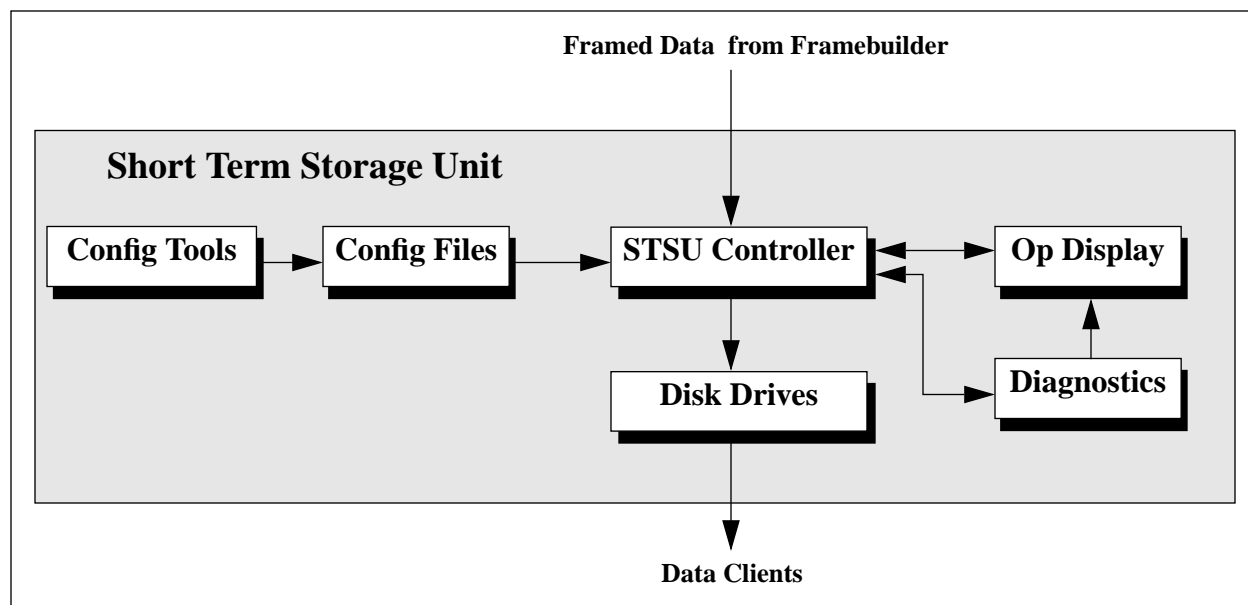

Figure 9: STSU Block Diagram

3.1.1.5.1 General Requirements

3.1.1.5.1.1 Storage Capacity

The DAQS shall provide short term data storage facilities at each LIGO site in the form of randomly accessible disk space, with the capacity and performance to simultaneously store:

- 8 hours of full site CDF (to support binary inspiral searches, which require a minimum of 5 hours of data and as much as 16 hours).
- 10 days of LDF (types 1-3) (to support periodic source searches).

For the Hanford site, this would require ~400GBytes of disk for data plus some overhead for framing information. The Livingston site would require approximately half of this number.

NOTE: Quantity of data being recorded may be greatly reduced if, as has been suggested, gravity wave analysis only requires 4KHz sampling rate for the signals that are listed as being acquired at 16KHz in Table 3: Estimated Site Data Channels and Rates.

3.1.1.5.1.2 Storage Rates

The DAQS STSU(s) shall support data storage rates to 20MBytes/sec.

3.1.1.5.1.3 Data Retrieval

The STSU shall provide access to data via standard NFS mounting of the drives by other LIGO computing systems.

3.1.1.5.2 Configuration

Configuration tools shall be provided to configure and setup STSU in a manner similar to that as described for the LTSU in section 3.1.1.4.4 Configuration, with the following additions at step 6:

- The amount of disk space to be occupied by frames described in the composite frame file is specified by the user in time.
- The disk space allotted can be set up for a single data run (acquisition stops once all allotted disk space is written to) or in a circular buffer mode (acquisition continues back at the beginning of the set disk space once the end of allocated space is reached).

3.1.1.5.3 Diagnostics

STSU shall be provided with self diagnostics, including:

- Overall operational status
 - > Fault, including cause information
 - > Drive and media status
 - > Data rates

3.1.1.5.4 Runtime User Interface

A runtime user interface shall be provided, which includes:

- STSU diagnostic information
- Storage capacities and usage
- Status of data runs in progress
- Ability to configure, start/stop data runs

3.1.1.6 Real-time Data Distribution Unit (RDDU)

3.1.1.6.1 General Requirements

For a TBD limited number of clients, the DAQS shall directly supply data frames via TBD CDS networks. This data shall be delivered directly from the framebuilder (i.e. after data assembly but before data storage). This data shall be delivered at full DAQS rates, with a delay from time of DCU acquisition to network delivery not to exceed TBD seconds.

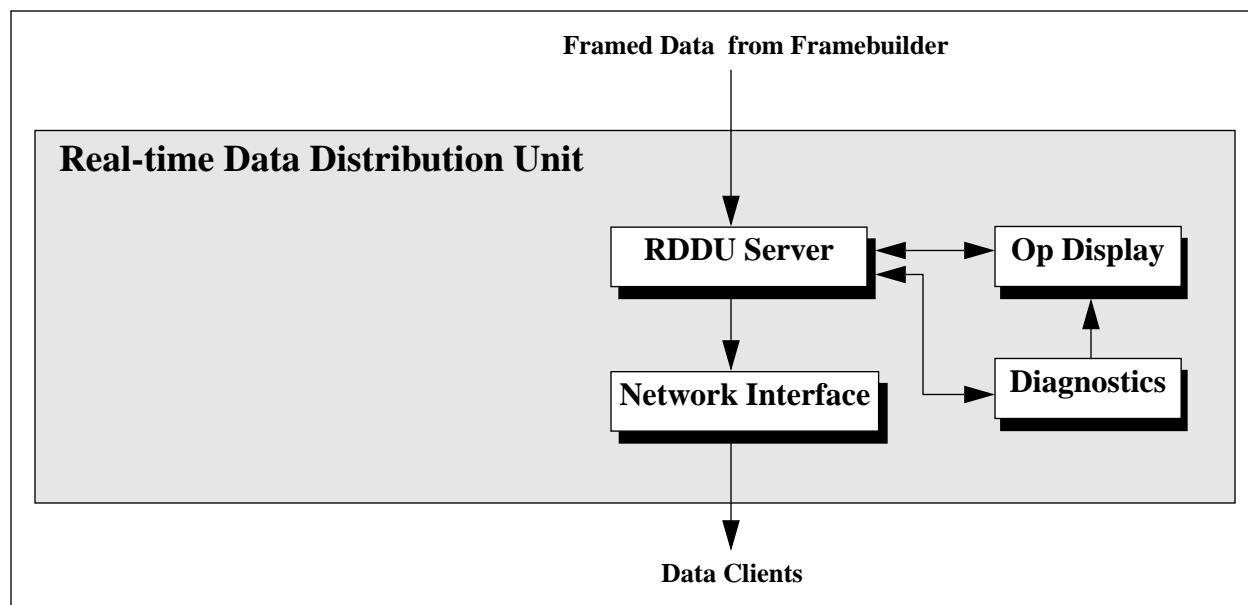

Figure 10: RDDU Block Diagram

3.1.1.6.2 Interface

The RDDU shall provide data in a client/server mode, responding to data requests from various on-line systems. The DAQS shall provide API calls to the RDDU server in the form of ANSI C code functions which are embedded in and compiled with client software.

3.1.1.6.3 Diagnostics

The RDDU shall provide self diagnostics, including:

- Number of client requests
- Statistics on each request (data rates, CPU usage, etc.)
- Overall performance statistics (total requests, data rates, CPU usage, etc.)
- RDDU faults

3.1.1.7 On-Line Database

For the purposes of on-line lookup of certain DAQS information, the DAQS shall provide an on-line database.

3.1.1.7.1 Access

The DAQS database shall be accessible from on and off site via CDS and LIGO general computing networks. It shall be configured as a server with TBD provided client applications.

3.1.1.7.2 Data

Data stored by the database shall include:

- Information on tapes written by the LTSU, including:
 - > Tape serial numbers
 - > Associated tape header information (defined previously)
 - > Tape storage location
- Channel calibration data
- IFO general configuration and performance information
- DAQS configuration information

3.1.1.7.3 Capacity

The database and its associated storage media shall have sufficient capacity to maintain data on line for the previous six months of operation. Long term storage shall be provided to back up data that is older than six months.

3.1.2. Physical Characteristics

3.1.2.1 Electronic equipment housings

To the extent possible and reasonable, all DAQS electronic equipment shall be housed in standard 19" racks.

3.1.2.2 Weight Limits

DAQS equipment to be housed within the OSB shall not exceed weight limits imposed by the building raised floor loading capacities.

3.1.3. Interface Definitions

3.1.3.1 Interfaces to other LIGO detector subsystems

3.1.3.1.1 Mechanical Interfaces

It is intended that, to the extent possible, DAQS use electrical equipment housings provided by CDS control and monitoring systems. As such, the mechanical interfaces to these systems are:

- 19" equipment racks
- VME crates

3.1.3.1.2 Electrical Interfaces

3.1.3.1.2.1 Direct Analog Signal Connection

The interface for direct analog connections shall be at the designated cable patch panels provided by control and monitoring systems of the CDS, located within CDS racks at various locations throughout the LIGO LVEA, and mid and end stations.

3.1.3.1.2.2 Network Connections

Slow (<10Hz) data will be provided by various CDS control and monitoring systems via CDS networks. The CDS control and monitoring infrastructure shall provide a CDS network connection at all points required by the DAQS.

If special networks not generally supported by the control and monitoring systems are required for DAQS data transmissions, those networks shall be provided by the DAQS.

3.1.3.1.2.3 Electrical Power

Electrical power for DAQS equipment co-located in equipment racks with those provided by CDS control and monitoring systems shall be provided at plug strips within the racks. Both surge protected only and UPS supplied power will be available.

3.1.3.1.3 Optical Interfaces

None.

3.1.3.1.4 Stay Clear Zones**3.1.3.2 Interfaces external to LIGO detector subsystems****3.1.3.2.1 Mechanical Interfaces**

TBD.

3.1.3.2.2 Electrical Interfaces

TBD.

3.1.3.2.3 Stay Clear Zones

As per the Detector - Civil Construction and Detector - Vacuum Equipment Interface Control Documents.

3.1.4. Reliability

The Mean Time Before Failure (MTBF) for the DAQS shall be greater than TBD.

3.1.5. Maintainability

The Mean Time To Repair (MTTR) for any DAQS component shall be less than TBD.

3.1.6. Environmental Conditions

The DAQS shall meet all performance requirements when exposed to all specified natural and induced environments.

3.1.6.1 Natural Environment**3.1.6.1.1 Temperature and Humidity**

All DAQS equipment shall meet the following temperature and humidity requirements.

Table 4: Environmental Performance Characteristics

<i>Operating</i>	<i>Non-operating (storage)</i>	<i>Transport</i>
+0 C to +50 C, 0-90%RH	-40 C to +70 C, 0-90% RH	-40 C to +70 C, 0-90% RH

3.1.6.1.2 Atmospheric Pressure

The DAQS equipment design must accommodate atmospheric pressure change from a maximum of 15.2 psia to a minimum of 14.2 psia.

3.1.6.2 Induced Environment**3.1.6.2.1 Vibrations**

DAQS equipment shall not produce mechanical vibrations greater than those specified in TBD.

3.1.6.2.2 Acoustic Noise

DAQS equipment shall be designed to produce the lowest levels of acoustic noise as possible and practical. In any event, DAQS equipment shall not produce acoustic noise levels greater than that defined in LIGO T960083-A, Derivation of CDS Rack Acoustic Noise Specifications.

3.1.6.2.3 Electromagnetic Radiation

The DAQS shall not degrade due to electromagnetic emissions as specified by IEEE C95.1-1991.

The DAQS shall not produce electromagnetic emissions beyond those specified in TBD and shall comply with the LIGO EMC Plan.

3.1.7. Transportability

All items shall be transportable by commercial carrier without degradation in performance. As necessary, provisions shall be made for measuring and controlling environmental conditions (temperature and accelerations) during transport and handling. Special shipping containers, shipping and handling mechanical restraints, and shock isolation shall be utilized to prevent damage. All containers shall be movable for forklift. All items over 100 lbs. which must be moved into place within LIGO buildings shall have appropriate lifting eyes and mechanical strength to be lifted by cranes.

3.2. Design and Construction

3.2.1. Materials and Processes

3.2.1.1 Finishes

- Ambient Environment: Surface-to-surface contact between dissimilar metals shall be controlled in accordance with the best available practices for corrosion prevention and control.
- External surfaces: External surfaces requiring protection shall be painted or otherwise protected in a manner to be approved.

3.2.2. Component Naming

All tagging and naming of DAQS equipment shall be in accordance with LIGO naming standards as described in T950111 LIGO Naming Conventions

3.2.3. Workmanship

All details of workmanship shall be of the highest grade appropriate to the methods and level of fabrication and consistent with the requirements specified herein. There shall be no evidence of poor workmanship that would make the components unsuitable for the purpose intended. All electronic circuits, modules and wiring shall be consistent with good engineering practice and fabricated to best commercial standards.

3.2.4. Interchangeability

The DAQS shall be designed to maximize interchangeability and replaceability of mating components. Using the Line Replaceable Unit (LRU) concept, the designs shall be such that mating assemblies may be exchanged without selection for fit or performance and without modification to the section, the unit being replaced or adjacent equipment. Mature, performance proven, standard, commercially available equipment shall not be modified unless it impacts safety.

3.2.5. Safety

This item shall meet all applicable NSF and other Federal safety regulations, plus those applicable State, Local and LIGO safety requirements. A hazard/risk analysis shall be conducted in accordance with guidelines set forth in the LIGO Project System Safety Management Plan LIGO-M950046-F, section 3.3.2.

3.2.6. Human Engineering

The DAQS shall be designed and laid out in a manner consistent with applicable standard human engineering practices. Particular attention shall be paid to layouts of operator consoles/stations, work space and environmental conditions.

3.3. Documentation

3.3.1. Specifications

The following specifications shall be provided as part of the design process:

- Software Requirements Specification (SRS) for all software to be developed as part of the system.
- Interface Control Document (ICD)

3.3.2. Design Documents

The following design documents shall be provided:

- System overall design.
- System software design.

3.3.3. Engineering Drawings and Associated Lists

Engineering drawings, schematics, wire lists and cable routing lists shall be produced for the DAQS. To the greatest extent possible and practical, electronic copies shall be maintained and available on-line. All drawings shall be formatted according to LIGO standards.

3.3.4. Technical Manuals and Procedures

3.3.4.1 Procedures

Procedures shall be provided for, at minimum,

- Initial installation and setup of equipment
- Normal operation of equipment
- Normal and/or preventative maintenance
- Troubleshooting guide for any anticipated potential malfunctions DAQS

3.3.4.2 Manuals

The following manuals shall be provided:

- All manuals provided by commercial vendors for DAQS components.
- Manuals for all DAQS custom designed electronics and software.
- DAQS User's Manual

3.3.5. Documentation Numbering

All documents shall be numbered and identified in accordance with L950003 LIGO Document Numbering System.

3.3.6. Test Plans and Procedures

All test plans and procedures shall be developed in accordance with the LIGO Test Plan Guidelines, LIGO document TBD.

3.4. Logistics

The design shall include a list of all recommended spare parts and special test equipment required.

3.5. Precedence

In the event of conflicts between this requirement document and other LIGO documents, the order of precedence shall be in accordance with the LIGO Requirement Specification Tree.

3.6. Qualification

The DAQS design shall be qualified through a series of reviews as prescribed in the LIGO Detector Implementation Plan.

Qualification of various DAQS components and subsystems shall be in accordance with Section 4 of this document.

4 QUALITY ASSURANCE (QA) PROVISIONS

4.1. General

This system shall be tested in accordance with applicable LIGO QA standards.

4.1.1. Responsibility for Tests

The LIGO CDS group shall be responsible for performing and documenting all tests associated with the DAQS.

4.1.2. Special Tests

Due to their critical nature, the isolation valve interlocks shall undergo extensive testing to ensure proper operation.

4.1.3. Configuration Management

Configuration control of specifications and designs shall be in accordance with the LIGO Detector Implementation Plan.

4.2. Quality Conformance Inspections

Design and performance requirements identified in this specification and referenced specifications shall be verified by inspection, analysis, demonstration, similarity, test or a combination thereof per the Verification Matrix, Appendix 1. Verification method selection shall be specified by individual specifications, and documented by appropriate test and evaluation plans and procedures. Verification of compliance to the requirements of this and subsequent specifications may be accomplished by the following methods or combination of methods:

4.2.1. Inspections

Inspection shall be used to determine conformity with requirements that are neither functional nor qualitative; for example, identification marks.

4.2.2. Analysis

Analysis may be used for determination of qualitative and quantitative properties and performance of an item by study, calculation and modeling.

4.2.3. Demonstration

Demonstration may be used for determination of qualitative properties and performance of an item and is accomplished by observation. Verification of an item by this method would be accomplished by using the item for the designated design purpose and would require no special test for final proof of performance.

4.2.4. Similarity

Similarity analysis may be used in lieu of tests when a determination can be made that an item is similar or identical in design to another item that has been previously certified to equivalent or more stringent criteria. Qualification by similarity is subject to Detector management approval.

4.2.5. Test

Test may be used for the determination of quantitative properties and performance of an item by technical means, such as, the use of external resources, such as voltmeters, recorders, and any test equipment necessary for measuring performance. Test equipment used shall be calibrated to the manufacture's specifications and shall have a calibration sticker showing the current calibration status.

5 PREPARATION FOR DELIVERY

Packaging and marking of equipment for delivery shall be in accordance with the Packaging and Marking procedures specified herein.

5.1. Preparation

Equipment shall be appropriately prepared. For example, vacuum components shall be prepared to prevent contamination.

5.2. Packaging

Procedures for packaging shall ensure cleaning, drying, and preservation methods adequate to prevent deterioration, appropriate protective wrapping, adequate package cushioning, and proper containers. Proper protection shall be provided for shipping loads and environmental stress during transportation, hauling and storage.

5.3. Marking

Appropriate identification of the product, both on packages and shipping containers; all markings necessary for delivery and for storage, if applicable; all markings required by regulations, statutes, and common carriers; and all markings necessary for safety and safe delivery shall be provided.

6 NOTES