

LASER INTERFEROMETER GRAVITATIONAL WAVE OBSERVATORY  
- LIGO -

CALIFORNIA INSTITUTE OF TECHNOLOGY  
MASSACHUSETTS INSTITUTE OF TECHNOLOGY

<b>Document Type</b> LIGO-T950106-01 - D 6 Nov 95
<b>ASC Optical Lever Design Requirement Document</b>
David H. Shoemaker, John H. Tappan

*Distribution of this draft:*

Detector Group

This is an internal working note  
of the LIGO Project.

**California Institute of Technology**  
**LIGO Project - MS 51-33**  
**Pasadena CA 91125**  
Phone (818) 395-2129  
Fax (818) 304-9834  
E-mail: info@ligo.caltech.edu

**Massachusetts Institute of Technology**  
**LIGO Project - MS 20B-145**  
**Cambridge, MA 01239**  
Phone (617) 253-4824  
Fax (617) 253-7014  
E-mail: info@ligo.mit.edu

WWW: <http://www.ligo.caltech.edu/>

## Abstract

This is the Design Requirements Document (DRD) for the ASC (Alignment Sensing and Control) Optical Lever. The overall ASC DRD describes the requirements for the system which the Optlev serves. This document may be considered as a part of the Overall ASC DRD.

# 1 INTRODUCTION

## 1.1. Purpose

The purpose of this document is to communicate the requirements for the Optical Lever to the System Engineer and Systems Integration (for a check of flowdown), to other Detector and Facilities tasks the nature of the requirements, and to those who must make a design which fills the requirements.

## 1.2. Scope

- These requirements are for the Optical Lever (or Optlev), a subsystem of the Alignment Sensing and Control.
- The Requirements are for all applications of the Optical lever: both for operational use (where the Optlev is required to maintain operational alignment for short periods of time) and in any role in the Initial Alignment (where it may be part of a search for the beam tube aperture etc.).
- It does not describe the other subsystems of the ASC with which the Optlev may have a complicated and deep interface.

## 1.3. Definitions

The basic naming convention for the Optlev is given in LIGO document T950070-00-D; those components which might lead to confusion, or elements not named therein, are called out here.

**Sensed Optic** The optic, of which the angle is sensed by the optical lever. In general, the optics are suspended; and some of the objects whose angle is stabilized may not be simple mirrors but instead Faraday isolators, lenses, etc.

**Optlev Baseline** The distance from the measurement position detector to the sensed optic. This distance sets the scale for the optical lever.

**Reference Baseline** The distance from the light source second collimator output to the Reference Position Detector

**Injection Baseline** The distance from the light source second collimator output to the Sensed Optic

**Pitch** Angle of motion around a horizontal axis; also called ' $\theta$ '

**Yaw** Angle of motion around the vertical axis; also called ' $\phi$ '

**Measurement Position Detector** The position-sensitive detector which registers changes in the angle of the Sensed Optic

**Reference Position Detector** The position-sensitive detector which registers changes in the angle of the light beam directed towards the Sensed Optic

## 1.4. Acronyms and Abbreviations

**ASC** Alignment Sensing and Control

**CDS** Control and Data System

**OptLev** Optical Lever Alignment System

**SUS** Suspension System, here used to refer to both the Suspension itself and the control systems which make angular motions in response to input control signals.

**Ref Pos Det** The Reference Position Detector

**Meas Pos Det** The Measurement Position Detector

## 1.5. Applicable Documents

### 1.5.1. LIGO Documents

**LIGO-T952007-00-D** ASC DRD, or Alignment Sensing and Control Overall Design Requirements Document

**LIGO-T950070-00-D** Naming Convention and Interface Definition for Optical Lever

**LIGO-T950112-00-D** ASC Optical Lever Specifications and Conceptual Design (rough draft)

### 1.5.2. Non-LIGO Documents

None.

## 2 GENERAL DESCRIPTION

### 2.1. Specification Tree

This document is part of an overall LIGO detector requirement specification tree. The ASC DRD is highlighted in the following figure. This document is part of the ASC DRD.



other parts of the ASC (both proportional and state signals), and provides closed-loop control information to the SUS via the CDS to maintain a predetermined angle of the sensed optic with respect to the Optlev source and sensor positions. While in operation, the ASC Wavefront sensor continually updates the null point of the Optlev system such that if the Wavefront system ceases to operate (e.g., loss of longitudinal lock), the Optlev will maintain the correct operating angle of the sensed optic to bridge the time until lock is re-acquired. Similarly, if a failure of an Optlev unit takes place (e.g., failure of a Optlev laser), the output control signals will be held at their last good value to maintain a nominally correct alignment for a short interim period.

There is nominally one complete Optlev per sensed optic. The principal interface with other Detector subsystems is with the SUS Suspension system via the angular control inputs on the SUS and the ASC Wavefront/Centering system which supplies offsets. Figure 1 shows the elements of one conceptual design which can fill the requirements; the requirements which must make reference to aspects of a specific design use the naming conventions in the figure.

### **2.3. Product Functions**

The Optical Lever system will maintain the externally determined angle of a sensed optic (normally, a suspended optic) for an intermediate duration. It will be the primary control system once the Initial Alignment has brought the optics to within range of the Optical Lever, and until the Wavefront Sensing system starts to function. It has a stability and a noise performance which allows operation of the interferometers at their design sensitivity for short times (order of 1-10 minutes) to allow diagnostic tests. The relationship with the other aspects of the Overall ASC is shown in the ASC DRD, or Alignment Sensing and Control Overall Design Requirements Document (LIGO-T952007-00-D); the principal signal flow is shown in Figure 2.

### **2.4. General Constraints**

Failure of a single OptLev would, in general, make the interferometer not available. LIGO must operate with a high availability; therefore, this subsystem must be designed with high reliability and low mean time to repair.

The OptLev beam will be visible for ease of initial alignment and troubleshooting.

### **2.5. Assumptions and Dependencies**

It is assumed that the Sensed Optics will have a transparency and a reflectivity that are both greater than 1% at the OptLev beam wavelength.

The performance of the Optlev is to some extent dependent on the stability of the Facility foundation slab, and also on the ground noise (ambient and Facility-dependent). We assume (hard data

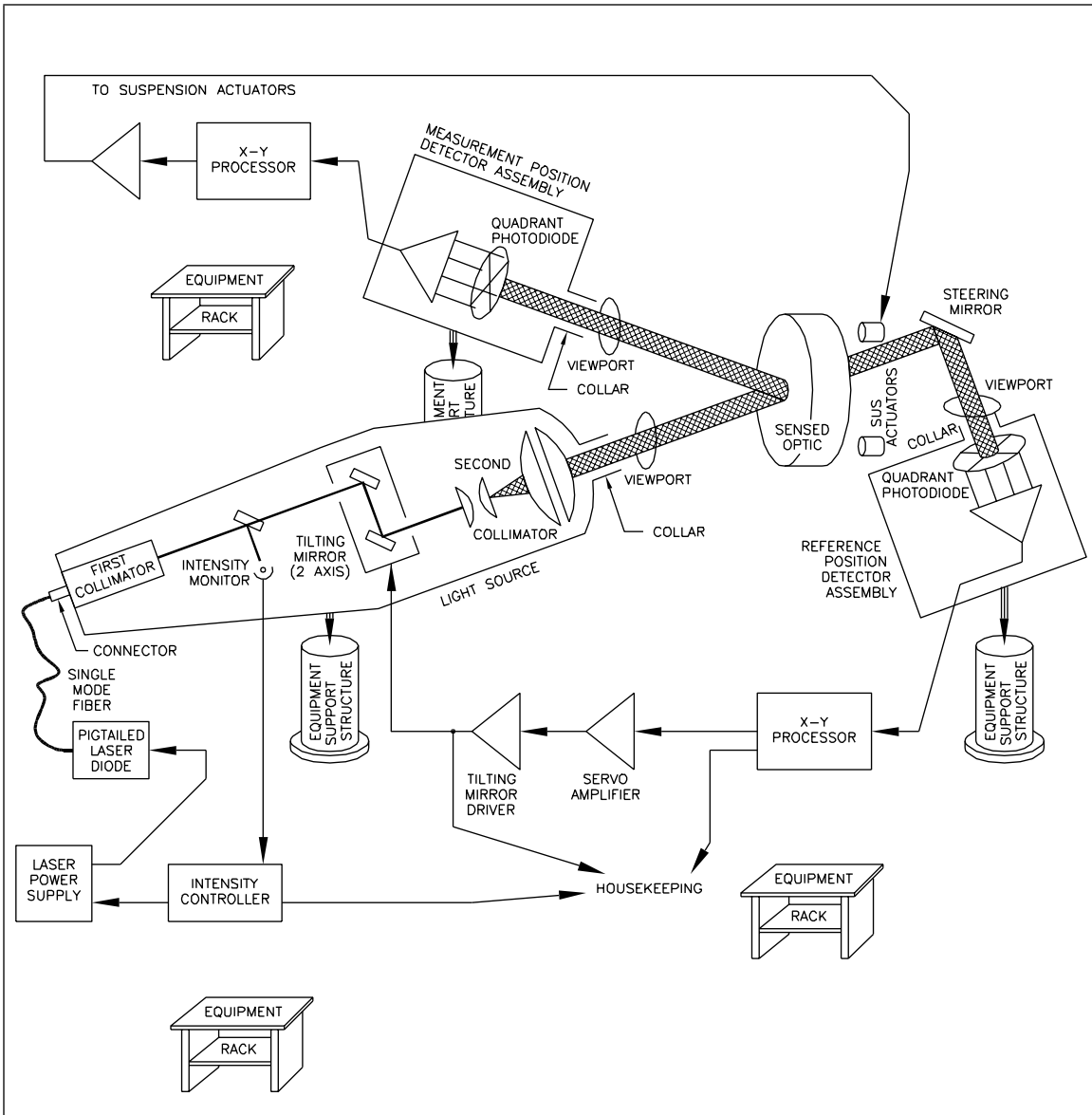

Figure 1: Simplified schematic of an optical lever

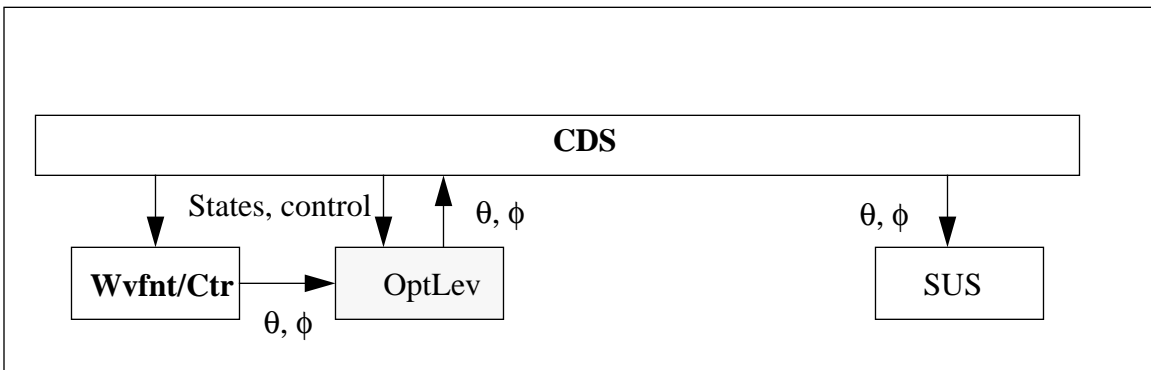

Figure 2: Principal relationships to other subsystems

are not presently available) that these external environmental conditions limit the useful duration of Optlev operational performance to 500 seconds or less.

## 3 REQUIREMENTS

### 3.1. Introduction

The Requirements are summarized in Table 1. The Requirements flow down tree from the Detec-

<i>Paragraph</i>	<i>Requirement</i>	<i>Value</i>
3.2.1.1	System Noise, 10Hz-10 kHz	<1/10 the greater of seismic noise and suspension controller noise
3.2.1.2	System Noise, 0.002-10 Hz	<10 <sup>-8</sup> rad RMS angular motion over this bandwidth in each of $\theta$ and $\phi$
3.2.1.3	Baseline	5m to 50m
3.2.1.4	Dynamic range	> $\pm 10^{-4}$ rad
3.2.1.5	Beam size	<1 cm $1/e^2$ diameter
<b>Table 1: Requirements for the Optlev</b>		

tor DRD to the Overall ASC is shown in Figure 3.

### 3.2. Characteristics

#### 3.2.1. Performance Characteristics

The Optlev shall meet the following performance characteristics after a fully powered warm-up period of 15 minutes.

##### 3.2.1.1 System Noise, 10Hz-10 kHz

The Optlev shall not add rotational noise to the test mass at a level higher than 1/10 the greater of seismic noise and suspension controller noise (in  $m/\sqrt{\text{Hz}}$ ) in this frequency range.

##### 3.2.1.2 System Noise, 0.002-10 Hz

The Optlev shall control the sensed optic to maintain less than 10<sup>-8</sup> rad RMS angular motion over this bandwidth in each of  $\theta$  and  $\phi$ , with respect to the interferometer reference coordinate system. This means that the performance of the interferometer, for optics under Optlev control, will meet our overall interferometer performance requirements for periods of up to 500 sec. (This is written to show independence from the facility foundation stability; if our facility design prevents us from meeting this requirement, a re-configuration of the ASC system will be needed.

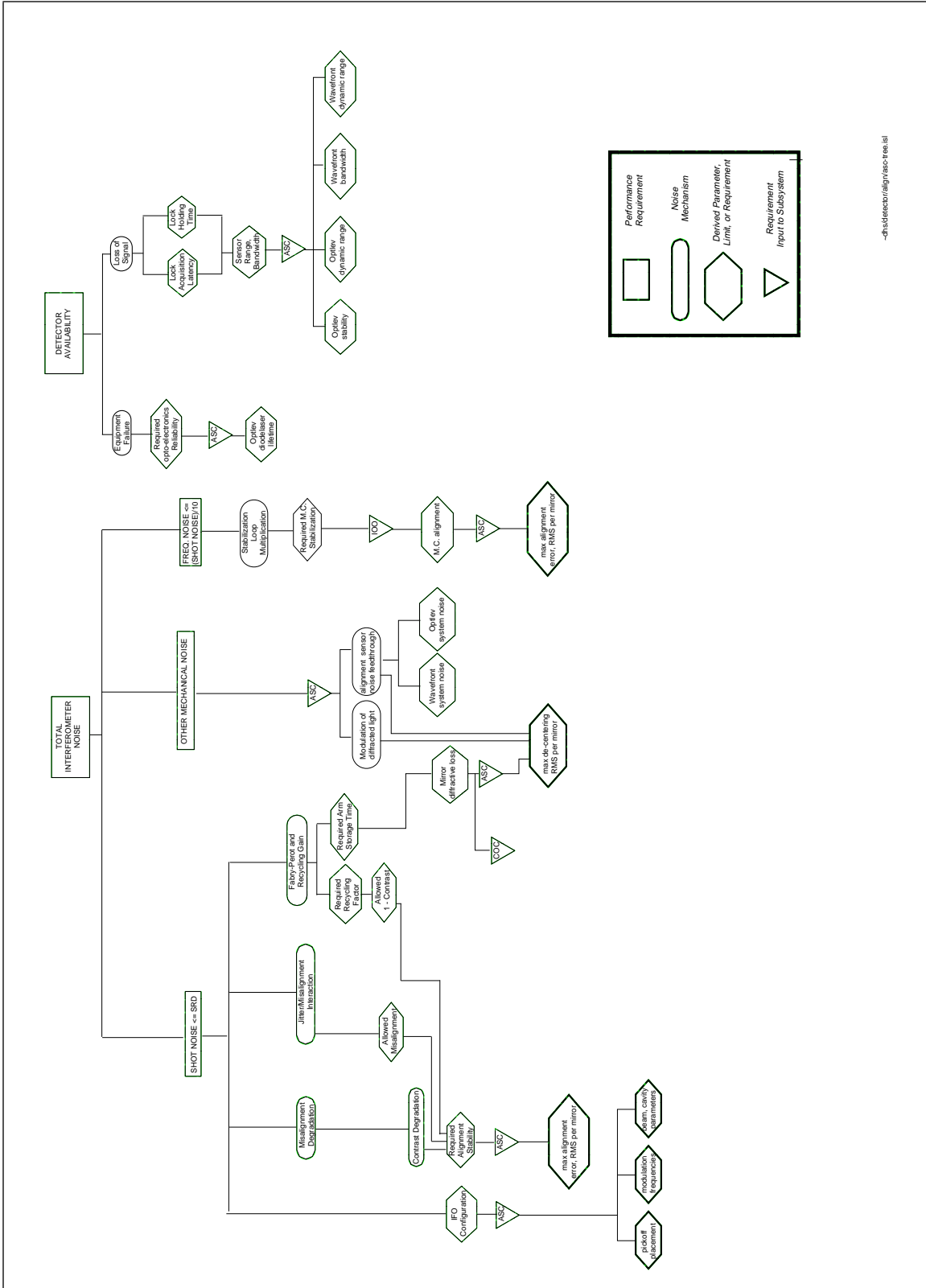

Figure 3: Requirements tree for Overall ASC

This may be quantitative (changes in crossover frequencies) or qualitative (different sensing sys-

tems) depending upon the degree of the problem.)

### 3.2.1.3 Baseline

The Optlev shall deliver the required performance over baselines from 5m to 50m (with possible adjustment of beam sizes (telescope adjustments) and electrical gain changes).

### 3.2.1.4 Dynamic range

The minimum dynamic range shall be  $\pm 10^{-4}$  rad. This ensures that the far end of the 4 km tube is within the dynamic range as first installed, given the requirement for the precision of placement of monuments in the facility and the baselines.

### 3.2.1.5 Beam size

In order to maintain a reasonable freedom of layout for the GW-sensing components of the interferometer, we require that the Optlev beam be a minimum size. This is a layout, not an operational, requirement. The Optlev sensing laser beam size shall not exceed 1 cm  $1/e^2$  diameter anywhere in its trajectory.

The smallest beam size we can use is constrained by several factors, listed below for reference:

- viewport diameter (15 cm free aperture)
- stay-free zones (desire to minimize beam diameter, with roughly 10 mm the point of diminishing returns)
- collimator design (smaller optics lead to less expense, more stable construction)
- quaddiode sizes (integrated quadrant photodiodes are available up to 1.5 cm diameter)
- sensing sensitivity (smaller spots make larger  $dI/d\theta$ )
- diffraction limit for the length and distance traveled. For a beam which grows by  $\sqrt{2}$  from waist to maximum over the nominal distance and with a nominal wavelength, this leads to  $w_0 \approx 3$  mm, or a maximum  $1/e^2$  diameter of 9.3 mm.

## 3.2.2. Physical Characteristics

### 3.2.2.1 Light source

The light source shall be constructed such that thermal gradients from within or external to the system do not induce output beam angle or translations which would limit the dynamic range or noise performance. The light path shall be shielded from air currents such that the noise performance in the 10 Hz-10 kHz domain can be met. The light source shall have mounting surfaces to allow a solid connection to the Equipment Support Structures.

### **3.2.2.2 Reference position detector**

The Ref Pos Det shall have a physical aspect (or sensor head) which minimizes the size viewed head-on to allow several photodetectors to be used at the same output port.

### **3.2.2.3 Measurement position detector assembly**

The Meas Pos Det shall have a physical aspect (or sensor head) which minimizes the size viewed head-on to allow several photodetectors to be used at the same output port. It is to be mounted on an X-Y translator to allow remote positioning; the mounting system shall allow mounting several detectors in close juxtaposition.

### **3.2.2.4 Equipment support structures**

The Light Source, Ref Pos Det, and Meas Pos Det will be mounted on Equipment Support Structures that shall accommodate several sources or detectors at the same time. The Equipment Support Structure shall incorporate a kinematic mount in its base so that, once assembled and aligned for a given position, it can be removed and replaced without needing realignment. That part of the kinematic base that remains fixed to the floor shall not project above the surface of the floor by more than 6cm. The Equipment Support Structure must provide the mechanical stability needed for the function of the OptLev. It is not expected to have any active stabilizing mechanism and so it is not expected to provide any improvement in the stability available from the Facility. It is desired that the Equipment Support Structure have an adjustable or modular design that would accommodate use in various locations.

### **3.2.2.5 Laser Diode and power supply**

The Laser Diode and power supply shall be mounted away from the Light Source to allow changeout (via connectorized demountable optical fibers) without disturbing the optical alignment. This stabilizes the light beam geometry, minimizes the down-time for repairs, and keeps heat sources away from the optical system (to reduce thermal gradients).

### **3.2.2.6 Control electronics**

The control electronics shall be designed and partitioned to keep the power dissipation near the optics to a minimum (to reduce thermal gradients).

### 3.2.3. Interface Definitions

#### 3.2.3.1 Interfaces to other LIGO detector subsystems

##### 3.2.3.1.1 Mechanical Interfaces

**Table 2: Mechanical Interfaces**

<i>OPTLEV Mounting Surface</i>	<i>Other Subsys Mounting Surface</i>	<i>Interface and its Characteristics</i>
Shelves on or slots in Equipment Rack	CDS components <ul style="list-style-type: none"> <li>• Intensity Control</li> <li>• Tilt Mirror Drive</li> <li>• Servo Amp (2)</li> <li>• X-Y Proc. (2)</li> </ul>	TBD
Steering Mirror Support	SEI or SUS depending on Sensed Optic location	TBD
Cables (CDS)	On Floor, or in cable trays	TBD

##### 3.2.3.1.2 Electrical Interfaces

The electrical interfaces are described by the nature of the signal, the source of the signal, and its destination. Interfaces within the Optical Lever are not called out (e.g., between the light source and the power supply or servo amplifier); these will be described in the Conceptual Design for the Optical Lever. Interfaces to CDS indicate housekeeping and operator instructions.

**Table 3: Electrical Interfaces**

<i>Nature of signal</i>	<i>source</i>	<i>destination</i>
angular control signals ( $\theta$ , $\phi$ )	Optlev	Each suspended optic, in IOO, COC
offsets to summing junctions	ASC Wavefront	Optlev
all sensor and actuator signals: <ul style="list-style-type: none"> <li>• quad diode photocurrents</li> <li>• laser intensity monitor</li> <li>• tilting mirror driver outputs</li> <li>• intensity controller output</li> </ul>	Optlev	CDS
gain and offset adjusts for servoloops: <ul style="list-style-type: none"> <li>• laser diode intensity</li> <li>• Optlev beam pointing loops, in <math>\theta</math>, <math>\phi</math></li> <li>• Sensed optic pointing loops, in <math>\theta</math>, <math>\phi</math></li> </ul>	CDS	Optlev

### 3.2.3.1.3 *Optical Interfaces*

The OptLev beams contact the COC and IOO components, but there is no direct optical interface with the GW-sensing beam. Optlev provides the viewports for the input/output Optlev beams.

### 3.2.3.1.4 *Physical Stay Clear Zones*

All stay-clear zones which interact with the detector subsystems are in the vacuum. Clear paths for the OptLev measurement and reference beams are required. In addition, space on the SEI stack tables must be available for steering mirrors and associated hardware.

## 3.2.3.2 **Interfaces external to LIGO detector subsystems**

### 3.2.3.2.1 *External Mechanical Interfaces*

**Table 4: Mechanical Interfaces External to Detector**

<i>OPTLEV Mounting Surface</i>	<i>Other Subsys Mounting Surface</i>	<i>Interface and its Characteristics</i>
Base of Equipment Rack	Floor (FAC)	Table legs that are not bolted to the floor
Base of Equipment Support Structures	Floor (FAC)	Kinematic Base w/ clamp
Viewports	VacEq surface to depend on Sensed Optic location	High Vacuum Flange, Style, Bolt Circle or Clamps, and Seal TBD

Equipment support structures: The support structures are small optical tables on rigid supports. It shall be possible to locate any of them with GPS accuracy using a limited number of precision monuments (not in Optlev) and surveying techniques.

Each Equipment Support Structure will include a kinematic mount in its base, one half of which will be mounted somewhat permanently to the Facility floor. The mounting of this fixed half shall not require special pre-existing features of the floor. It may require holes to be drilled into the floor to accommodate mechanical fasteners.

### 3.2.3.2.2 *External Electrical Interfaces*

None.

### 3.2.3.2.3 *External Stay Clear Zones*

3.2.3.2.3.1 *Civil construction interfaces:* Space for the Mechanical Interfaces described above. All space between the LN2 traps and the beam manifold reducers and the facility floor underneath; 1 m<sup>2</sup> spaces at the Test Mass BSCs at beam height, and 1 m<sup>2</sup> spaces on one side of

each HAM.

**3.2.3.2.3.2 Vacuum Equipment interfaces:** The light paths for the Optlev will require that the viewports not be blocked by internal mechanical features, or that the necking on the viewports limit too severely the free aperture of the viewport.

### **3.2.4. Reliability**

#### **3.2.4.1 MTBF**

The MTBF shall be such that the Optical Lever systems on the interferometer do not exceed their budget for the compromise of the availability of the interferometer. Note that there is one OptLev per suspended optic.

### **3.2.5. Maintainability**

Mean Time To Repair (MTTR); TBD. The goal will be for 15 minutes to replace the faulty part once the person and material are at the place of the fault IF the repair does not require an optical realignment. The equipment shall be designed to make repairs of the equipment most likely to fail such that no realignment is needed.

#### **3.2.5.1 Laser Diode and power supply**

The Laser Diode and power supply shall be mounted via connectorized demountable optical fibers. All equipment shall be connected with cables with connectors at both ends.

### **3.2.6. Environmental Conditions**

#### **3.2.6.1 Natural Environment**

##### **3.2.6.1.1 Temperature and Humidity**

**Table 5: Environmental Performance Characteristics**

<i>Operating</i>	<i>Non-operating (storage)</i>	<i>Transport</i>
+20 C to +25 C, 20-70% RH noncondensing	0 C to +60 C, 10-90% RH noncondensing	0 C to +60 C, 10-90% RH noncondensing

##### **3.2.6.1.2 Atmospheric Pressure**

The Optlev components shall function under normal Atmospheric pressure conditions (0.7-1.1 ATM).

### **3.2.6.1.3 *Seismic Disturbance***

The Seismic background and Facility Drift are primary sources against which this system operates. No special requirements are put on these disturbances, however, due to cost realities.

### **3.2.6.2 *Induced Environment***

#### **3.2.6.2.1 *Electromagnetic Radiation***

The Optical Lever system produces laser light at the long-wavelength end of the optical spectrum (around 630-670 nm) at a power level of <10 mW. The GW-sensing system (operating at around 1064 nm) should carry dichroic filters to eliminate light from all other wavelengths including the Optlev wavelength.

#### **3.2.6.2.2 *Acoustic***

The Optlev components shall function as required under normal acoustic conditions found in the LVEA.

#### **3.2.6.2.3 *Mechanical Vibration***

The Optlev components shall function as required under normal mechanical/seismic conditions found in the LVEA.

### **3.2.7. *Transportability***

All items shall be transportable by commercial carrier without degradation in performance. As necessary, provisions shall be made for measuring and controlling environmental conditions (temperature and accelerations) during transport and handling. Special shipping containers, shipping and handling mechanical restraints, and shock isolation shall be utilized to prevent damage. All containers shall be movable for forklift. All items over 100 lbs. which must be moved into place within LIGO buildings shall have appropriate lifting eyes and mechanical strength to be lifted by cranes.

It is anticipated that the final alignment of the output collimators will be performed on-site.

## **3.3. *Design and Construction***

### **3.3.1. *Materials and Processes***

#### **3.3.1.1 *Finishes***

Mounting surfaces will be designed to make a well-defined plane of contact. Kinematic mounts will be used where possible.

### **3.3.1.2 Materials**

The relay mirrors in the vacuum must be prepared with only approved vacuum-compatible materials and manufactured, cleaned, and handled according to procedures approved for in-vacuum equipment.

All of the remaining parts of the Optlev are in the LVEA, and have minimal additional special material requirements.

### **3.3.1.3 Processes**

TBD.

### **3.3.2. Component Naming**

All components shall be identified using the LIGO Detector Naming Convention (document TBD). This shall include identification physically on components, in all drawings and in all related documentation.

### **3.3.3. Workmanship**

No special considerations have been identified.

### **3.3.4. Interchangeability**

All components will be fully interchangeable, with the following restrictions (refer to Figure 1 for nomenclature):

- The second collimators may be different in lens curvatures and lens placement, but will all fit into a standard mounting system in the standard light source.
- The Collars which adapt from the second collimator to the viewport may differ in length, but will interface in a standard way with the light source
- The gains in the Photodetectors may differ from Optlev to Optlev to account for different light levels, but the circuit boards will be standard so that retrofitting can bring them all to an identical state.

### **3.3.5. Safety**

This item shall meet all applicable NSF and other Federal safety regulations, plus those applicable State, Local and LIGO safety requirements. A hazard/risk analysis shall be conducted in accordance with guidelines set forth in the LIGO Project System Safety Management Plan LIGO-M950046-F, section 3.3.2.

The laser beams used in the Optlev will require eye safety considerations during installation and alignment. During normal operation, all Optlev beams are contained within the vacuum or Optlev units.

### **3.3.6. Human Engineering**

Remote control of the coarse alignment of the Optical Levers to be facilitated by a simple hand-held device with a joystick-like control.

## **3.4. Documentation**

### **3.4.1. Specifications**

Specifications to be given in **LIGO-T950112-00-D** ASC Optical Lever Specifications and Conceptual Design

### **3.4.2. Design Documents**

TBD

### **3.4.3. Engineering Drawings and Associated Lists**

Naming and interface cartoons are found in **LIGO-T950070-00-D** Naming Convention and Interface Definition for Optical Lever.

### **3.4.4. Technical Manuals and Procedures**

#### **3.4.4.1 Procedures**

Procedures shall be provided for both electrical and optical alignment:

- Initial installation and setup of equipment
- Normal operation of equipment
- Normal and/or preventative maintenance
- Troubleshooting guide for any anticipated potential malfunctions

#### **3.4.4.2 Manuals**

Drawings of the Optlev mechanical, electronic, and software systems shall be provided to be used with the Procedures above.

### **3.4.5. Documentation Numbering**

All documents shall be numbered and identified in accordance with the LIGO documentation control numbering system LIGO document TBD.

### **3.4.6. Test Plans and Procedures**

All test plans and procedures shall be developed in accordance with the LIGO Test Plan Guidelines, LIGO document TBD.

### 3.5. Logistics

The design shall include a list of all recommended spare parts and special test equipment required.

### 3.6. Precedence

This section lists the relative importance of requirements (or goals) to be achieved by the design. From the most important to the least important, we have

- System noise 10 Hz-10 kHz
- System noise 0.002-10 Hz
- Baseline
- Dynamic range
- Beam size
- Wavelength

### 3.7. Qualification

Test and acceptance criteria: The Optical Lever system shall be tested to meet its specifications in testable subunits before being shipped from the LIGO campus (east/west) to the sites.

## 4 QUALITY ASSURANCE PROVISIONS

### 4.1. General

Every component of every Optical Lever system should be tested to meet its requirements in testable subunits before being shipped from the LIGO campus (east/west) to the sites. The test program shall be developed to ensure that a complete Optlev assembled of tested subunits will meet the requirements for Optlev performance.

**Light Source Testing:** There shall be an installation which has all of the components external to the light source for testing light sources. It shall have a folded and/or evacuated path, as needed, to emulate the baseline without corrupting the measurement. There will be a spatial beam characterization instrument (e.g., Spiricon) which samples the output light at the (virtual) position of the measurement and reference detectors. The Intensity monitor is considered part of the light source, and will be tested *in situ*. Each light source will be placed in this test setup and will be verified to be functioning correctly, i.e., that it meets the specifications. Parameters such as the following will be verified (this list is not exhaustive):

- output beam adjustment
- output beam quality
- tilting mirror functioning

- connector loss and optical quality
- crude vibration sensitivity

**Laser Diode, fiber, and power supply:** There shall be an installation which supplies input power to the laser diode power supply and a receiver photodiode with a fiber connector which mates with the output end of the fiber. Each laser diode will be placed in this test setup and will be verified to be functioning correctly, i.e., that it meets the specifications. Parameters such as the following will be verified (this list is not exhaustive):

- output power
- output stability for constant current
- AM noise from 0.002 Hz to 10 kHz
- intensity controller input: slope and offset

There shall be an installation consisting of a collimated laser diode beam adjustable to beam diameters expected on the measurement and reference detectors, and the VME equipment designed to interface to the photodiodes. The photodiodes or the laser beam shall be translatable across the full diameter of the photodiode. Cables (or equivalent loads) representing real-life will be used. Parameters such as the following will be verified:

- gain in V/mW for each quadrant
- linearity over full range
- behavior under saturation
- noise with no light

Each electrical subunit (X-Y processor, buffer/line drivers, servo amplifier, tilting mirror driver, intensity controller) will be tested to meet its electrical specifications, under realistic loads and driving real-world cables (or equivalent).

#### **4.1.1. Responsibility for Tests**

The light source, laser diode, and quadrant diodes shall be tested by the ASC Optlev responsible engineer or his delegate; the electronic modules shall be tested by the CDS.

#### **4.1.2. Special Tests**

##### **4.1.2.1 Engineering Tests**

A prototype unit shall be tested to meet specifications, and to determine the extent to which it exceeds specifications, before the Final Design Review.

#### **4.1.2.2 Reliability Testing**

Reliability evaluation/development tests shall be conducted on items with limited reliability history that will have a significant impact upon the operational availability of the system.

#### **4.1.3. Configuration Management**

Configuration control of specifications and designs shall be in accordance with the LIGO Detector Implementation Plan.

### **4.2. Quality conformance inspections**

TBD.

## **5 PREPARATION FOR DELIVERY**

### **5.1. Preparation**

Equipment shall be appropriately prepared. For example, vacuum components shall be prepared to prevent contamination.

### **5.2. Packaging**

Procedures for packaging shall ensure cleaning, drying, and preservation methods adequate to prevent deterioration, appropriate protective wrapping, adequate package cushioning, and proper containers. Proper protection shall be provided for shipping loads and environmental stress during transportation, hauling and storage.

### **5.3. Marking**

Appropriate identification of the product, both on packages and shipping containers; all markings necessary for delivery and for storage, if applicable; all markings required by regulations, statutes, and common carriers; and all markings necessary for safety and safe delivery shall be provided.

## **6 NOTES**

None at this time.

## **APPENDIX 1**

Appendix 1 contains a table which lists the requirements and the method of testing requirements. Each test is characterized as falling in one of the following categories:

- **Inspection** shall be used to determine conformity with requirements that are neither func-

tional nor qualitative; for example, identification marks.

- **Analysis** may be used for determination of qualitative and quantitative properties and performance of an item by study, calculation and modeling.
- **Demonstration** may be used for determination of qualitative properties and performance of an item and is accomplished by observation. Verification of an item by this method would be accomplished by using the item for the designated design purpose and would require no special test for final proof of performance.
- **Similarity** analysis may be used in lieu of tests when a determination can be made that an item is similar or identical in design to another item that has been previously certified to equivalent or more stringent criteria. Qualification by similarity is subject to Detector management approval.
- **Test** may be used for the determination of quantitative properties and performance of an item by technical means, such as, the use of external resources, such as voltmeters, recorders, and any test equipment necessary for measuring performance. Test equipment used shall be calibrated to the manufacture's specifications and shall have a calibration sticker showing the current calibration status.

<i>Paragraph</i>	<i>Requirement</i>	<i>I</i>	<i>A</i>	<i>D</i>	<i>S</i>	<i>T</i>
3.2.1.1	System Noise, 10Hz-10 kHz					X
3.2.1.2	System Noise, 0.002-10 Hz					X
3.2.1.3	Baseline		X			
3.2.1.4	Dynamic range		X			
3.2.1.5	Beam size					X
<b>Table 6: Quality Conformance Inspections</b>						