

LSC Photodetector Compensation and Test Procedure

LIGO-T010121-05-D

M. Zucker

10/31/01

ABSTRACT

Setup and procedures are given for tuning, power-dependent bias compensation, and testing of LIGO LSC photodetector modules (LIGO-D980454).

WHEN USED AS A TEST CHECKLIST, RECORD UNIT ID HERE
AND ATTACH COMPLETED DOCUMENT TO UNIT TRAVELER:

SERIAL NO. _____
REV. _____
DESIGN FREQ. _____
TEST DATE _____
TESTER _____

WARNING: This procedure requires use of a Class IV infrared LASER.

To proceed you must be a certified LASER OPERATOR at your work site. You must also comply with applicable laboratory, site, and institutional safety regulations. Should any test described herein conflict with such a regulation, the regulation shall take precedence. Consult your site Laser Safety Officer to obtain a work permit before beginning tests involving regulated or restricted lasers.

1 Introduction

The LIGO LSC photodetectors (LIGO-D980454) sense amplitude-modulated laser power at the output ports of the interferometers. The modulation appears at the interferometer's RF operating frequency f_0 (Table 1). At the heart of the detector module is an InGaAs PIN photodiode with an active area 2 mm in diameter (C30642G, initially manufactured by EG&G and later by Perkin Elmer Optoelectronics). The photodiode is reverse biased at 7 to 13 VDC, depending on operating photocurrent (see below).

CAUTION: The protective window has been removed from the photodiode to optimize performance. This leaves the bare semiconductor surface and bond wires exposed. Always cover the beam aperture with an approved plug or Kapton electrical tape whenever the detector is not in use. Observe cleanroom protocols to avoid dust contamination while the aperture is uncovered. Do not place fingers or objects into the beam aperture.

The RF photocurrent readout incorporates two frequency-selective LC stages; a “pass” stage which optimizes the transimpedance and signal-to-noise ratio at the operating frequency, and a “notch” stage which blocks interfering signals at the harmonic (double) of this frequency. These stages must be tuned manually for the intended use. A low-noise UHF operational amplifier (Maxim MAX4107) detects the developed RF potential, amplifies it by 20 dB and drives a 50 ohm coaxial cable leading to the demodulation electronics, which are housed separately in a relay rack. The DC photocurrent is detected separately by a small fixed transimpedance resistor, and then amplified by another operational amplifier circuit for external monitoring.

LSC photodetectors also incorporate a bias compensation circuit which permits precise cancellation of variations in diode electrical properties as a function of average photocurrent. In LIGO the laser power falling each detector may vary by two orders of magnitude or more during lock acquisition; to maintain an appropriate readout, the magnitude and phase of the detector’s transimpedance must be held constant over this dynamic range. This is accomplished by adjusting the reverse bias voltage across the photodiode in proportion to the instantaneous value of the DC photocurrent. This controls the junction capacitance of the diode, stabilizing the tuning of the frequency-selective LC stages. The proportionality constant varies from diode to diode (it is mostly related to the ohmic contact resistance and depletion layer depth). It must be empirically determined for each module initially and again whenever the photodiode is replaced; a resistor (R21) on the PC board is selected to match each diode properly.

In addition to testing for nominal operation, certain other measurements are required for calibration and interpretation of interferometer signals. These include the RF transimpedance, harmonic notch depth, quantum efficiency, resonance width, and noise level.

interferometer	MC reflection	Main
H2k	27.2 MHz	29.5 MHz
H4k		24.5 MHz
L4k		24.5 MHz

Table 1: LIGO length sensing and control (LSC) operating frequencies

2 Test Equipment and Configuration

2.1 Required Equipment and Test Setup

In addition to standard optical and electronic lab equipment, such as IR mirrors, lenses, mounts, SMA and other RF connectors, and mounting hardware, the following special-purpose apparatus will be needed. The arrangement is depicted schematically in Figure 1. The core component is the electrooptic amplitude modulator. This type of modulator works indirectly by retarding the optical phase of one polarization component in the beam passing through it. By initially presenting the modulator with circularly polarized light (prepared by the quarter wave plate), a varying electrical signal thus causes varying degrees of elliptical polarization to appear at the modulator’s output. A

linear polarizer then transmits proportionately more or less of this output than the nominal 50% expected for a neutral circularly-polarized input state. The complementary fraction is directed to a beam dump. Electrically, the modulator is capacitive; an

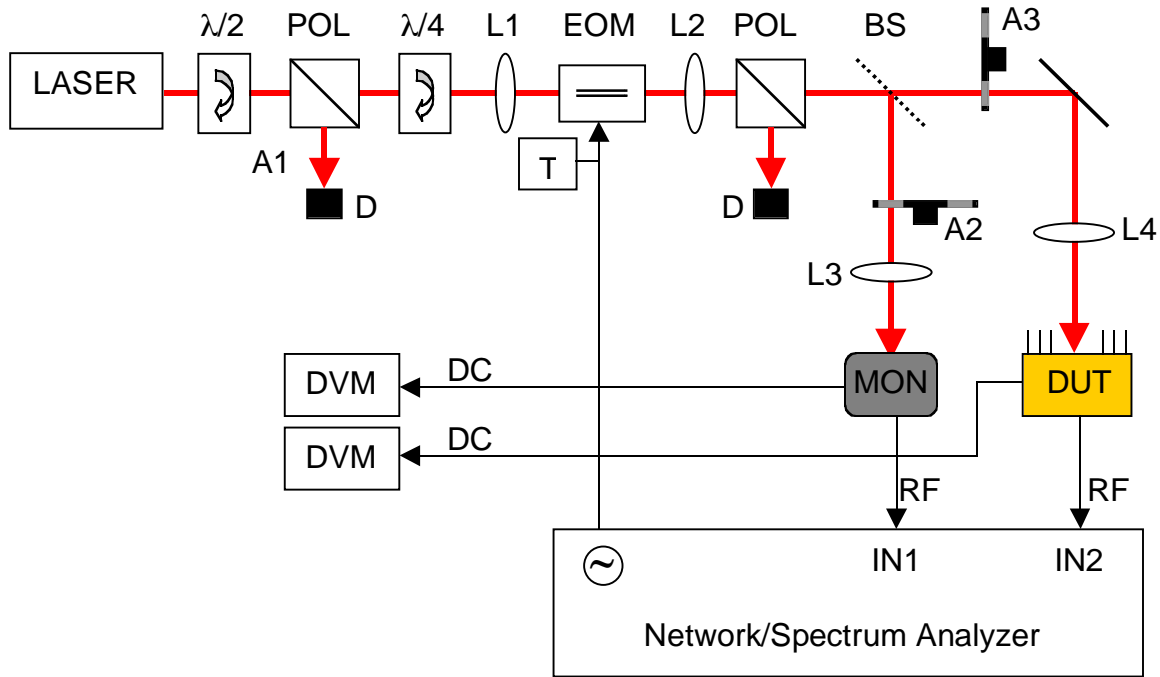

KEY: $\lambda/2$, half wave plate; $\lambda/4$, quarter wave plate; POL, calcite polarizer; D, beam dump; L1- L4, convex lenses (as needed to match beam to aperture or active area); T, 50 Ω RF terminator; EOM, electrooptic amplitude modulator; BS, beam sampler; A1, laser power attenuator assembly; A2- A3, neutral density step attenuators; DVM, digital voltmeter; MON, monitor photodetector; DUT, device under test. Power meter, laser power supply and photodetector power supplies omitted for clarity.

impedance-matching terminator must be added to prevent line loading and reflection effects.

2.1.1 Laser

A Lightwave model 126 or equivalent is required, $P > 400$ mW TEM₀₀ CW in a single-longitudinal mode at 1064 nm wavelength.

2.1.2 Continuously variable high-power attenuator

To maintain consistent beam quality it is best to leave the laser current at a fixed value after it warms up and adjust power with an attenuator. A quartz zero-order halfwave plate polarization rotator, followed by a calcite polarizer and beam dump, make an effective power adjuster.

2.1.3 Network/Spectrum analyzer

An HP 4195A or modern equivalent is recommended. Network analysis mode should accommodate test frequencies between 10 and 100 MHz; internal source output should be selectable between -20 dBm and +10 dBm. In spectrum analysis mode, the front end noise power spectral density should be less than -147 dBm/Hz into 50 ohms (voltage spectral density less than 10 nV/Hz^{1/2}). A spectrum averaging function is useful (the HP 4195A lacks this feature, but it can be added by user programming; contact M. Zucker for software).

2.1.4 Wideband oscilloscope

Tektronix 2245 or equivalent. 2 mV/div minimum vertical sensitivity, 50 ns/div horizontal timebase required.

2.1.5 Electrooptic modulator

New Focus model 4104 LiNbO₄ IR amplitude modulator. (A New Focus model 9071 alignment stage is recommended to aid alignment of this unit. A user-supplied zero-order quartz quarter wave plate and high-quality calcite polarizer are also needed to make the modulator work.)

2.1.6 Neutral density step attenuators

Two New Focus model 5215 neutral density attenuator wheels or equivalent (steps of 0.5 OD, i.e. approximate factors of three in power transmission, are recommended).

2.1.7 Monitor photodetector and power supply

A New Focus model 1811 detector is recommended. The associated 911 power supply is convenient if available.

2.1.8 Laser power meter

An Ophir NOVA with PD-300-3W silicon detector head or equivalent is recommended (power handling and measurement capacity should be at least 1 Watt CW at 1 mm beam diameter, with resolution down to approximately 100 μ Watts.)

2.1.9 Video camera and monitor

The Watec WAT-902 HS monochrome camera, equipped with a fast, close-focusing lens (such as a Computar H6Z0812 zoom) and a quality monochrome video monitor, will aid centering the beam on the test and monitor photodiodes. It also helps to assure repeatable placement of the beam on the power meter sensor.

2.1.10 DUT power supply

An Agilent model E3630 or equivalent triple-output supply is satisfactory (independent 0-6V variable output is required for V_c test; balanced $\pm 15V$ @ 0-500 mA required for DUT power; front panel current and voltage readouts are helpful). A DB-15 to banana or pigtail adapter cable should be built according to the circuit diagram, D980454.

WARNING: The photodetector module is *NOT* protected against reverse power or asymmetrical supplies. Check pinouts and wiring twice before applying power!

2.1.11 Digital voltmeter (DVM)

Fluke model 77 or equivalent. A 5-6 digit bench DVM is also useful for monitoring of the DC output voltage, especially during the incandescent lamp test.

2.1.12 Surface-mount PC board soldering/desoldering equipment

Required for power-dependent bias compensation adjustment (R21 change) and/or board repairs.

3 Test Procedures

3.1 Normal Operation and Initial Tuning

This procedure verifies basic operation and RF tuning. Much of this (other than the laser DC responsivity) can be done without a Class IV laser, and is usually completed before the unit leaves the assembly bench (see LIGO-T010118), but it's a good idea to verify the unit has not been damaged or "evolved" before investing too much in advanced procedures.

3.1.1 Setup

3.1.1.1 Insure laser path is blocked initially; turn on laser and electronic test equipment and allow to warm up to operating temperature per manufacturer's recommendations.

3.1.1.2 Mount DUT in test frame.

3.1.1.3 Connect SMA DC, SMA RF and DB-15 power/aux cables.

3.1.2 Power up checks:

3.1.2.1 Measure +15V supply current draw (power supply ammeter)

_____ **ACCEPTANCE CRITERION:** $70 \text{ mA} < +15V \text{ supply current} < 110 \text{ mA}$ (TBR)

3.1.2.2 Measure -15V supply current draw (power supply ammeter)

_____ **ACCEPTANCE CRITERION:** $30 \text{ mA} < -15V \text{ supply current} < 60 \text{ mA}$ (TBR)

3.1.2.3 Measure DC output “dark” voltage (DVM)

RESULT

ACCEPTANCE CRITERION: $-5 \text{ mV} < V_{DC} (\text{dark}) < 5 \text{ mV}$

NOTE: Check to see that room lights or equipment illuminators are not inducing more than 1 mV of DC response, by temporarily shutting them off or blocking the DUT. If room lights are a problem, it’s preferable for safety reasons to shield the DUT aperture locally, rather than work in the dark. Dilated pupils greatly enhance the danger of laser-induced eye damage.

NOTE: The device draws unequal currents from the positive and negative power supplies, about 50 mA difference under quiescent conditions with the imbalance growing as light power is increased. This floats the circuit ground plane slightly positive with respect to the power supply common, due to the finite resistance of the power common return lead. For example, 0.1Ω common lead resistance produces about 5 mV of offset. Always monitor the DC output voltage using a floated (or differential) DVM connected to the SMA DC output connector. Do not monitor at the end of the DB-15 multi-pin umbilical.

3.1.2.4 Check for oscillation on DC output (wideband scope, RF spectrum analyzer)

ACCEPTANCE CRITERION: No detectable oscillation at 5 mV/div sensitivity on 150 MHz analog or 500 MS/s digital scope.

3.1.2.5 Check for oscillation on RF output (wideband scope, RF spectrum analyzer)

ACCEPTANCE CRITERION: No detectable oscillation at 5 mV/div sensitivity on 150 MHz analog or 500 MS/s digital scope.

NOTE: small ($< 10 \text{ mV p-p}$) oscillatory signals could be caused by external RFI or power supply interactions; check RFI immunity of test setup and environmental conditions before concluding the DUT is malfunctioning.

3.1.3 RF transfer function test

3.1.3.1 Place power meter in front of DUT.

3.1.3.2 Adjust laser controller and attenuator A1 to give approximately $(120\pm 20) \text{ mW}$ onto power meter with *minimum* attenuation (e.g., OD 0 or OD 0.04) selected on attenuator A3. Now leave A1 alone and increase attenuation on A3 until power to DUT is reduced to $(3\pm 2) \text{ mW}$. Record actual power.

RESULT

3.1.3.3 Move power meter in front of monitor diode. Set attenuator A2 to give (1.0 ± 0.5) mW on monitor diode. Record actual power.

_____ RESULT

3.1.3.4 Verify beam is centered and fully captured on active areas of both monitor diode and DUT (using video camera). Record DC outputs of monitor and DUT.

_____ RESULT

_____ RESULT

3.1.3.5 Verify that DUT DC output corresponds to reasonable responsivity, nominally 0.7-0.75 A/W. The responsivity is given by $R_{DC} = I_{DC}/P = V_{DC}/(Z_{DC} P)$ where Z_{DC} is the DC readout transimpedance (nominally 50.1 ohms unless otherwise marked on unit or documentation). Responsivity will be characterized in detail later, so this is just a preliminary check to see if it's worth proceeding.

_____ RESULT

3.1.3.6 Set network analyzer source to 0 dBm driving modulator; sweep transfer function between monitor photodiode (New Focus 1811 or equiv.) and DUT around f_0 . Record the frequency and magnitude of peak response. Required resolution is ± 50 kHz. (network analyzer).

_____ RESULT

_____ RESULT

3.1.3.7 Sweep transfer function around $2f_0$; record frequency and magnitude of notch. Required resolution is ± 50 kHz (network analyzer). Calculate and record the relative gain at $2f_0$ with respect to that at f_0 .

_____ RESULT

NOTE: Depending on the network analyzer noise, you might need to increase the source drive level to achieve sufficient SNR to map out the bottom of the $2f_0$ notch. Do not change optical attenuations or beam alignment into the monitor detector or the DUT between the two measurements, as this will falsely affect the apparent ratio.

NOTE: Parasitic piezoelectric resonances in the amplitude modulator may produce narrow "spike" features at fixed spots in the transfer function which are unrelated to the DUT response. These resonances typically produce beam angle modulation, which affects the monitor and DUT differently (depending on how well centered the beam is on each detector's active area).

Often the spikes can be reduced substantially by tweaking up the beam focus and alignment on both monitor and DUT photodiodes. However, it will generally be necessary to live with a few wrinkles.

Faced with an unfortunate coincidence between such a resonance and f_0 or $2f_0$, one may ultimately need to exchange the modulator for a different one to get reliable test data at those frequencies. Be sure to label such a modulator with its “bad” resonant frequencies as a courtesy to the next user.

3.1.4 Retune passband and notch as required

- 3.1.4.1 Remove the back plate of the DUT (don't lose the screws!)
- 3.1.4.2 Carefully remove the plated steel internal RF cage cover (try not to put excessive stress on the PC board, cage feedthrough capacitors, or SMA connectors; they are delicate). This will expose the active circuit components.
- 3.1.4.3 Set the network analyzer to “manual” or “fixed” scan at $2f_0$. If a fixed-frequency test mode is unavailable, use a rapid repetitive scan over a limited band around $2f_0$. Set a cursor to read out the running magnitude at that frequency point.
- 3.1.4.4 Locate C34 on the internal PC board. Using an INSULATING NONMAGNETIC screwdriver (preferably all plastic), adjust C34 to MINIMIZE the magnitude of the response at $2f_0$.
- 3.1.4.5 Reset the network analyzer test frequency and/or cursor readout to f_0 .
- 3.1.4.6 Locate L5 on the internal PC board. Using an INSULATING NONMAGNETIC screwdriver (preferably all plastic), adjust L5 to MAXIMIZE the magnitude of the response at f_0 .

HINT: For the final tweak it may be more accurate to insure that the response tails cross some given magnitude threshold, say 3 or 6 dB below the peak, at symmetric points above and below the tuning frequency. Some network analyzers have cursor modes that make this method very convenient.

NOTE: If either frequency is found to be beyond the available tuning range of its control, then STOP. In particular, take care not to damage L5 by running the ferrite tuning slug all the way in (it will strip the threads or crack) or out (it will fall out of the can). Consult with the cognizant design engineer to determine the best component exchange for retuning the unit.

3.1.4.7 Iterate the previous four steps until the f_0 response is maximized and the $2f_0$ response is minimized *simultaneously*. Usually no more than two iterations are required; extended hunting may be symptomatic of a bad component or board.

3.1.4.8 Record new response data as in 3.1.3.6 and 3.1.3.7 above.

_____RESULT
_____RESULT
_____RESULT

3.1.5 Data reduction and acceptance criteria

3.1.5.1 Determine the difference between the peak response frequency and design frequency f_0 .

_____RESULT
_____ACCEPTANCE CRITERION: The frequency of peak response shall be within 250 kHz of the design frequency f_0 (TBR).

3.1.5.2 Determine the full-width of the response peak at -3 dB from the peak value

_____RESULT
_____ACCEPTANCE CRITERION: Full-width at -3 dB shall not exceed $0.2 * f_0$ (TBR).

3.1.5.3 Determine and record the ratio between the response at $2f_0$ and f_0 .

_____RESULT
_____ACCEPTANCE CRITERION: The response at $2f_0$ shall not exceed 2% of the response at f_0 (34 dB minimum amplitude ratio) (TBR).

3.1.5.4 If no further internal work is planned, replace the inner RF cage cover gently and recheck the tuning. A significant tuning change due to proximity of the cover (more than 5 kHz or so) may indicate a loose component or bad ground. Otherwise leave it open for the next test phase.

3.2 Bias Compensation Test and Adjustment

3.2.1 Measure tuning deviation vs. laser power

3.2.1.1 Start with f_0 and $2f_0$ responses optimized (3.1 above).

3.2.1.2 Place power meter in front of DUT. Record “dark” DC output of DUT with laser blocked.

_____RESULT

- 3.2.1.3 Adjust laser controller and attenuator A1 to give approximately (120 ± 20) mW onto power meter with *minimum* attenuation (e.g., OD 0 or 0.04) selected on attenuator A3. Place a beam dump in front of DUT.
- 3.2.1.4 Move power meter in front of monitor diode. Set attenuator A2 to give (1.0 ± 0.5) mW. Remove power meter and, if necessary, adjust beam centering and focus on monitor diode active area. Record monitor diode DC output.

RESULT

NOTE: From this point on, do NOT adjust laser or monitor detector power or attenuation; select DUT test power using attenuator A3 only. The idea is to keep the laser, modulator and monitor diode conditions the same throughout and only vary the power reaching on the DUT.

- 3.2.1.5 Set the network analyzer to “manual” or “fixed” scan at the test frequency f_0 or to a narrow frequency range about this point. Set a cursor to read out the magnitude and phase of the response function at f_0 . Set the source level to 0 dBm driving the modulator.
- 3.2.1.6 Move attenuator A3 to maximum attenuation (typically OD 2.5) and remove beam dump such that approximately 0.4 mW will reach DUT. Record the actual power and remove the power meter. If necessary, readjust beam to center on DUT active area.

(Tabulate results from this section in your log; the measurements are to be repeated and used in subsequent calculations)

- 3.2.1.7 Record DUT DC output voltage (DVM) and magnitude and phase of RF transfer function at f_0 (network analyzer).
- 3.2.1.8 Replace power meter in front of DUT and decrease A3 attenuation by one click (assuming steps are OD 0.5 per click, this will increase DUT power by about a factor of three). Record the actual power and remove the power meter.

NOTE: Attenuator ratios are often inaccurate; the exact ratio between steps isn't critical as long as the actual power meter readings are taken at each step. To improve consistency, it's a good idea to insure the power meter always registers on the same part of its sensor area.

- 3.2.1.9 Record DUT DC output, RF magnitude and RF phase.
- 3.2.1.10 Repeat the steps 3.2.1.8 and 3.2.1.9 above, decreasing attenuation at each step until minimum attenuation is reached (corresponding to about 120 mW on the DUT as set in 3.2.1.3).

NOTE: It may be necessary to change electrical input attenuation on the network analyzer to avoid overload at higher power. In extreme cases it may also be necessary to reduce the analyzer source drive level. This

should not affect results if the analyzer is in proper calibration and the monitor photodiode is operating within its linear range.

3.2.2 Reduce data and apply acceptance criteria

3.2.2.1 **DC RESPONSIVITY;** For each power point, compute the DC photocurrent I_{DC} implied by the DC output voltage, using the DC transimpedance Z_{DC} . Calculate the responsivity for each power P using

$$R_{DC} = I_{DC}/P = V_{DC}/(Z_{DC} P)$$

RESULT

ACCEPTANCE CRITERION: $R_{DC} > 0.686$ A/W (TBR)

NOTE: this criterion corresponds to a quantum efficiency $\eta > 0.80$ photoelectrons per photon at 1064 nm wavelength) (TBR). Worst-case effects of power meter calibration (typically $\pm 5\%$) and DC transimpedance tolerance (about $\pm 3\%$) could result in passing a detector with a true η as low as 0.74 electrons/photon. However, tightening the spec to guarantee $\eta > 0.80$ would likely reject many “good” units, since the highest efficiency ever seen is around 0.83. While the transimpedance inaccuracy could be addressed by direct measurement of the electronic components (see below), laser power meters with better than $\pm 5\%$ accuracy are not readily available.

NOTE: Most fielded units have $Z_{DC} = 50.1$ ohms. This should be marked externally on the unit label. If the transimpedance is unknown, inspect the PC board and find components R22A, R22B, R13, and R23. The transimpedance can be calculated (to about $\pm 3\%$, based on 1% resistor tolerances) from

$$Z_{DC} = (R22A+R22B)(R13+R23)/R23 .$$

For $R22A = R22B = 10 \Omega$, $R23 = 267 \Omega$, and $R13 = 402 \Omega$ (current production values), $Z_{DC} = 50.1 \Omega$. Insure the unit label lists the as-built transimpedance and annotate its traveler for future reference.

3.2.2.2 For each power point, convert the RF response magnitude from dB to a numerical ratio $T = V_{RF}(\text{DUT})/V_{RF}(\text{monitor diode})$.

3.2.2.3 **AMPLITUDE FLATNESS;** Divide each RF response T by the corresponding offset-corrected DC output. Subtract the minimum of these RF/DC results from the maximum, and then divide the difference by their mean.

RESULT

_____ **ACCEPTANCE CRITERION:** RF/DC response ratio magnitude should vary by less than 15% peak-to-peak from 0.4 mW to 120 mW (TBR)

3.2.2.4 **RF TRANSIMPEDANCE;** For each power point, form the quantity

$$\begin{aligned} Z_{RF}^{DUT} &= T \cdot \left(\frac{I_{DC}^{MON}}{I_{DC}^{DUT}} \right) Z_{RF}^{MON} \\ &= T \cdot \left(\frac{V_{DC}^{MON}}{V_{DC}^{DUT}} \right) \left(\frac{Z_{DC}^{DUT}}{Z_{DC}^{MON}} \right) Z_{RF}^{MON} \\ &\approx 2.00 \text{ k}\Omega \cdot T \cdot \left(\frac{V_{DC}^{MON}}{V_{DC}^{DUT}} \right) \end{aligned}$$

where Z_{DC}^{DUT} and Z_{DC}^{MON} are the DC transimpedances of the DUT and monitor detector, respectively; V_{DC}^{DUT} and V_{DC}^{MON} are the DC output voltages of the DUT and monitor detector, respectively; and Z_{RF}^{MON} is the RF transimpedance of the monitor detector. In the last line, we have substituted $Z_{DC}^{DUT} = 50.1 \Omega$ (see above), and have used the values $Z_{DC}^{MON} = 1 \text{ k}\Omega$ and $Z_{RF}^{MON} = 40 \text{ k}\Omega$ provided by the manufacturers of the New Focus 1811 monitor photodetector.

Take the mean of these results to form \bar{Z}_{RF}^{DUT} .

_____ **RESULT**

_____ **ACCEPTANCE CRITERION:** $\bar{Z}_{RF}^{DUT} > 2.5 \text{ k}\Omega$

3.2.2.5 **PHASE FLATNESS;** Similarly, find and subtract the minimum RF response phase from the maximum phase.

_____ **RESULT**

_____ **ACCEPTANCE CRITERION:** RF response phase should vary by less than 1.5 degrees peak-to-peak from 0.4 mW to 120 mW (TBR)

NOTE: With no explicit bias compensation, the magnitude ratio may degrade by about 35-40% and the response phase may change by 45 degrees or more over this power range. Achieving these two criteria is the tricky part.

3.2.2.6 If all criteria are satisfied, recheck f_0 and $2f_0$ (notch) tuning as in 3.1.4

NOTE: If tuning is slightly off, retune and then spotcheck the power dependance to make sure it is still within spec. Moderate retuning should not affect amplitude and phase flatness.

3.2.3 Adjust R21 if required: V_C interpolation (Rana's method)

3.2.3.1 If amplitude and/or phase flatness are out of spec, the photocurrent-dependent bias adjustment factor is incorrect and R21 must be replaced. Restore A3 to

maximum attenuation (about 0.4 mW on DUT, 3.2.1.6) and remeasure the transfer function magnitude and phase; record these as reference values.

_____RESULT

_____RESULT

3.2.3.2 Decrease A3 attenuation to bring power on DUT up to the maximum (about 120 mW as before)

3.2.3.3 Monitoring the RF response phase, turn on the V_c bias supply and gradually increase V_c (applied to Pin 3 of DB-15 power/aux connector J3). Do not exceed 10 VDC. Note the applied voltage V'_c where the RF response phase just equals the reference phase noted in step 3.2.3.1. Also note the operating photocurrent I'_{DC} where this match was achieved.

_____RESULT

_____RESULT

3.2.3.4 Look inside and find the existing value of R21. Calculate the revised value R21' using the relation

$$R21' = \left(\frac{V'_c}{I'_{DC} R22 R12} + \frac{1}{R21} \right)^{-1} \quad \text{where}$$
$$R22 \equiv R22A + R22B.$$

- 3.2.3.5 Carefully desolder and remove R21, re-tin and clean the board pads, and solder in a substitute with the value R21' determined above. It may be necessary to use a parallel or series combination of two or more resistors to achieve a value close enough.
- 3.2.3.6 Retest as in 3.2.3.1 above. If flatness is still out of specification, a second iteration of R21 may be required (just reapply the above procedure and formula). If it looks OK, annotate the traveler and label the unit with the final R21 value; repeat the full acceptance test in section 3.2.1.

3.2.4 Adjust R21 if required: quick and dirty (Mike's method)

- 3.2.4.1 Of the first nine diodes compensated, all ended up with a "best" value of R21 between 900 and 1500 ohms. So, check that you're starting out with $R21 = 1.5 \text{ k}\Omega$ (if it didn't come that way from the shop, you might even elect to desolder the existing R21 and solder in $1.5 \text{ k}\Omega$ before testing; it's then easier to solder in a parallel trim resistor to reduce the value precisely if indicated).
- 3.2.4.2 Spot check the flatness as in 3.2.3.1 above. If it looks within spec, you're done; annotate the traveler and label the unit with the final value of R21. Then repeat the full acceptance test in section 3.2.1.
- 3.2.4.3 If the response phase still changes excessively between 0.4 mW and 120 mW, either go through the above calculation (3.2.3.4), or just guess the required adjustment to R21. About 45Ω change in R21 skews the high-power phase by one degree; decreasing R21 tends to increase the high-power phase. Modify R21 and retest as in 3.2.3.1 above.

NOTE: with some experience this will get to the correct value of R21 in one shot.

HINT: if the desired value is less than whatever is now on the board, it is easier and gentler on the PC board to calculate and solder a resistor in parallel rather than desolder the existing one for a complete substitute.

3.3 Noise Testing (*incandescent lamp test*)

NOTE: Testing for noise does not require the laser or monitor photodetector; insert a beamdump or turn the laser off to insure that no laser light is reaching the DUT.

3.3.1 Measure shot noise response

3.3.1.1 Connect DUT RF output to an RF spectrum analyzer (or convert dual-mode network/spectrum analyzer to its spectrum mode, if applicable). Configure the input for minimum noise background. If available, set the analyzer to averaging mode to improve power spectrum estimation accuracy.

3.3.1.2 Measure the voltage power spectral density (VPSD) of the RF output at f_0 with no light on the DUT; call this S_{DARK} .

NOTE: The voltage power spectral density has units of $[V^2/Hz]$. If your analyzer doesn't directly display power spectral densities, be sure to note the reference bandwidth (RBW) setting of the analyzer for each measurement. See Appendix 4 for conversion to/from other noise spectrum conventions.

3.3.1.3 Illuminate the DUT with a DC-powered incandescent lamp, such as a flashlight bulb, to achieve approximately 100-200 mV DC output (about 2-4 mA of photocurrent). Hold this photocurrent as steady as possible until the measurement is complete. Record the power spectral density S_{LAMP} and the DUT DC output voltage V_{LAMP} .

3.3.1.4 Disconnect the DUT from the analyzer and substitute a 50Ω termination resistor; measure the analyzer instrument input noise S_{INST} .

3.3.1.5 Subtract the instrument noise from the dark measurement, $S'_{DARK} = S_{DARK} - S_{INST}$.

3.3.1.6 Subtract the dark noise from the lamp measurement, $S'_{LAMP} = S_{LAMP} - S_{DARK}$.

3.3.1.7 The dark noise intercept photocurrent I_{DNI} is given by

$$I_{DNI} = \frac{V_{LAMP}}{Z_{DC}} \cdot \frac{S'_{DARK}}{S'_{LAMP}} \approx \frac{V_{LAMP}}{50.1\Omega} \cdot \frac{S'_{DARK}}{S'_{LAMP}}$$

ACCEPTANCE CRITERION: $I_{DNI} < 500 \mu A$ (TBR)

NOTE: I_{DNI} can be interpreted as that DC photocurrent which will contribute Poisson (shot) noise equal to the background "dark" noise of the DUT at its operating frequency f_0 . In absolute terms, the current power spectral density of the shot noise itself is given by

$$\tilde{i}_{SHOT}^2 = 2eI_{DC}$$

where e is the electron charge. Therefore the power spectral density of the RF detector output should be

$$S'_{LAMP} = 2e \left(\frac{V_{LAMP}}{Z_{RF}} \right)^2 Z_{RF}^2 = 2e V_{LAMP} Z_{RF}$$

This provides a totally independent measure of the detector's RF transimpedance, which should in principle agree with that found in 3.2.2.4.

NOTE: RF transimpedance values determined in these two independent ways may differ by as much as 25%. The discrepancies exceed expected systematic and random errors for the two methods, and are not currently understood.

4 Appendix: spectral density units

In this document we use power spectral densities (PSD) to quantify noise. This is the electrical noise power delivered to a specified load, generally a 50-ohm matching impedance, falling within a specified frequency bandwidth around the measurement frequency. The basic PSD units are watts per hertz, or [W/Hz]. This unit is inconveniently huge, so often we use milliwatts per hertz instead, [mW/Hz].

The mean square *voltage* noise per unit bandwidth is just the PSD multiplied by the characteristic impedance, and has units of [V²/Hz]. We call this the “voltage power spectral density” or VPSD. (In this document the symbol S is used for VPSD’s.) Similarly, the mean square *current* noise per unit bandwidth, a.k.a. the “current power spectral density” or CPSD, is the PSD divided by the characteristic impedance, and has units of [A²/Hz]. The relation between power and the mean squares of current and voltage also applies to their respective power spectral densities:

$$\text{PSD} = Z \cdot \text{CPSD} = \frac{\text{VPSD}}{Z}$$

where Z is the characteristic impedance.

One way to measure the PSD of an unknown signal at some frequency of interest is to construct a bandpass filter that only transmits signals within a fixed range around the measurement frequency, pass the signal under scrutiny through it, and measure the electrical power delivered at the output. Effectively, this is what spectrum analyzers do (usually at a series of different measurement frequencies, thereby generating a “power spectrum”). The frequency width of the filter (in Hertz) is termed the “Reference Bandwidth” or “Resolution Bandwidth” or just “RBW.”

Many RF analyzers format their readout logarithmically in units of dBm, which is short for “decibels referred to one milliwatt” (usually for RF one assumes a 50 ohm impedance, although there are 75 ohm instruments for cable TV, 600 ohm instruments for audio, and optical power meters which also use dBm). The number K of dBm corresponding to a given power P is

$$K \text{ [dBm]} = 10 \cdot \log_{10} \left(\frac{P}{1 \text{ mW}} \right).$$

For noise, it is necessary to account for reference bandwidth as well as power at each frequency. One convention is to use the unit dBm/Hz. This is “decibels referred to one milliwatt per Hertz PSD.” The number D of dBm/Hz corresponding to a given power spectral density is

$$D \text{ [dBm/Hz]} = 10 \cdot \log_{10} \left(\frac{\text{PSD}}{1 \text{ mW/Hz}} \right).$$

Given a raw measurement K in dBm, the measurement bandwidth RBW, and the characteristic impedance Z , one can form the power and voltage power spectral densities using

$$\text{PSD [mW/Hz]} = \frac{10^{(K [\text{dBm}]/10)}}{\text{RBW[Hz]}} \text{ and}$$

$$\text{VPSD [V}^2\text{/Hz]} = \frac{\text{PSD [mW/Hz]} \cdot Z}{1000} .$$

Noise measurements may also be quoted using the *square root* of the corresponding PSD, CPSD or VPSD. These can be referred to as the “amplitude spectral density,” “current spectral density” or “voltage spectral density” and carry units of $[\sqrt{\text{W/Hz}}]$, $[\text{A}/\sqrt{\text{Hz}}]$ and $[\text{V}/\sqrt{\text{Hz}}]$ respectively. One must square these quantities (revert them to powers) before adding contributions from different sources or rescaling measurement bandwidths; noise powers add linearly, noise voltages and currents do not.

As a reference point, 0 dBm corresponds to a mean-square voltage of 0.05 V^2 or $(224 \text{ mV}_{\text{RMS}})^2$ into 50 ohms, and 0 dBm/Hz corresponds to a VPSD of $0.05 \text{ V}^2\text{/Hz}$ or $(224 \text{ mV}_{\text{RMS}}/\sqrt{\text{Hz}})^2$ into 50 ohms.

5 Appendix: sample data for some tested detectors

The following plots display some results for a sample of production photodetectors.

5.1 RF amplitude and phase flatness vs. photocurrent

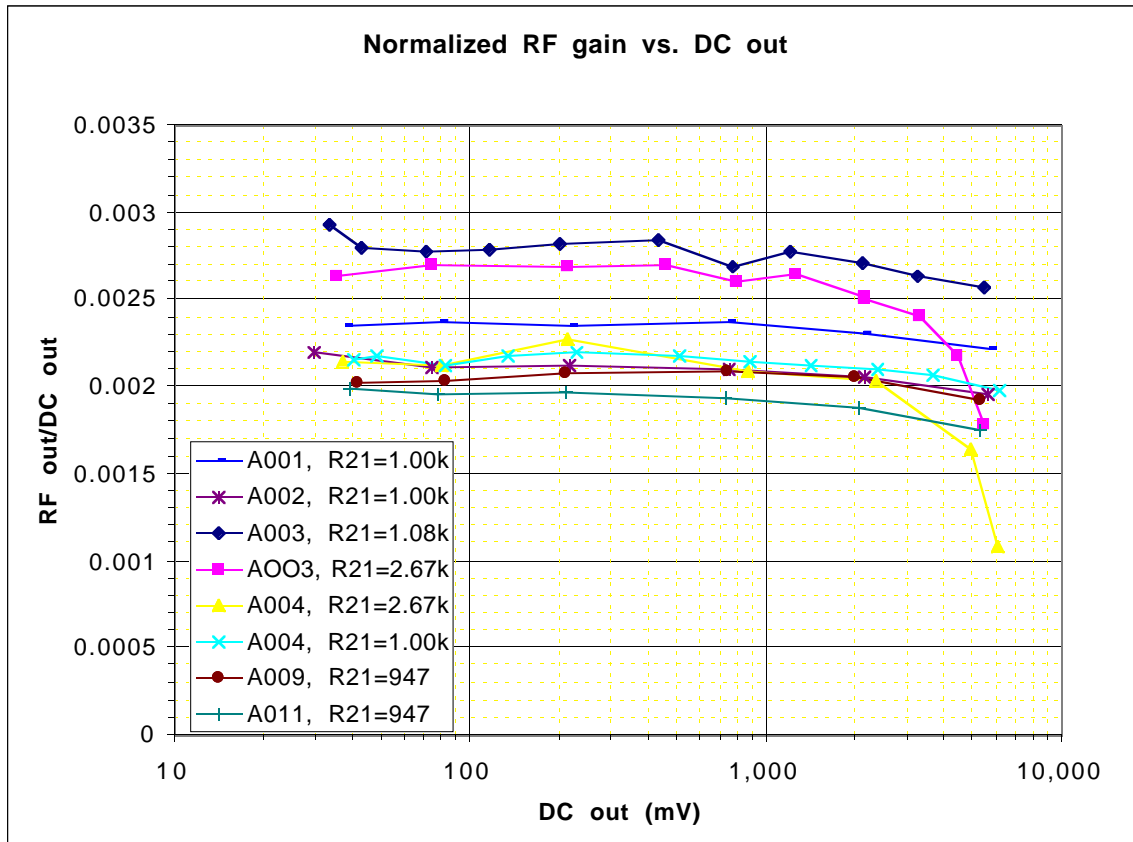

Figure 2: Normalized RF amplitude response vs. power (represented by DC output voltage) for a selection of photodetectors with various values of R21.

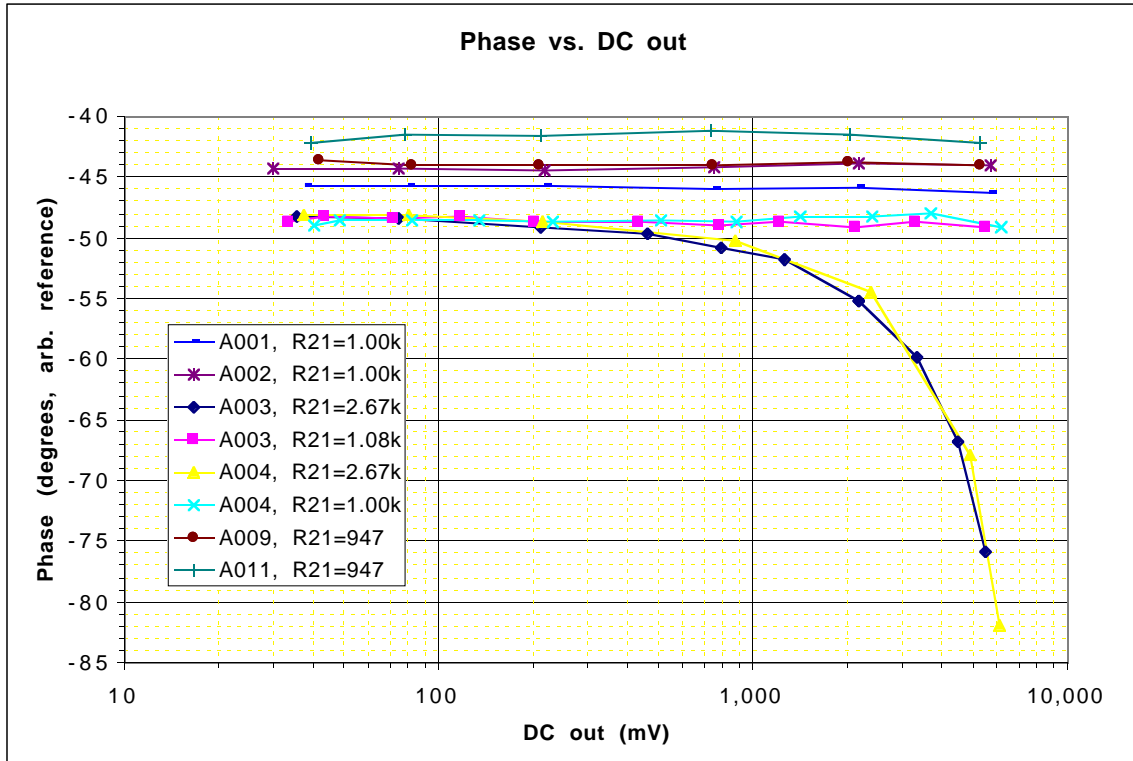

Figure 3: RF response phase vs. power (DC output voltage) for a selection of photodetector modules with various values of R21.

5.2 DC Responsivity

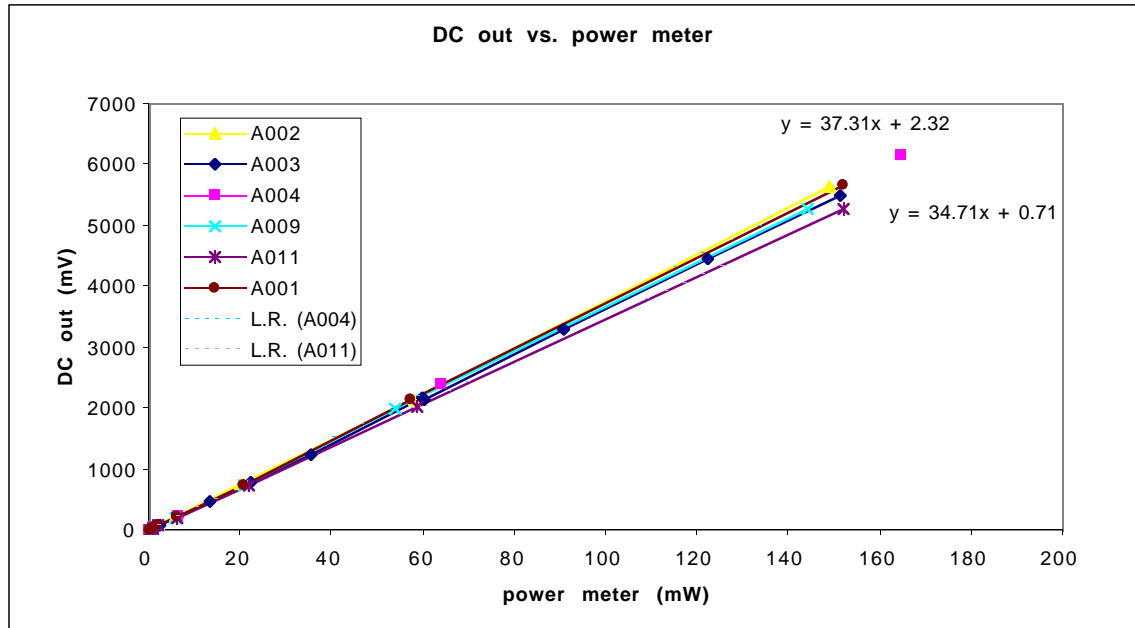

Figure 4: DC output voltage vs. incident power for 5 units. Power is measured with an Ophir NOVA/PDA300-3W power meter. Linear regressions are overplotted for two units to illustrate linearity; given the DC output transimpedance of these particular units (49.4Ω), the slopes imply responsivities of 0.76 and 0.70 A/W respectively.

5.3 RF Noise vs. Laser and Incoherent Lamp Photocurrent

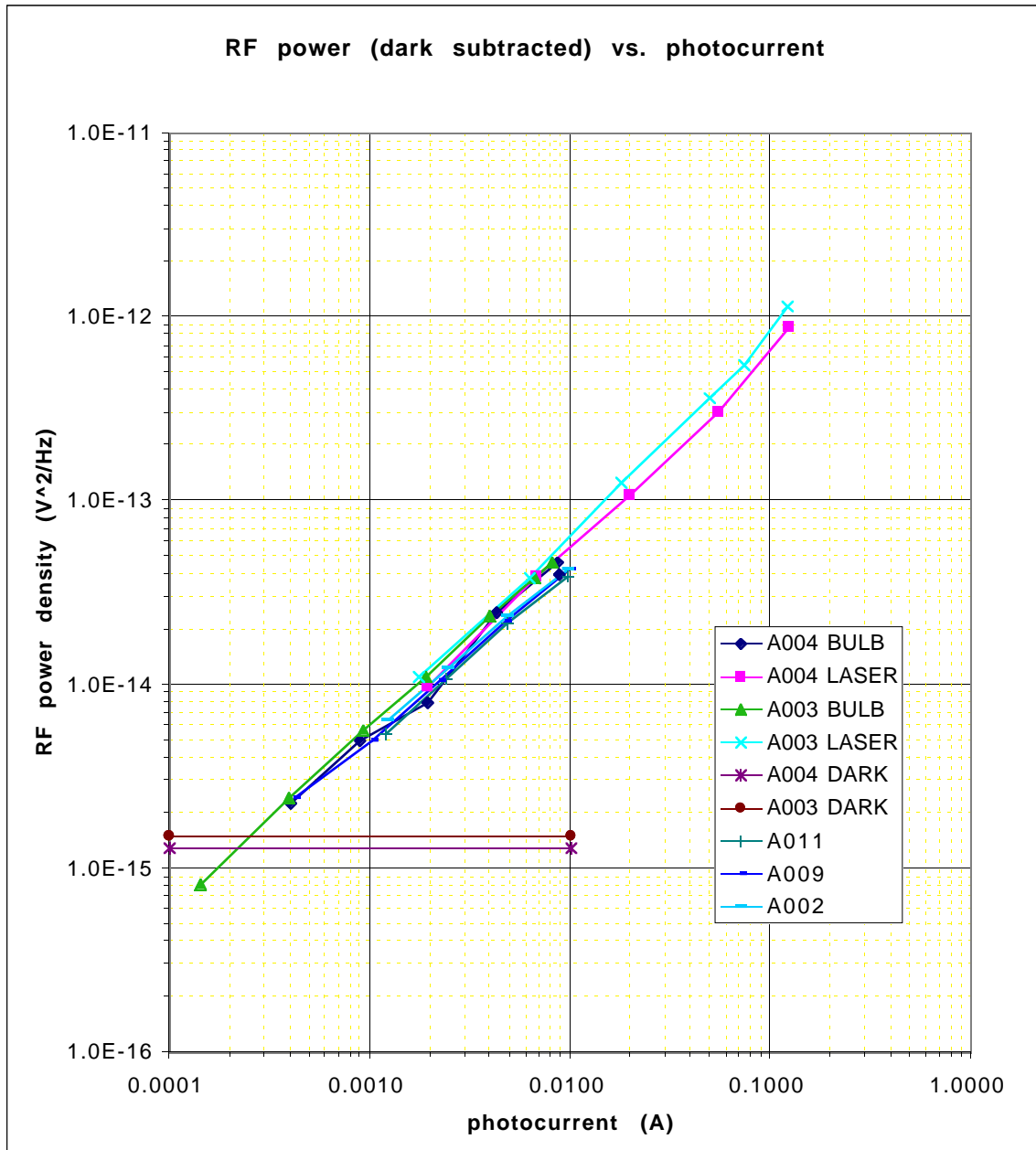

Figure 5: RF noise voltage spectral density vs. photocurrent for 5 units, with incoherent lamp (BULB) and Lightwave 126 laser illumination. Note that with laser illumination the slope deviates from proportionality at high photocurrents, indicating this laser has technical amplitude noise in excess of shot noise at the working frequency (24.5 MHz).

6 Appendix: References

6.1 Acronyms

RF Radio Frequency
AM Amplitude modulation
DUT Device Under Test
MON Monitor photodetector
EOM Electrooptic modulator
DC Direct Current
LSC Length Sensing and Control

6.2 Reference Documents

LIGO-D980454-02-C	LSC Photodiode Electronic Schematic
LIGO-Dxxxxxx-xx-X	LSC Photodiode Case Assembly
LIGO-Dxxxxxx-xx-X	LSC Photodiode Heat Sink and Thermal Block Assembly
LIGO-T010118-00-C	RF Photodiode Functional Test
LIGO-T010138-A-C	EG&G Photodiode Testing and Handling Procedure

7 Appendix: Reference Circuit Schematic

The following is a reprint of D980454-03-C, recorded 1/7/00. It is included only for context reference to help follow the text; always obtain and refer to the applicable schematic revision, update level and as-built traveler documentation for the specific unit under test. These are semi-custom modules with numerous application-specific component variations.

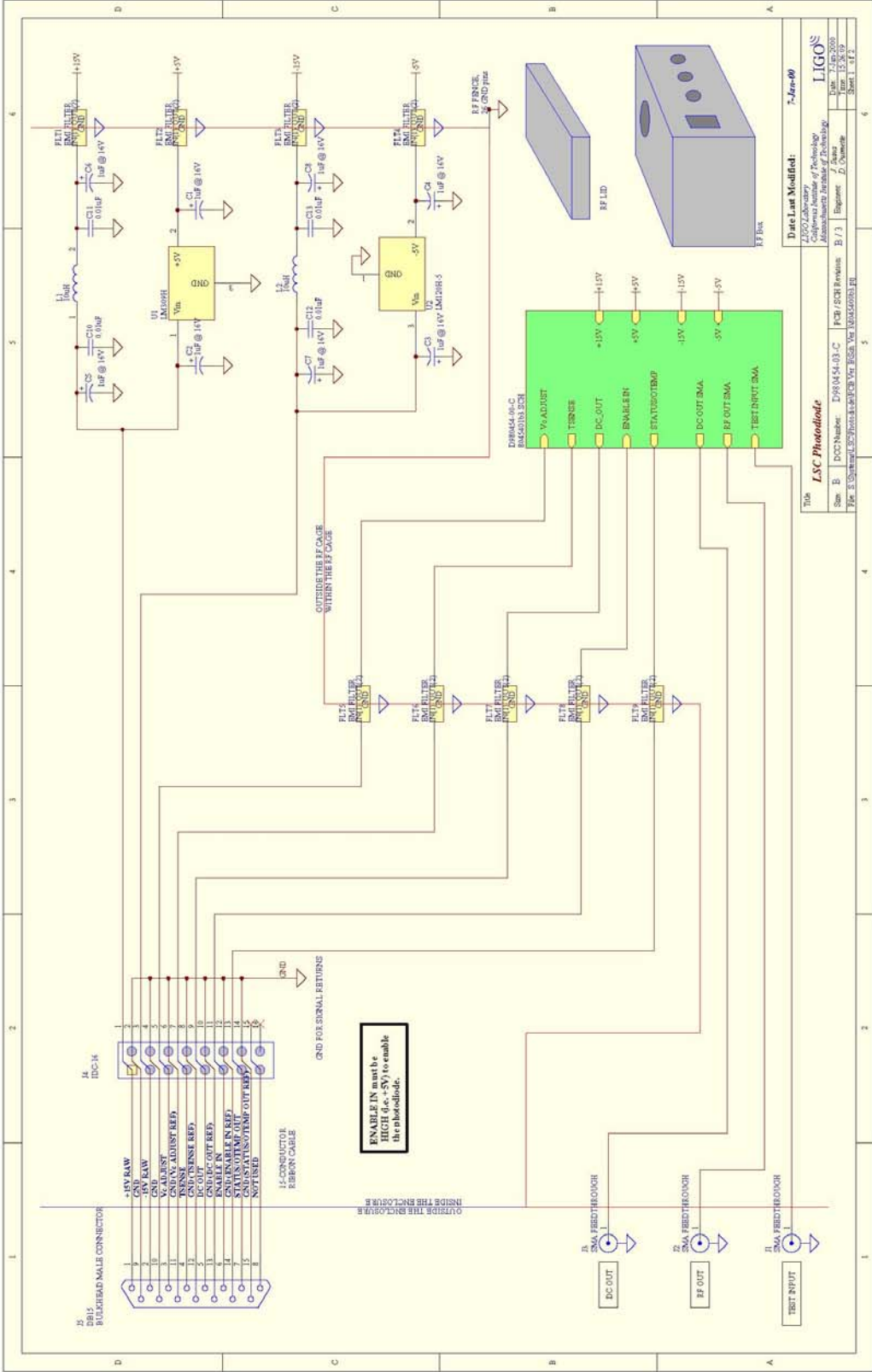

Date Last Modified: 7-Jan-00	
LJCOO/Library	
California Institute of Technology	
Advanced Research Laboratory	
Doc Number: D99044-03-C	Rev / CTR revision: B / 1
Rev: B	Page: 2 of 2
For: E:\Schematic\Projects\RF\RF Box V04\RFBox03.DWG	
Title: LSC Photodiode	
Date: 7-Jan-2000	
Time: 15:36:19	
Sheet: 1 of 2	

ENABLE IN must be connected to enable the photodiode.

OUTSIDE THE ENCLOSURE

INSIDE THE ENCLOSURE

12-CONDUCTOR RIBBON CABLE

GND FOR SIGNAL RETURNS

GND

DB15 BULKHEAD MALE CONNECTOR

IDC-14

1 2 3 4 5 6 7 8 9 10 11 12 13 14 15

1 2 3 4 5 6 7 8 9 10 11 12 13 14 15

1 2 3 4 5 6 7 8 9 10 11 12 13 14 15

1 2 3 4 5 6 7 8 9 10 11 12 13 14 15

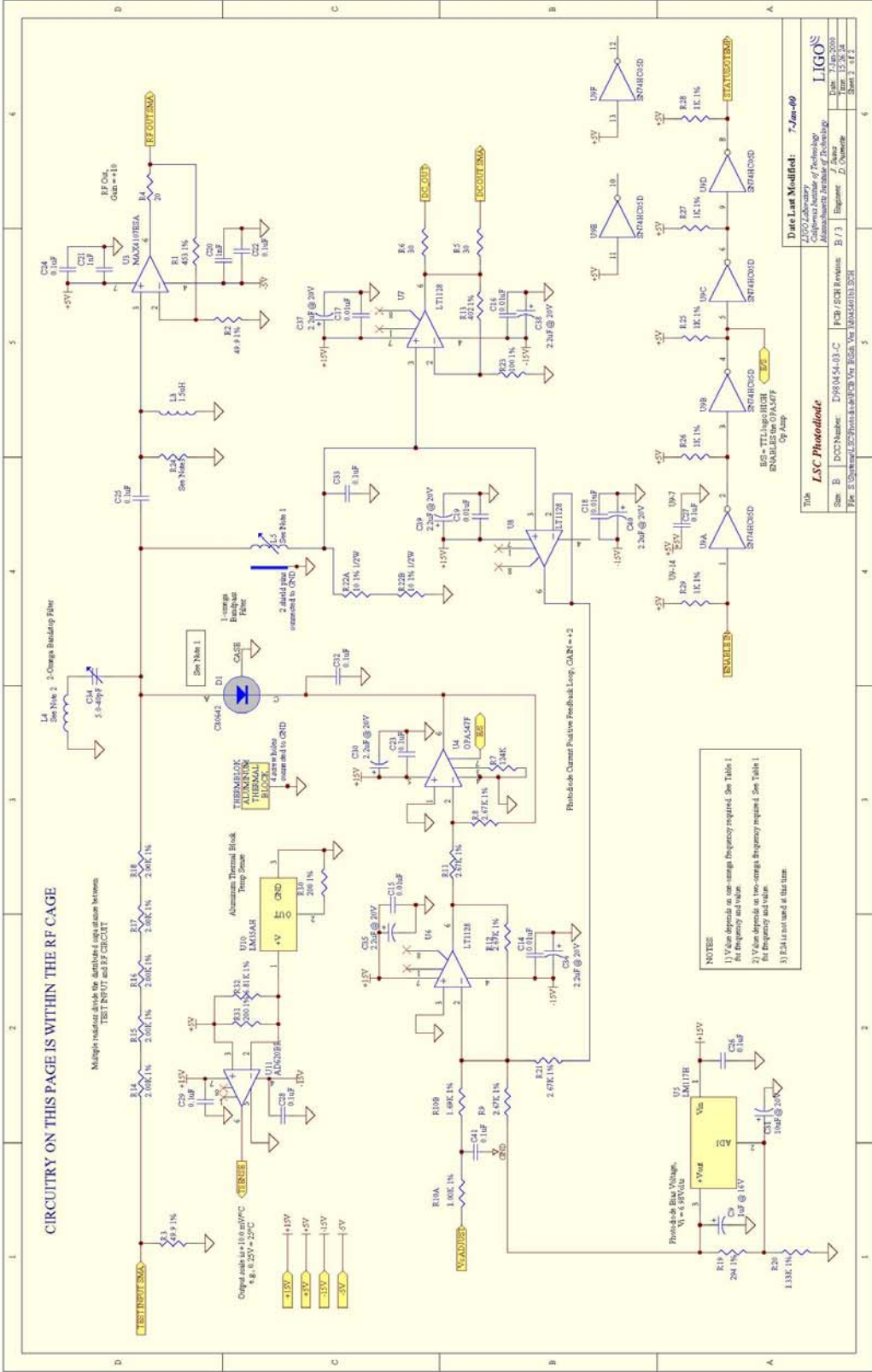

CIRCUITRY ON THIS PAGE IS WITHIN THE RF CAGE

Multiple resistors divide the distributed capacitance between TEST INPUT and RF CIRCUIT

Output levels are +100 mV/C
e.g. +1.25V = 25°C

+15V
-15V
-3.5V
-3V
-0V

NOTES

1) V_{FB} feedback is not always frequency required. See Table 1 for frequency and values.

2) V_{FB} feedback is not always frequency required. See Table 1 for frequency and values.

3) U5A is not used, it is the same.

Title		Date Last Modified: 7-Jan-99	
LSC Photodiode		LJCOO Laboratory	
Doc Number: DFR0454.03.C PCB / PCB Problem: B / 1		California Institute of Technology	
Rev: B		Acquisition Number: 10000000	
For: E:\Schematic\PCB\PCB FOR PDSR V04\RF040303.PCB		Date: 7-Jan-2000	
		Time: 15:26:34	
		Sheet: 7 of 7	