



LIGO Laboratory / LIGO Scientific Collaboration

LIGO-T000035-00-W

ADVANCED LIGO

September 2004

Pre-Stabilized Laser Design Requirements

B. Willke, et al.

Distribution of this document:
LIGO Science Collaboration

This is an internal working note
of the LIGO Project.

California Institute of Technology
LIGO Project – MS 18-34
1200 E. California Blvd.
Pasadena, CA 91125
Phone (626) 395-2129
Fax (626) 304-9834
E-mail: info@ligo.caltech.edu

Massachusetts Institute of Technology
LIGO Project – NW17-161
175 Albany St
Cambridge, MA 02139
Phone (617) 253-4824
Fax (617) 253-7014
E-mail: info@ligo.mit.edu

LIGO Hanford Observatory
P.O. Box 1970
Mail Stop S9-02
Richland WA 99352
Phone 509-372-8106
Fax 509-372-8137

LIGO Livingston Observatory
P.O. Box 940
Livingston, LA 70754
Phone 225-686-3100
Fax 225-686-7189

<http://www.ligo.caltech.edu/>

1 Introduction

1.1 Purpose and general description

The purpose of this document is to define the content of the Advanced LIGO Pre-Stabilized Laser subsystem (PSL), and to give the design requirements for the PSL. The PSL subsystem provides the laser radiation for the LIGO interferometers. The heart of the PSL is the AdvLIGO Laser being developed by Laser Zentrum Hannover (LZH). The goal of the PSL development work is to design a system capable of accommodating the AdvLIGO Laser and reducing its output beam frequency and power fluctuations to the levels required for the AdvLIGO detectors. The PSL subsystem will be capable of remote control and monitoring via computer and will incorporate internal diagnostics as well as features that allow other subsystems to diagnose their performance.

Detector availability requirements that the PSL subsystem acquire lock quickly and reliability and operate without loss of lock for long periods of time. In addition, the PSL must maintain performance while accommodating control signals from the IOO and LSC subsystems that enable other subsystems to achieve required performance.

Designing and fabricating the laser systems with the reliability and maintainability required to enable the detectors to meet availability goals is expected to present a major challenge for the PSL subsystem.

1.2 Scope

The PSL provides the pre-stabilized laser light for the interferometer, via its interface with the Input Optics (IO) subsystem. The PSL includes:

- The high power laser, delivering power to the IO according to the requirements given below; the cooling system for the high power laser is part of the PSL.
- Systems for stabilizing the laser frequency and power to the levels stated below. The PSL *is not* responsible for providing the final level of frequency stability required by the interferometer, only the first, or ‘pre-stabilization’ level. The PSL *is* responsible for providing the final level of power stability required by the interferometer.
- The optical table that holds the PSL and those components of the IO that lie between the PSL output and the point of beam injection into the vacuum system. The optical table support (including any vibration isolation) and table enclosure are also provided by the PSL subsystem.
- Wideband actuation of the laser frequency, to enable additional levels of frequency stabilization.
- Diagnostics and supervisory controls functions, compatible with the CDS EPICS systems; provision of appropriate signals to the interferometer data acquisition (DAQ) system.

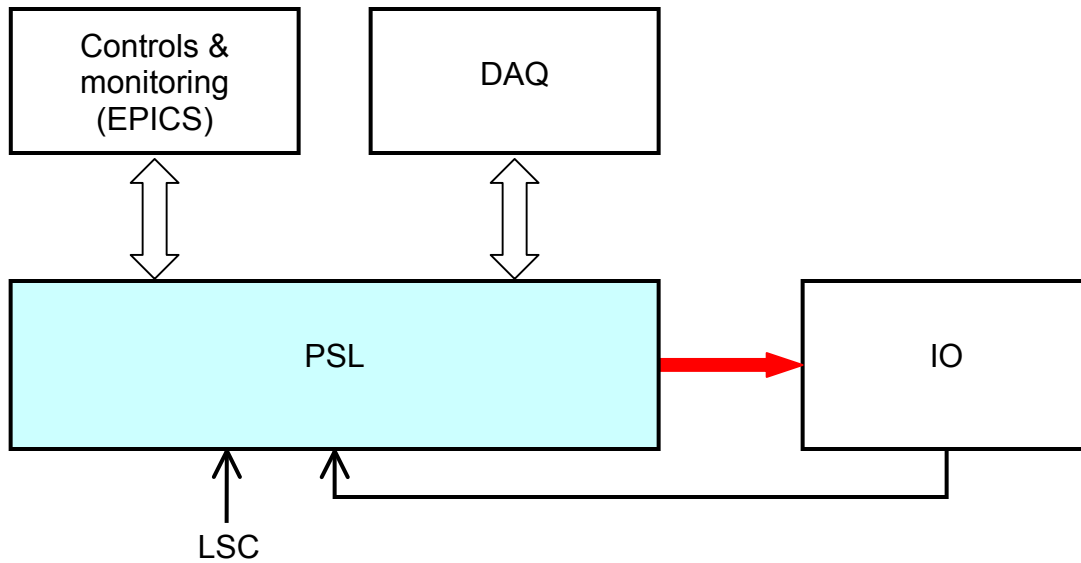

Figure 1. PSL subsystem, showing its relation to the interferometer.

1.3 Constraints, Assumptions and Dependencies

LIGO must operate continuously, therefore this subsystem must be designed with high reliability and low mean-time-to-repair. The PSL subsystem incorporates several feedback control loops that enable the frequency and power of the laser radiation to be stabilized to very low fluctuation levels. Those control loops must acquire lock quickly and reliably via a computer-automated sequence and maintain lock for long periods of time.

As far as they may influence the PSL design, the vibration and acoustic levels in the Laser and Vacuum Equipment Areas (LVEA) at the LIGO observatories should be taken to be those detailed in T010074 (rev. 3 at the time of writing), “*The LIGO Observatory Environment.*”

The temperature and pressure in the LVEA are assumed to meet the design conditions given in the Civil Construction Facilities Design Configuration Control Document, Final Issue, July 3, 1996, LIGO-C960703-0, which specifies a design temperature of $72^{\circ} \pm 3.5^{\circ}\text{F}$ and pressure of 0.15 in. Hg above ambient.

1.4 Applicable Documents

Advanced LIGO Systems Design Document T010075-00

COC Reference Design Document <http://www.ligo.caltech.edu/docs/T/T000098-00>

2 Requirements

2.1 Beam characteristics

Property	Value	Comment
Wavelength	1064 nm	Same as initial LIGO
Fundamental Mode Power	≥ 165 W	At the IO interface, in a circular TEM ₀₀ mode
Higher-order Mode Power	≤ 5 W	
Polarization	Vertical, > 100:1 ratio	At IO interface, pol. to be normal to table surface, to ± 1 deg
Beam size	TBD	At IO interface
Beam height	3 inches	At IO interface, from table surface

Table 1. Specifications for the PSL beam, as delivered to the IO subsystem.

2.2 Laser power stability & noise

Long term stability. The laser power can be stabilized on time scales longer than ~ 10 sec through the interferometer control and monitoring systems (EPICS), using any (or a combination of) the various interferometer power monitors. The PSL is required to provide an appropriate control input to enable such stabilization at a level of 1% peak-to-peak residual fluctuations, over time scales up to 24 hours. The PSL power should also be reasonably stable on its own, exhibiting peak-to-peak power fluctuations less than 5% over any 24 hour period.

Control band fluctuations. The control band is defined as the range 0.1-10 Hz. Good power stability is required in this band to control the fluctuating radiation pressure forces on the suspended optics. The goal is that the radiation pressure-induced optic motion be smaller than the seismically induced motion. The former is estimated as:

$$\delta x \approx \frac{2\delta P}{c} \frac{1}{M\omega_0^2} K,$$

where ω_0 is the lowest eigen-frequency of the suspension, and the factor $K = 1-3$ accounts for the force-to-displacement transfer function of the damped suspension. Radiation pressure motion may be significant for the test masses and mode cleaner mirrors, which sustain high incident power:

Optic	δx	RMS seismic/local damping motion
TM	$6 \times 10^{-11} \cdot \delta P$ (m/W)	~ 0.2 nm ($f > 1$ Hz)
MC	$4 \times 10^{-10} \cdot \delta P$ (m/W)	~ 10 nm ($f > 0.4$ Hz)

Table 2. Optic motion from radiation pressure, assuming $dP(f) = \text{constant}$ in the 0.1-10 Hz band, and $K = 3$. The third column is an estimate of the optic motion, under local damping, due to SEI platform motion and local damping noise.

The nominal incident power is 800 kW for a TM, and 75 kW for a MC mirror, thus in terms of the relative power fluctuations (RIN), the optic motion is $\delta x \sim (3-5) \times 10^{-5} \cdot \text{RIN}$. We set the following requirements on power stability:

Frequency band	RIN requirement (dP-rms/P)	Induced motion
0.4 – 10 Hz	$< 10^{-4}$	$< 3\text{-}5\text{ nm}$
0.1 – 0.4 Hz	$< 10^{-3}$	$< 10\text{-}15\text{ nm}$

Table 3. Power stability requirements in the control band.

Fluctuations at IO interface. TBD (any reason to specify this independently of the next section?)

GW band noise. The PSL power noise requirement at the input to the interferometer, in the GW band, is shown in Figure 2. At frequencies below a few hundred Hertz, the dominant coupling mechanism is technical radiation pressure imbalance in the arm cavities, creating a net differential displacement of the test masses. The PSL power noise requirement assumes an arm cavity average arm power imbalance of 1%. The radiation pressure effect is heavily low-pass filtered optically and mechanically, and at higher frequencies the dominant coupling is directly through the AS port sensing (the DC offset imposed on the differential arm length to produce the homodyne readout). The actual high-frequency limit in Figure 2 is lower than what is expected to be needed (see T010075-00, Advanced LIGO Systems Design), but should be a readily attainable noise level, and provides more margin in the system design.

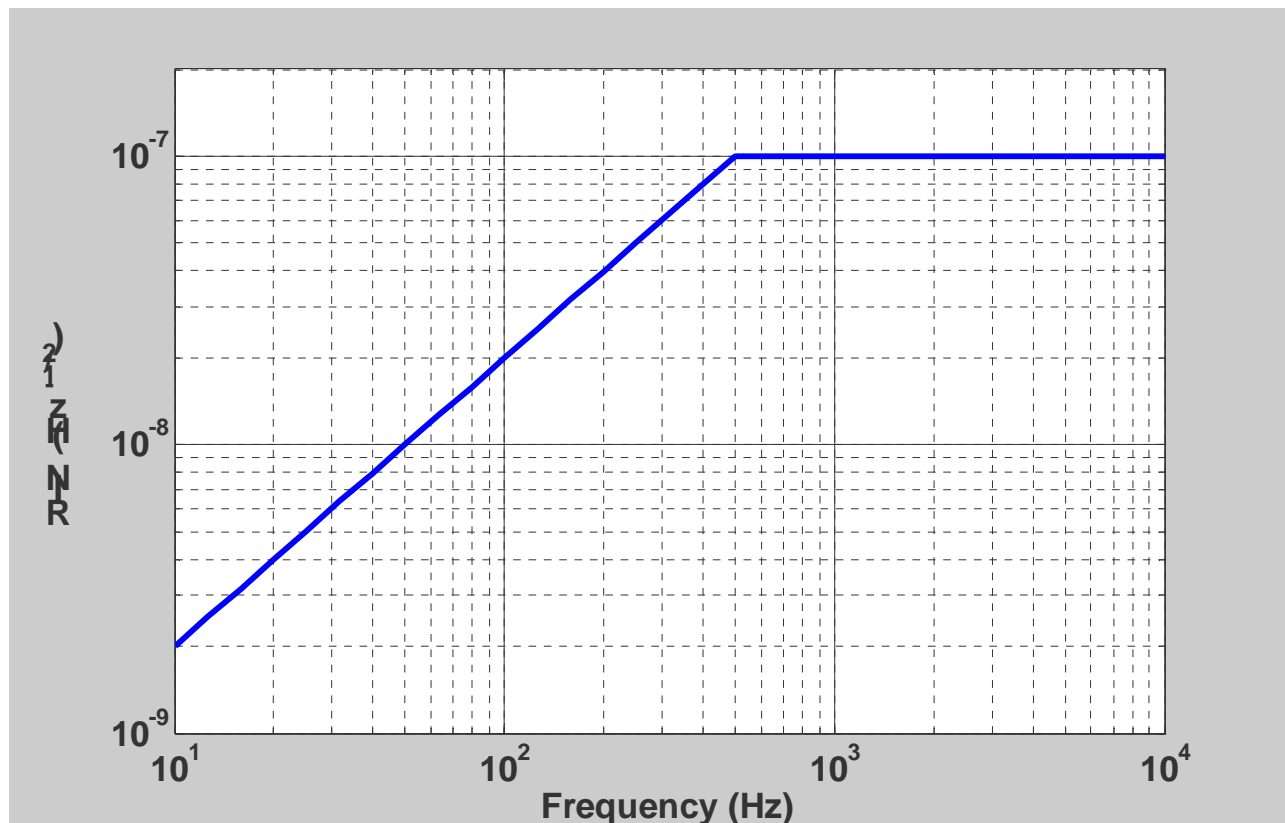

Figure 2. The PSL amplitude (power) spectral noise requirement at the input to the interferometer (power recycling mirror); the requirement is expressed as the relative-intensity-noise density (*RIN*), typically expressed by the symbols: $\delta\tilde{P}(f)/P$.

Amplitude noise in the RF band. The laser amplitude must be close to shot-noise limited at the RF modulation/demodulation frequencies, to maintain low sensing noise in the interferometer auxiliary degrees-of-freedom. *Requirement: for frequencies $f > 9$ MHz, the broadband PSL amplitude noise must be less than 3 dB above the shot-noise in an average photocurrent of 50 ma.* Narrowband signals above this level may be acceptable depending on their exact frequencies.

2.3 Frequency stability & noise

Long term stability. The long term frequency stability should be such that the fractional frequency variations are much smaller than the fractional arm length variations. The latter are principally due to tidal stretching (for time scales longer than of order one minute), with arm length changes up to a few hundred microns. The frequency stability requirement is set to be equivalent to 1 micron of arm length change. *Specifically, for time scales longer than 100sec, the laser frequency must be stable to within 100kHz.*

Control band fluctuations. In the control band (0.1 – 10 Hz), the PSL frequency serves as the reference for interferometer lock acquisition. Therefore, the control band fractional frequency fluctuations must be much smaller than the fractional arm length fluctuations due to seismically driven, locally damped test masses, as follows:

Frequency band	Frequency stability req.	Compared to TM motion
1 – 10 Hz	< 3 Hz-rms	5x lower
0.4 – 1 Hz	< 100 Hz-rms	10x lower
0.1 – 0.4 Hz	< 1000 Hz-rms	10x lower

Table 4. Requirements on the PSL frequency fluctuations in the control band.

GW band frequency noise. The PSL frequency noise requirement in the GW band is shown in Figure 3.

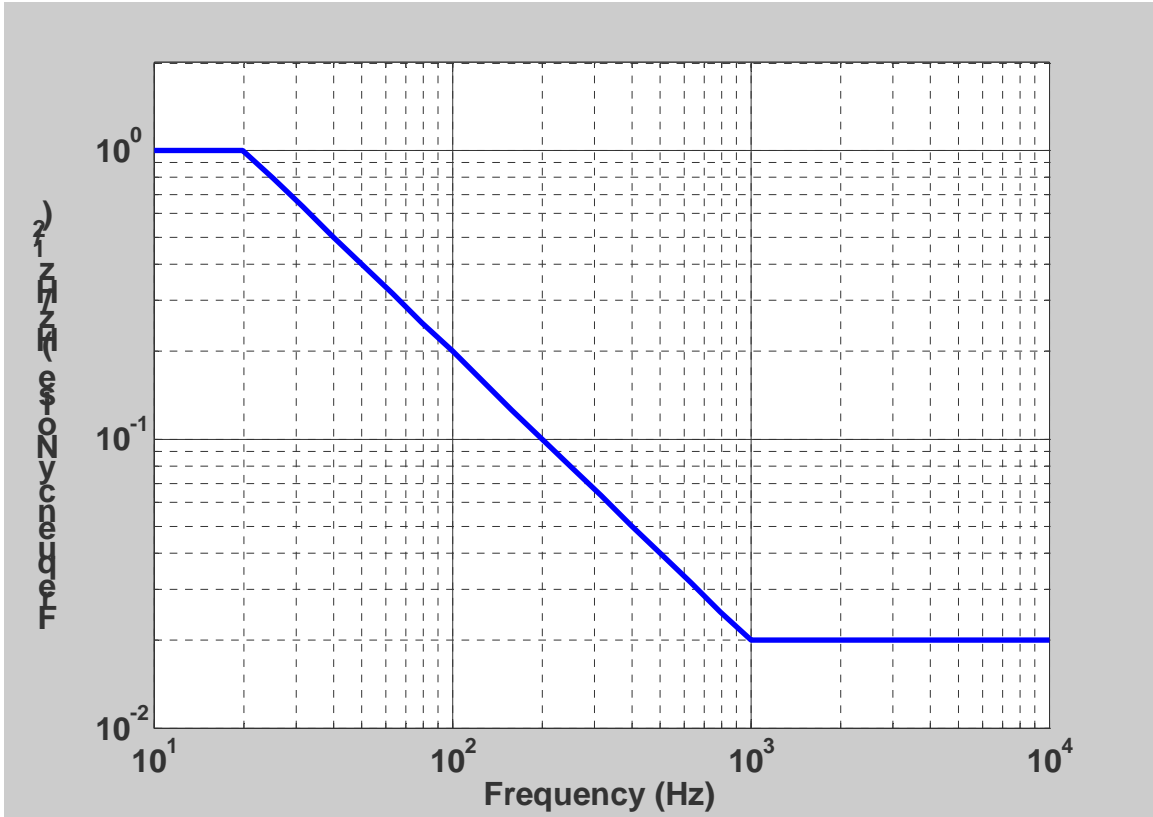

Figure 3. PSL frequency noise requirement in the GW band. See text for explanation.

2.4 Beam pointing stability

The directional stability of the PSL beam, at the IO interface, must be reasonably good, though it is the responsibility of the IO subsystem to deliver the final interferometer input beam pointing stability. For the PSL beam, the directional stability requirement at the IO interface is:

$$\varepsilon_1 < (3 \times 10^{-5} / f) \text{ Hz}^{1/2} \quad f > 10 \text{ Hz}$$

where $\varepsilon_1 = [(\delta\tilde{\alpha}(f)/\theta_D)^2 + (\delta\tilde{x}(f)/\omega_0)^2]^{1/2}$, with $\delta\alpha$ and θ_D being the angle fluctuations and divergence angle of the beam, respectively, and with δx and ω_0 being the translational fluctuations and waist size of the beam, respectively. The above requirement applies to both horizontal and vertical directions.

For longer time scales, the requirement is: $\varepsilon_1 < 0.03$ rms, in the band $f = \text{DC}-10 \text{ Hz}$.

2.5 Frequency control

The PSL must supply two frequency modulation inputs, one being a ‘wideband input’ for fast frequency control, the other being a ‘tidal input’ for slow tracking of the laser frequency to the tidal arm stretching. The requirements for these inputs are essentially the same as for initial LIGO, with some reduction in the required wideband input range. Given the large range of the SEI subsystem’s hydraulic actuators, it could be considered to eliminate the PSL tidal input, and simply correct the arm lengths at all frequencies (rather than having the laser frequency follow the arms at tidal

frequencies). If there is a significant benefit to the PSL in eliminating the tidal input, this can be carefully considered; for now, the tidal input is assumed to be required. The requirements for the two inputs are given in Table 5.

Wideband frequency input	
Bandwidth	100 kHz: less than 20 degrees phase lag at 100 kHz
Range:	DC-1 Hz: 1 MHz pk-pk f > 1 Hz: 10 kHz pk-pk
Tidal frequency input	
	Range: 50 MHz pk-pk Speed: time constant < 20 min

Table 5. Requirements for the PSL frequency control inputs

2.6 Power control

Coarse control of the laser power sent into the interferometer is the responsibility of the Input Optics (IO) subsystem, and the PSL should nominally deliver its full power to the IO interface. However, the PSL is required to provide a small-signal amplitude modulation input, for global diagnostics use. *The modulation input must have a bandwidth of DC-10 kHz (or greater), with a minimum range of $\pm 1\%$ power modulation over this bandwidth.*

2.7 Diagnostics

Diagnostics capability must be included in the PSL design to allow determination of the subsystem's performance. This may be done through a combination of internal PSL diagnostics and interfacing to the Global Diagnostics Subsystem. Some examples of diagnostics that must be supplied:

- Monitoring of laser power levels at key points in the subsystem
- Monitoring of the loop gains of the frequency pre-stabilization and amplitude stabilization servos
- Out-of-loop monitor of the GW band amplitude noise
- Monitoring of the health of the high power laser; e.g., temperature monitors, pump diode I-V and light output monitors, etc.