

An optical vernier technique for *in situ* measurement of the length of long Fabry–Pérot cavities

M Rakhmanov, M Evans and H Yamamoto

LIGO Project, California Institute of Technology, Pasadena, CA 91125, USA

Received 19 May 1998, in final form 12 November 1998, accepted for publication 2 December 1998

Abstract. We propose a method for *in situ* measurement of the length of kilometre-sized Fabry–Pérot cavities in laser gravitational wave detectors. The method is based on the vernier, which occurs naturally when the laser beam incident on the cavity has a sideband. By changing the length of the cavity over several wavelengths we obtain a set of carrier resonances alternating with sideband resonances. From the measurement of the separation between the carrier and a sideband resonance we determine the length of the cavity. We apply the technique to the measurement of the length of a Fabry–Pérot cavity in the Caltech 40m interferometer and discuss the accuracy of the technique.

Keywords: length measurement, vernier, Fabry–Pérot cavity, cavity length, Pound–Drever signal, LIGO

1. Introduction

Very long Fabry–Pérot cavities serve as measuring devices for interferometric gravitational wave detectors, which are currently being constructed [1–3]. Among them is the Laser Interferometer Gravitational Wave Observatory (LIGO) which will have 4 km long cavities [2]. The cavity length, defined as the coating-to-coating distance between its mirrors, is an important parameter for these gravitational wave detectors. It determines the detector's sensitivity and its overall performance. Therefore, the length must be known with high accuracy, especially if more than one wavelength of laser beam is required to resonate in the cavity. Since the length of LIGO Fabry–Pérot cavities can change by 0.4 mm due to ambient seismic motion of the ground we do not need to measure the length with accuracy better than 1 mm.

Measurement of distances of order a few kilometres with millimetre accuracy requires special techniques, such as GPS or optical interferometry. Application of the GPS technique would be difficult because the mirrors of the gravitational wave detectors are inside a vacuum envelope and the GPS receivers cannot be placed very close to the reflective surfaces of the mirrors. On the other hand, optical interferometry provides both convenient and precise measurements of distances [4]. The interferometric techniques which can be used for the cavity-length measurement are, for example, the method of a synthetic wavelength [4] and the method of frequency scanning [5]. These and other techniques with applications are discussed in [6]. Although these interferometric techniques may provide high-precision length measurements (to within 100 μm and better), they are

not well suited to Fabry–Pérot cavities of the gravitational wave detectors. All these techniques require installation of additional optics or modification to the optical configuration of the detectors.

In this paper we propose a technique for *in situ* measurement of the cavity length which requires no special equipment or modification to the interferometer. The technique is based on the ability of the Fabry–Pérot cavity to resolve close spectral lines. The only requirement is that there be at least two close wavelengths in the laser beam incident on the Fabry–Pérot cavity. This requirement will be easily satisfied by all gravitational wave detectors which are currently under construction, because optical sidebands are an essential part of their signal extraction schemes.

A laser resonates in a Fabry–Pérot cavity if the length of the cavity is equal to an integer number of the half wavelengths of the laser. Assume that one of the cavity mirrors is fixed and the other is moving along the cavity's optical axis. As the mirror moves, the cavity length changes and successive resonances appear in the cavity. These resonances correspond to the specific locations of the mirror, which form an array along the cavity's optical axis. The points of the array are equally spaced and separated by the half wavelength of the laser. Two slightly different wavelengths give rise to two arrays with slightly different spacings, thereby forming a vernier scale along the axis. This interferometric vernier can be used for the measurement of the cavity length in a way similar to a mechanical vernier.

Mechanical verniers have been used extensively in various precision measurement devices, such as callipers and micrometers. The idea of a vernier is that greater precision

is obtained if two slightly different length scales are used simultaneously [7, 8]. The technique we propose here is an extension of the vernier idea to the length scales set by the laser wavelengths.

Our method is similar to the method developed by Vaziri and Chen [9] for application to multimode optical fibres. They obtain the intermodal beat length of the two-mode optical fibres by measuring the separation between the resonances corresponding to these modes. We developed our method independently of them for application to the very long Fabry–Pérot cavities in gravitational wave detectors. Although it is different in motivation and underlying physics, our method resembles theirs, because of the common vernier idea.

2. The theory of the vernier method

A mechanical vernier is a combination of two length scales which usually differ by 10%. The optical vernier, described in this paper, is made out of two laser wavelengths which differ by roughly one part in 10^8 . To use the laser wavelengths in exactly the same way the mechanical verniers are used would be impossible. Instead we relate the optical vernier to the beat length, as we describe below.

Let the primary length scale be a and a secondary length scale be a' . Assume that $a' > a$ and consider two overlapping rulers made out of these length scales, which start at the same point. Let z be a coordinate along the rulers with its origin at the starting point. The coordinates for the two sets of marks are

$$z = Na \quad (1)$$

$$z' = N'a' \quad (2)$$

where N and N' are integers. Each mark on the secondary ruler is shifted with respect to the corresponding mark on the primary ruler. The shift accumulates as we move along the z -axis. At some locations along the z -axis the shift becomes so large that the mark on the secondary ruler passes the nearest mark on the primary ruler. The first passage occurs at $z = b$, where b is the beat length, defined according to the equation

$$\frac{1}{b} = \frac{1}{a} - \frac{1}{a'}. \quad (3)$$

Other passages occur at multiples of the beat length:

$$y = mb \quad (4)$$

where m is integer. Thus the number of beats within a given length, z' , is equal to the integer part of the fraction z'/b . The beat number, m , is related to the order numbers of the two nearest marks on the different rulers:

$$m = N - N'. \quad (5)$$

Let us define the shift of the mark at z' on the secondary ruler with respect to the nearest mark at z on the primary ruler as a fraction:

$$\mu = \frac{z' - z}{a}. \quad (6)$$

The shift is also equal to the fraction of the beat length

$$\mu = \frac{z' - y}{b}. \quad (7)$$

Cavity length measurement

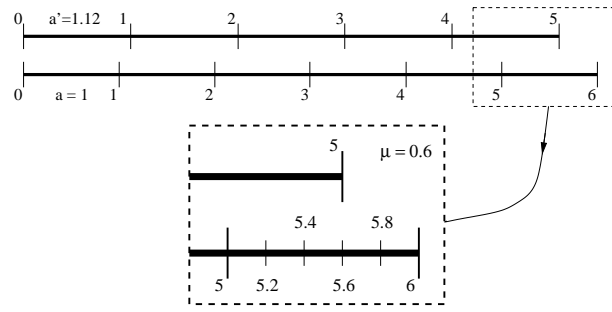

Figure 1. An example of a vernier. The integers are the order numbers N and N' . The length of the secondary ruler ($z' = 5a'$) is equal to 5.6.

A derivation of this equivalence is given in the appendix. This equivalence allows us to express the length of the secondary ruler in terms of the beat length:

$$z' = y + \mu b \quad (8)$$

$$= (m + \mu)b. \quad (9)$$

Therefore, if we know the beat number, m , and the fraction, μ , we can find the length, z' .

We illustrate the method on an example of a vernier with length scales $a = 1$ and $a' = 1.12$, as shown in figure 1. In this case the beat length is $9\frac{1}{3}$. There are no passages within the length shown in figure 1; therefore $m = 0$. From figure 1 we see that the shift is equal to 0.6. Thus we find that the length of the secondary ruler ($z' = \mu b$) is equal to 5.6, which is the correct result, as can be seen from the figure.

Consider a Fabry–Pérot cavity of length L . Let z be a coordinate along the optical axis of the cavity. Assume that the input mirror is placed at $z = 0$ and the end mirror is at $z = L$. A single-wavelength laser produces an array of resonances along the cavity's optical axis. Two slightly different wavelengths give rise to two overlapping arrays of resonances with slightly different spacings. In the experiment below the different wavelengths are obtained by phase modulation of a single-wavelength laser. Let the frequency of the phase modulation be f ; then the modulation wavelength is $\Lambda = c/f$, which is a synthetic wavelength for our measurement. The three most prominent components of the phase modulated laser are the carrier with wavelength λ_0 and the first-order sidebands with wavelengths $\lambda_{\pm 1}$, which are defined as

$$\frac{1}{\lambda_{\pm 1}} = \frac{1}{\lambda_0} \pm \frac{1}{\Lambda}. \quad (10)$$

Any two wavelengths can be used to obtain a vernier. For example, the primary scale can be set by the carrier, $a = \frac{1}{2}\lambda_0$, and the secondary scale can be set by either of the sidebands; $a' = \frac{1}{2}\lambda_{\pm 1}$. Then the coordinates for the carrier and the sideband resonances are given by the equations (1) and (2). Correspondingly, the beat length is set by the synthetic wavelength:

$$b = \Lambda/2. \quad (11)$$

Using equation (9), we can express the cavity length in terms of the synthetic wavelength:

$$L = (m + \mu) \frac{\Lambda}{2}. \quad (12)$$

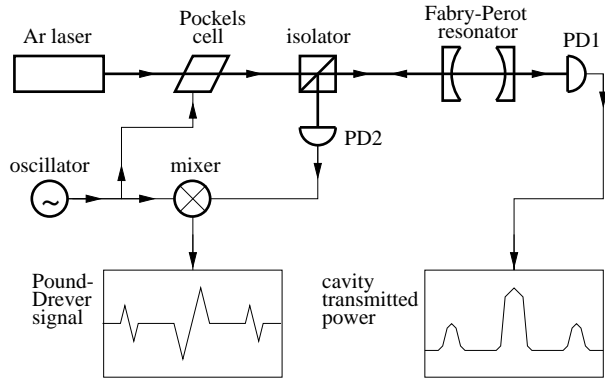

Figure 2. The set-up of the experiment. The cavity is inside the vacuum envelope which eliminates the fluctuations of the refractive index of air and acoustic coupling of the mirrors.

Here m is the number of exact beat lengths within the cavity length and μ is the excess fraction of the beat length. The beat number, m , can be found from the approximate length of the cavity

$$m \equiv \text{floor}\left(\frac{L}{\Lambda/2}\right) \quad (13)$$

where ‘floor’ stands for the nearest lower integer. The fraction, μ , can be obtained from the measurement of the shift between the carrier and the sideband resonances. As long as the approximate cavity length is known to within an accuracy better than the beat length, the beat number is defined exactly. Therefore, there is no error associated with the beat number.

3. Measurement results and discussion

We apply the technique to measure the length of the Fabry–Pérot cavity of the 40m prototype of the LIGO interferometer at Caltech. For our measurement we use one of the arm cavities of the interferometer and the Pound–Drever signal extraction scheme [10]. The set-up is shown in figure 2.

A single-wavelength ($\lambda_0 = 514.5$ nm) laser beam is generated by an Ar laser. The sidebands on the laser are produced by phase modulation at the Pockels cell, which takes its input from the RF oscillator with frequency $f = 32.7$ MHz. The synthetic wavelength corresponding to this frequency is $\Lambda = 9.167965$ m. The resulting multi-wavelength laser beam is incident on the Fabry–Pérot cavity. Both the input and the end mirror of the cavity are suspended from wires and are free to move along the optical axis of the cavity.

The approximate length of the cavity, known from previous measurements, $L = 38.5 \pm 0.2$ m, defines the beat number:

$$m = 8. \quad (14)$$

The fraction μ is obtained from the measurement of the sideband–carrier separation in the time-domain trace of the output signals. There are two output signals in the experiment; the cavity-transmitted power and the Pound–Drever signal. The signal proportional to the cavity-transmitted power is obtained from the photodiode PD1.

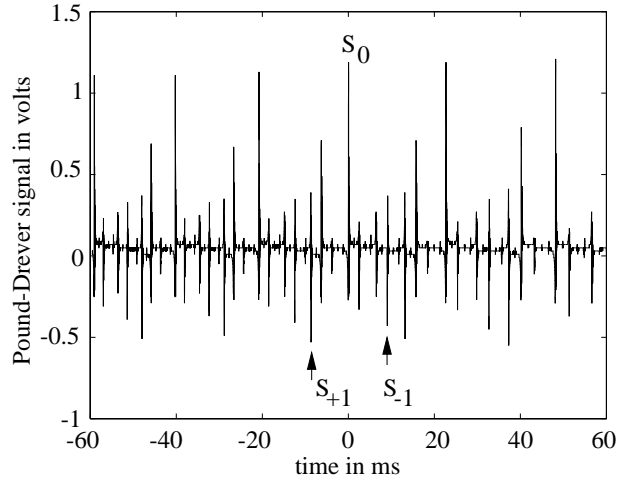

Figure 3. The oscilloscope trace of the Pound–Drever signal. The resonances corresponding to the carrier and the sidebands are marked by S_0 and $S_{\pm 1}$. Other resonances result from the higher order modes due to imperfections of the laser and tilts of the mirrors.

The Pound–Drever signal is the output of the photodiode PD2 rectified by the mixer. Either signal can be used for measurement of the fraction, μ . However, we choose the Pound–Drever signal because it provides higher precision than does the signal proportional to the transmitted power.

In the experiment the motion of the front mirror is damped by a control system and the end mirror is swinging freely through several wavelengths. As the end mirror moves through the resonances sharp peaks appear in the time-domain traces of the output signals. The traces are observed on the oscilloscope. The actual trace used for the analysis is shown in figure 3. From the trace we obtain the times when the mirror passes through the carrier resonances, $t_0(p)$, and the sideband resonances, $t_{\pm 1}(p)$, where p is an integer from 1 to 6. The times are found to within a precision of $1 \mu\text{s}$, set by the resolution of the oscilloscope. The carrier resonances are located at

$$z_0(p) = (p - 1)\frac{\lambda_0}{2} + u \quad (15)$$

where u is an unknown constant, which cancels out in the calculation. The location of the sideband resonances can be found from the times $t_{\pm 1}(p)$ if the trajectory of the mirror is known. We find the approximate trajectory of the mirror by polynomial interpolation between the carrier resonances. The plot of the interpolated mirror trajectory is shown in figure 4. Let the interpolation polynomial be $F(t)$. Using the polynomial, we find the locations of the sideband resonances as follows:

$$z_{-1}(p) = F(t_{-1}(p)) + u \quad (16)$$

$$z_{+1}(p) = F(t_{+1}(p)) + u. \quad (17)$$

Once the locations of the carrier and the sideband resonances are known, we can find the corresponding fractions as

$$\mu(p) = \frac{z_{-1}(p) - z_0(p)}{\lambda_0/2} \quad (18)$$

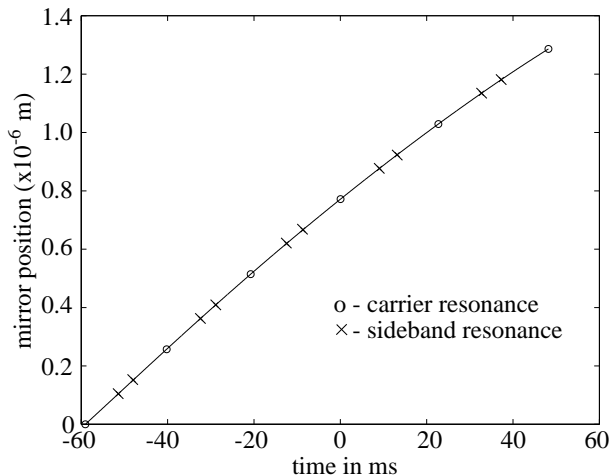

Figure 4. The interpolated mirror trajectory within the first six carrier resonances.

for the lower sideband and

$$\mu(p) = \frac{z_0(p) - z_{+1}(p)}{\lambda_0/2} \quad (19)$$

for the upper sideband. The results are shown in table 1. The average fraction and its standard deviation are

$$\mu = 0.4089 \pm 0.0008. \quad (20)$$

By substituting the beat number and the fraction into the equation (12) we obtain the length of the cavity:

$$L = 38\,546 \pm 4\text{mm}. \quad (21)$$

The error in the cavity length comes from the error in the beat length and the error in the fraction. In our experiment the dominant one was the error in the fraction, which is mostly the error of the polynomial interpolation. The interpolation error can be greatly reduced if the change in the cavity length is known with high precision. This can be done, for example, by controlling the cavity mirrors at low frequencies.

The limiting precision of the technique, δL , is determined by the signal used to obtain the fraction μ . For the transmitted power the limit comes from the finite width of resonances in the Fabry–Pérot cavity. The separation between the resonances in the transmitted power can be measured up to the width of a resonance. Therefore,

$$\delta L \simeq \frac{\Lambda/2}{\text{Finesse}} \quad (22)$$

which is roughly 4 mm for our experiment. This precision limit does not depend on the length of the cavity.

There is no limit due to the finite width if the resonances are observed in the Pound–Drever signal. In this case the separations between the resonances are found from zero crossings or peaks in the Pound–Drever signal and the shifts can be measured with a precision far better than the width of a resonance. For the Pound–Drever signal the limit on the precision is given by the uncertainty in the beat length

$$\frac{\delta L}{L} \simeq \frac{\delta \Lambda}{\Lambda} \quad (23)$$

Table 1. The fractions obtained from the interpolated mirror trajectory. The first and the last fringe contain only one sideband resonance.

Resonance order p	μ (−1 sideband)	μ (+1 sideband)
1	0.407 213	
2	0.409 232	0.410 154
3	0.408 725	0.408 647
4	0.408 816	0.409 038
5	0.409 685	0.409 093
6		0.408 188

which is defined by the stability of the oscillator. In our case 1 Hz stability of the oscillator sets the limit of 1 μm to the precision of the technique.

There are two small but noteworthy systematic errors in this method: one is due to the phase change upon reflection off the mirrors, the other is due to the Guoy phase of the Gauss–Hermite modes of the Fabry–Pérot cavity [11]. If the phase of the reflected laser is not exactly opposite to the phase of the incident laser at the mirror surface, the resonances in the cavity become shifted. This effect can be as large as $\lambda/4$ per mirror and is far below the precision of the technique. The Guoy phase also affects the location of the resonances and can be at most $\pi/2$ for the lowest mode of the cavity. Thus the largest contribution due to the Guoy phase is $\lambda/4$ and can also be neglected.

The measurement described in this paper is an example of the many possible realizations of the optical vernier. In our experiment the laser frequency was fixed but the cavity length was changing. One can take a different approach and sweep the laser frequency, keeping the cavity length fixed. In this approach the cavity length is locked to the carrier frequency of the laser and the two sidebands with fixed separation are swept across several free spectral ranges of the cavity. As the frequency of the two sidebands changes, successive resonances appear in the cavity. These resonances form a vernier, which can be analysed along the lines described in this paper. The advantage of this implementation is that there is no error due to the nonlinearity of the mirror motion. The interpolation may still be necessary in order to account for the nonlinearity of the sweep. However, we believe that the nonlinearity of the sweep and the error associated with it can be made much less than the interpolation error reported in this paper.

4. Conclusion

The optical vernier method is a simple and accurate way to measure the cavity length of a laser gravitational wave detector *in situ*. The method requires no special equipment or modification to the detector. We tested the method on the 40m prototype of the LIGO interferometers and attained a precision of 4 mm. The ultimate precision of the method is defined by the uncertainty in the beat length and is of the order of a few micrometres. The method is general and can be used for measuring the length of any Fabry–Pérot cavity for which one can perform a small adjustment of its length.

Acknowledgments

We are very grateful to G Hu for setting up the data acquisition for the experiment. We also thank S Whitcomb, A Lazzarini, J Camp and A Arodzero for discussions and their comments on the paper. This work is supported by the National Science Foundation of the USA under cooperative agreement PHY-9210038.

Appendix

The equivalence can be derived as follows. Consider the difference

$$z' - z = N'a' - Na \quad (24)$$

$$= N'(a' - a) - (N - N')a \quad (25)$$

$$= N'\frac{aa'}{b} - ma. \quad (26)$$

On dividing both sides of this equation by a we obtain the identity

$$\frac{z' - z}{a} = \frac{z' - y}{b} \quad (27)$$

which proves that the shift defined in equation (6) is equal to the fraction of the beat length defined in equation (7).

References

- [1] Bradaschia C *et al* 1990 Terrestrial gravitational noise on a gravitational wave antenna *Nucl. Instrum. A* **289** 518
- [2] Abramovici A *et al* 1992 LIGO: The Laser Interferometer Gravitational-wave Observatory *Science* **256** 325–33
- [3] Tsubono K 1995 300-m laser interferometer gravitational wave detector (TAMA 300) in Japan *Proc. 1st Eduardo Amaldi Conf. on Gravitational Wave Experiments, Frascati, June 1994* (World Scientific: Singapore) pp 112–14
- [4] Hariharan P 1992 *Basics of Interferometry* (Boston: Academic)
- [5] Zhu Y, Matsumoto H and O'ishi T 1991 Arm-length measurement of an interferometer using the optical-frequency-scanning technique *Appl. Opt.* **30** 3561–2
- [6] Bosch T and Lescure M (eds) 1995 *Selected Papers on Laser Distance Measurements* (Bellingham, WA: SPIE Optical Engineering Press)
- [7] Kent W 1950 *Mechanical Engineers' Handbook* (New York: Wiley)
- [8] Moffitt F H and Bouchard H 1975 *Surveying* (New York: Intext)
- [9] Vaziri M and Chen C L 1997 Intermodal beat length measurement with Fabry–Pérot optical fiber cavities *Appl. Opt.* **36** 3439–43
- [10] Drever R *et al* 1983 Laser phase and frequency stabilization using an optical resonator *Appl. Phys.* **31** 97–105
- [11] Siegman A E 1986 *Lasers* (Mill Valley, CA: University Science Books)