

# Laser power stabilization for second generation gravitational wave detectors

Frank Seifert, Patrick Kwee, Michèle Heurs, Benno Willke, Karsten Danzmann

*Max-Planck-Institut für Gravitationsphysik (Albert-Einstein-Institut) and Universität  
Hannover  
Callinstr. 38, 30167 Hannover, Germany*

We present results on the power stabilization of a Nd:YAG laser in the frequency band from 1 Hz to 100 kHz. High-power, low-noise photodetectors are used in a DC-coupled control loop to achieve relative power fluctuations down to  $5 \times 10^{-9} \text{ Hz}^{-1/2}$  at 10 Hz and  $3.5 \times 10^{-9} \text{ Hz}^{-1/2}$  up to several kHz, which is very close to the shot noise limit for 80 mA of detected photocurrent on each detector. We investigated and eliminated several noise sources like ground loops or beam pointing. The achieved stability level is very close to the requirements for the Advanced LIGO gravitational wave detector. © 2006 Optical Society of America

*OCIS codes:* 040.5160, 140.3570, 270.2500

Laser diode pumped solid-state laser systems are exquisitely suited for precision measurement, e.g. as the light source for laser interferometric gravitational wave detectors such as GEO600<sup>1</sup> or LIGO.<sup>2</sup> To achieve the sensitivity goals for the second generation of laser interferometric gravitational wave detectors such as Advanced LIGO,<sup>3</sup> care must be taken to eliminate noise sources which may limit the sensitivity, such as laser amplitude noise. Current plans for the Advanced LIGO detector call for the use of a 180 W laser system. Increased laser power will result in increased radiation pressure on the suspended mirrors, and fluctuations in the laser power will thus cause fluctuations in the mirror positions and result in additional noise in the gravitational wave signal channel. The most demanding laser amplitude noise requirement for Advanced LIGO is  $2 \times 10^{-9} \text{ Hz}^{-1/2}$  at 10 Hz.

Several previous laser power stabilization experiments<sup>4-7</sup> have produced residual noise levels of  $10^{-8} \text{ Hz}^{-1/2}$  or less for frequencies above 10 Hz up to several kHz. These papers showed that power stabilization is exceedingly difficult at low frequencies (below a few hundred Hz). All measurements are limited by an unknown source of excess noise. For higher frequencies the experiments are almost shot noise or loop gain limited. In this work we demonstrate the,

to our knowledge, best stability level achieved so far in the frequency range between 10 Hz and 10 kHz. We present a detailed analysis of the noise sources and set limits on fluctuations in auxiliary degrees of freedom and coupling constants.

The experimental layout used in this work is shown in figure 1. The laser was an Innolight Mephisto nonplanar ring oscillator (NPRO) with a total output power of 800 mW at 1064 nm and an internal noise eater to reduce the relative intensity noise at the relaxation oscillation frequency (at approx. 500 kHz). The laser was locked by the Pound-Drever-Hall technique to a small Fabry Perot ring cavity (FSR=714 MHz,  $\mathcal{F}$ =4100), the so called pre-modecleaner (PMC),<sup>8</sup> which acts as a spatial mode filter that reduces laser beam geometry fluctuations and beam pointing. This is important because the responsivity of the photodiodes varies across their surfaces<sup>9</sup> and variations in the beam position on the photodiodes lead to variations in the photocurrent. A multi-axes piezoelectric mirror placed at the output of the PMC can be used to investigate the coupling between beam pointing and apparent power fluctuations on the photodiodes.

At the output of the PMC the light is split into four beams of identical power which are aligned with similar optical pathlength onto photodetectors. A quadrant photodetector (QPD, Centronic QD50) is used to measure the pointing of the laser beam at the output of the PMC. For the intensity noise detection thermoelectrically cooled 2 mm InGaAs photodiodes from Hamamatsu<sup>10</sup> are used in a special transimpedance configuration ( $R_{TIA} = 100 \Omega$ ) which enables both low-noise and high-current operation. A reverse bias of 8 V was chosen to trade off the heat dissipation versus linear operating range. In this configuration the complete photodetector showed a constant slope efficiency up to 150 mW of optical power. For this experiment the light level incident on the photodetectors was approximately 110 mW with a measured quantum efficiency of  $\approx 86\%$  and was limited by the long-term cooling capability of the built-in thermoelectric cooler (TEC).

For power stabilization two identical photodetectors were used, one for the stabilization itself (in-loop, IL) and the other for an independent measurement (out-of-loop, OOL). The in-loop photodetector signal was compared to an ultra-stable second-order low-pass filtered voltage reference (AD587,<sup>11</sup> filter corner frequency 0.048 Hz) and was stabilized via feedback to an acoustic-optic modulator (AOM) at the input of the PMC. The control-loop is DC-coupled. An AOM was chosen to provide an actuator which is independent of the laser system used. Hence our setup can be used for many different lasers. Furthermore a coupling of the feedback signal into other laser parameters (e.g. frequency or pointing) can be avoided.

The control servo was designed with an upper unity gain point at around 100 kHz to achieve high gain at low frequencies. The pole of the cavity is at 86 kHz, which has to be taken into account in the design of the control-loop. The gain at frequencies below 100 Hz was at least 100 dB, which in the absence of additional noise sources should have been sufficient

to reduce the technical laser amplitude fluctuations to the shot noise level in the sensing photodetectors or to the noise level of the voltage reference used.

The complete detection (including the optical resonator) is placed in a vacuum tank to minimize the influence of air-currents. All experiments were performed at low vacuum (pressure  $<1$  mbar).

The performance of the system is shown in figure 2. The detection noise is dominated by the combined dark noise of the photodetectors and the FFT analyzer (Stanford Research SRT785 with home made battery powered preamplifier). The dark noise is comfortably far below the measured out-of-loop intensity noise level. The shot noise for each photodetector ( $i_{ph}=80$  mA) is  $2 \times 10^{-9} \text{ Hz}^{-1/2}$ . For low frequencies the in-loop measurement is limited by the noise level of the voltage reference (comparable to the detection noise level) and for frequencies higher than 3 kHz by the loop gain.

The out-of-loop measurement is fundamentally limited by the uncorrelated sum of the shot noise on the in-loop and out-of-loop detector. Summing the shot noise from both photodetectors in quadrature gives a minimum out-of-loop measurement noise of  $2.8 \times 10^{-9} \text{ Hz}^{-1/2}$ . In addition the noise of the voltage reference used to set the operation point of the control loop is imprinted on the light. The out-of-loop measurement of  $3.5 \times 10^{-9} \text{ Hz}^{-1/2}$  for  $\approx 100$  Hz up to a few kHz indicates that an additional technical noise source of the same size as the shot noise contaminates either the in-loop measurement and is imprinted on the light by the control loop or leads to excess noise in the out-of-loop measurement. Most probably a combination of both effects describes the measurement best. For Fourier frequencies below 100 Hz the residual out-of loop noise was higher. At the lowest frequency of concern for ground-based gravitational wave detectors like Advanced LIGO (10 Hz) the noise increased to  $5 \times 10^{-9} \text{ Hz}^{-1/2}$ .

Various electronic noise sources were characterized, and it could be observed that the residual noise level at low frequencies is highly sensitive to small leakage currents caused by ground loops. Even weak ground loops (e.g. due to capacitive coupling) lead to higher noise levels, but even when using differential inputs one has to heed floating potentials due to finite common-mode rejection of the input stages. Finally single-ended signal transmission was chosen and all electronic sub-assemblies were powered independently. Cables between sub-assemblies have been shortened to a minimum to reduce electromagnetic coupling into the system. After careful optimization of electronics and cabling a rising noise level at lower frequencies was still observable. Slew rate limits of the amplification stages due to electromagnetic interference were ruled out.

Polarization jitter of the incoming laser beam in combination with polarization dependent beam splitting could cause differential intensity variations at the in-loop and out-of-loop photodetectors. Further purification of the polarization of the incoming laser beam by means

of high extinction polarizing beam splitters at the input of the PMC did not lead to higher stability.

Frequency noise could be converted to intensity noise, e.g. due to wavelength dependent response of the photodiodes or the splitting ratio of the power beamsplitters. A noise estimation with the free running frequency noise of the NPRO showed that the contribution is much smaller and different locking arrangements showed no improvement.

To quantify the effect of beam pointing the spatial uniformity of the implemented photodiodes were measured in an additional experiment with a spatial resolution of  $10\ \mu\text{m}$  and gave a relative sensitivity gradient as large as  $2.2 \times 10^{-5}/\mu\text{m}$ .<sup>12</sup> In combination with a measurement of the beam pointing at the output of the PMC a projection of the pointing noise coupling into RIN measurement showed a negligible influence at the current intensity noise level. Please note that the beam center had to be aligned to the position on the photodiode with the smallest efficiency gradient to an accuracy of  $300\ \mu\text{m}$ .

Uncorrelated temperature fluctuations of both photodiodes could cause power fluctuations. A typical value for the responsivity temperature coefficient for InGaAs-Photodiodes is  $0.039\%/K$ .<sup>9</sup> Therefore a temperature stability of  $\approx 5\ \mu\text{K}$  is necessary to not be limited by temperature fluctuations. Since the photodiodes with built-in TEC used in our experiment contained only one temperature sensor, an out-of-loop measurement of the temperature stability was not possible. However switching from temperatur controlled operation of the photodiode to constant current operation of the TEC yield the same out-of-loop performance of the power stabilization.

Low frequency noise in the photodiodes itself might become relevant at low frequencies and is in our opinion the prime candidate to explain the excess noise below 100 Hz. Several groups have shown that the noise spectrum of the dark current and photocurrent depends on several semiconductor parameters and also on operating parameters such as reverse bias voltage, wavelength of the incident light and illumination level.<sup>13-16</sup> First experiments with a set of two large area InGaAs photodiodes in a balanced detection scheme showed a comparable behavior to investigations<sup>17</sup> on  $75\ \mu\text{m}$  InGaAs photodiodes under different bias and illumination conditions. For frequencies above a few hundred Hz our experiments showed shot noise limited performance and for lower frequencies the noise level increased proportionally to the detected optical power. This could explain the out-of-loop performance because the detection noise level of the photodetector is measured without light and is therefore not the actual detection limit with a certain amount of optical power on the photodiode.

In conclusion we have achieved a power stabilization of a Nd:YAG laser of  $5 \times 10^{-9}\ \text{Hz}^{-1/2}$  at 10 Hz, which is very close to the requirements for the Advanced LIGO gravitational wave detector. As already noticed in Rollins et al.<sup>4</sup> electronic grounding noise was discovered to be a critical issue. Nevertheless at this time it is not known what the limiting factor of the

out-of-loop performance is, especially at low frequencies. Further work is required to identify the limiting noise source at low frequencies. A detailed analysis of low frequency noise in different commercial available large area InGaAs photodiodes is currently under investigation. This research is supported by the DFG Sonderforschungsbereich 407 "Quantum-Limited Measurement Processes with Atoms, Molecules and Photons"

## References

1. S. Hild, H. Grote, J.R. Smith and M. Hewitson for the GEO600-team, "Towards gravitational wave astronomy: Commissioning and characterization of GEO600", J. Phys.: Conf. Ser. **32**, 66-73 (2006)
2. D. Sigg, "Commissioning of LIGO detectors", Class. Quant. Grav. **21**, S409-S415 (2004)
3. J. Giaime, submitted to Class. Quant. Grav. special issue for Amaldi 6 (2006)
4. J. Rollins, D. Ottaway, M. Zucker, R. Weiss, and R. Abbott, "Solid-state laser intensity stabilization at the  $10^{-8}$  level", Opt. Lett. **29**, 1876-1878 (2004)
5. B.W. Barr, K.A. Strain, C.J. Killow, "Laser amplitude stabilization for advanced interferometric gravitational wave detectors", Class. Quant. Grav. **22**, 4279 (2005)
6. R. Abbott, P. King, "Diode-pumped Nd:Yag laser intensity noise suppression using a current shunt", Rev. Sci. Instrum. **72**, 1346 (2000)
7. F. Nocera, "LIGO laser intensity noise suppression", Class. Quant. Grav. **21**, S481-S485 (2004)
8. B. Willke, N. Uehara, E. Gustafson, R. Byer, P. King, S. Seel, and R. Savage, Jr., "Spatial and temporal filtering of a 10-W NdYAG laser with a FabryPerot ring-cavity premode cleaner", Opt. Lett. **23**, 1704-1706 (1998)
9. PerkinElmer Optoelectronics, "Large-Area InGaAs Photodiodes", www.perkinelmer.com, Datasheet (2000)
10. Hamamatsu Photonics K.K., "InGaAs PIN photodiode G8605 series", www.hamamatsu.com, Datasheet (2001)
11. Analog Devices, "High Precision 10 V Reference", www.analog.com, Datasheet (2005)
12. P. Kwee, "Charakterisierung von Lasersystemen für Gravitationswellendetektoren", Diploma thesis, University of Hannover, Germany (2005)
13. A.M. Joshi, G.H. Olsen, V.S. Ban, E. Mykiety, M.J. Lange, D.T. Mohr, "Reduction of  $1/f$  noise in multiplexed linear  $\text{In}_{0.53}\text{Ga}_{0.47}\text{As}$  detector arrays via epitaxial doping", IEEE T Electron Dev. **40** (2), 303-308 (1993)
14. M. Rimini-Döring, A. Hangleiter, S. Winkler, N. Klötzer, "Non-Equilibrium Generation-Recombination Noise in InGaAs/InP Photodiodes", Appl. Phys A **54** (2), 120-123 (1992)
15. J. Kimmerle, W. Kuebart, E. Kuehn, O. Hildebrand, K. Loesch, G. Seitz, "Low Frequency Noise In InGaAs/InP-Photodiodes" in *Noise in Physical Systems and 1/f Noise*,

- M. Savelli, G. Lecoy and J-P. Nougier, eds. (Elsevier Science Publ. B.V., 1983) pp. 249-252
16. T.G.M. Kleinpenning, "1/f noise in p-n junction diodes", *J. Vac. Sci. Technol. A* **3**, 176 (1985)
  17. L. He, Y. Lin, A.D. van Rheeën, A. van der Ziel, A. Young, J.P. van der Ziel, "Low-frequency noise in small InGaAs/InP p-i-n diodes under different bias and illumination conditions", *J. Appl. Phys.* **68** (10), 5200 (1990)

## List of Figures

Fig. 1 Experimental setup: The laser (NPRO) is locked to a ring cavity (PMC). The control signal for the power stabilization comes from the in-loop detector (IL-PD), and the out-of-loop detector (OOL-PD) is used as an independent sensor. An acousto-optical modulator (AOM) is used as the power actuator. A quadrant photodiode (QPD) is used to measure pointing of the laser beam at the output of the PMC. (EOM : electro-optical modulator, FI : faraday isolator, PZT : piezoelectric mirror)

Fig. 2 Performance of the power stabilization loop: Relative intensity noise (RIN) as measured by in-loop and out-of-loop photodetectors. The measurements were taken with 80 mA of photocurrent. Also shown: free running laser noise, detection noise (photodetector dark noise, amplifier and analyzer noise) and the calculated shot noise limit for this measurement.

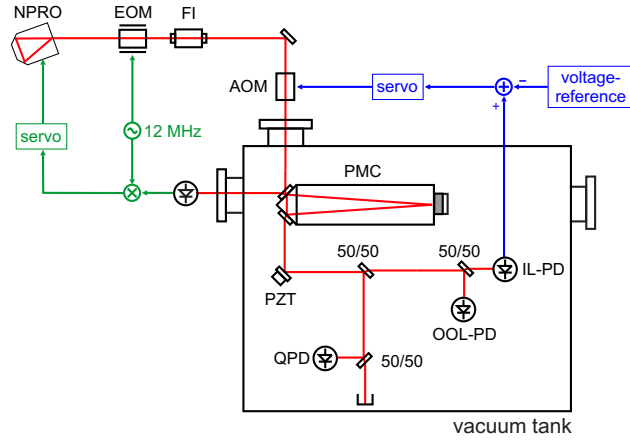

Fig. 1. Experimental setup: The laser (NPRO) is locked to a ring cavity (PMC). The control signal for the power stabilization comes from the in-loop detector (IL-PD), and the out-of-loop detector (OOL-PD) is used as an independent sensor. An acousto-optical modulator (AOM) is used as the power actuator. A quadrant photodiode (QPD) is used to measure pointing of the laser beam at the output of the PMC. (EOM : electro-optical modulator, FI : faraday isolator, PZT : piezoelectric mirror)

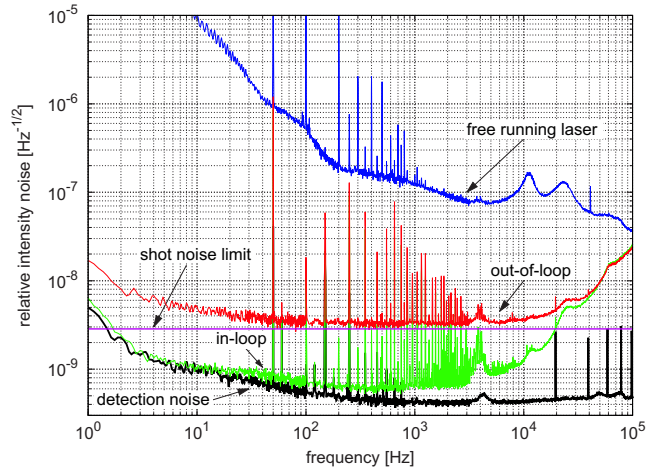

Fig. 2. Performance of the power stabilization loop: Relative intensity noise (RIN) as measured by in-loop and out-of-loop photodetectors. The measurements were taken with 80 mA of photocurrent. Also shown: free running laser noise, detection noise (photodetector dark noise, amplifier and analyzer noise) and the calculated shot noise limit for this measurement.