

Scope of ALUK work packages			
Area	Item (WP) Included	Item Inclusion to be defined	Item Excluded
A Suspension types	A1 (3) See figure 2 for which SUS are included (these are “the BSC SUS”). One ETM is a first article. A2 (3) Six spare SUS	Decision on whether the CP is part of the ITM to be taken March 2004 – current baseline (RODA) is that CP will be part of ITM.	
B Suspension structures	B1 (3) Structures B2 (3) All blades and clamps B3 (3) Suspension wires B4 (3) mass catcher and earthquake stops B5 (3) All metal masses (see figure 1) B6 (3) Baffle fixings – for main optics baffles B7 (3) Baffles to protect fibres from beam B8 (3) Fittings for CP heating B9 (3) Adjustable fittings for OSEMS and EC dampers (extent of adjustability TBD by RJSG and JR) <u>B10 (3) All parts to be cleaned, first articles to be UHV clean and baked</u>		BE1 Baffles for main optics BE2 CP heaters
C Optics	C1 (2) All non-metal masses except some TMs, see figure 1 <u>and addendum 4.</u> C2 (5) Four test mass blanks C3 (2) Ears for all BSC optics including spares C4 (2) “H” pieces if ribbons are used.		CE1 Test mass for two IFOs, any spare test masses CE2 Polishing of test masses CE3 Folding mirror, compensator plate, beam splitter

	Included	TBD	Excluded
D OSEMs for BSC noise prototypes	D1 (4) OSEM head, wired, with emitter/detector pair D2 (4, icw 3) Magnet and flag assembly D3 (4) Pigtail fixed to OSEM and with fitted plug D4 (4) Fixing bracket for OSEM D5 (4) "system spares" D6 (4, may be 3) EC dampers	DU1 Number of in-process spares required – for Bham and RAL to decide	
E OSEMs for production BSC SUS	See figure 2 for which are the BSC SUS E1 TO E5 (3) As above E6 (3) EC dampers E7 (3) System spares		EE1 OSEMs for non-BSC SUS (LIGO labs may later decide to procure these as part of UK order)
F Drive electronics For noise prototypes and production SUS, BSC and HAM	F1 (4) Minimum spec for wiring between pigtail and satellite box F2 (4) Drive electronics taking analogue signals F3 (4) Amplification of sensor signals giving analogue outputs F4 (4) Hardware of satellite boxes using supplied DC power supply F5 (4) Final regulation of provided DC power F6 (4) Wiring "pigtails" that go from the OSEM to a bulkhead fitting on the SEI, near the SUS. F7 (4) System spares		FE1 Bulkhead connector on SEI table. FE2 Wiring from SEI bulkhead fitting near the SUS, to the satellite box or equivalent outside but local to the tanks. FE3 Power supplies converting mains to DC power supply FE4 Any electronics other than as noted under F2 and F3
G ES drives for ETMs	G1 (2) design for ES drive electrode pattern G2 (2) feasible method to fix wires to reaction test mass electrodes G3 (3) System to bring wires from reaction test masses to SEI bulkhead fittings G4 (3) application of ES drive electrode pattern ("gold plating") G5 (4) Drive electronics for ES drive G6 (4) Drive electronics taking analogue signals G7 (4) Wiring "pigtails" that go from the reaction mass to a bulkhead fitting on the SEI, near the SUS. G8 (4) System spares	GU1 (should the coatings be in WP3, 4 or 5?) ¹ <u>GU2 should the UK be putting coatings on masses procured by others?</u>	GE 1,2,3,4 As above

¹ The reaction masses are in WP5, the design of the coating is in WP2 and the coating is in WP3.

	Included	TBD	Excluded
H Assembly procedures and equipment	<p>H1 (3) Procedure and equipment to safely assemble all masses into SUS structure</p> <p>H2 (2) “research” procedure to assemble TM/fibre/PM (aka “catcher”)</p> <p>H3 (3) “production” procedure and equipment to assemble TM/fibre/PM</p> <p>H4 (3) Procedure and equipment to safely assemble ready-made monolithic TM/fibre/PM assembly into SUS</p> <p>H5 (3) Procedure and equipment to make the assembly secure for movement to vac tank, and thereafter to bring the assembly into its usable state</p> <p>H6 (3) Procedure and equipment to allow alignment (details unclear)</p> <p>H7 (3) Procedure and equipment to replace broken fibre and broken wire</p> <p>H8 (3) Draft assembly procedures and “mark one” assembly tooling at LASTI for noise prototypes</p> <p>H9 (3) Assembly, with local staff, of noise prototypes at LASTI. Iterate on tooling. Some commissioning work, extent TBD</p> <p>H10 (3) Assembly, with local staff, of two SUS at each site (LLO, LHO)</p> <p>H11 (3) Assistance and advice with assembly work by others</p> <p>H12 (3) fixing positions for alignment targets.</p> <p>H13 (5 and 3) Procedures and equipment to bond ears and H pieces</p> <p><u>H14 Assembly tooling to be UHV cleaned and baked.</u></p>		<p>HE1 Procedures, Lifting beams etc to install assembly into vac tank. Note that some assembly equipment may be used during installation. Such equipment is included in the scope of the UK work.</p> <p>HE2 Measuring equipment for alignment</p> <p>HE3 Assembly of SUS beyond the first two at each site</p> <p>HE4 Any assembly work beyond the scope of the procedures and equipment we are supplying</p> <p>HE5 Procedure and equipment to make the ribbons/fibres on site</p> <p>HE6 Targets to be used during installation and alignment</p>
J Design documents	<p>J1 (3,4,5) Interchange, as required, of 3D models</p> <p>J2 (3,4) Full drawings in electronic form (dxf or pdf) as used for manufacture</p> <p>J3 (3,4,5) Design review documentation – drawings and descriptive text plus presentations</p> <p>J4 (3,4,5) Participation in design reviews.</p>		

Unless otherwise noted, procedures include devising and writing a procedure subject to review. Hardware items include design subject to review, procurement, payment, and delivery. (By procurement I mean organise required tender action or otherwise locate a supplier, visit suppliers to verify competence, place tender, liaise with supplier during manufacture, inspect goods on receipt and correct any problems).

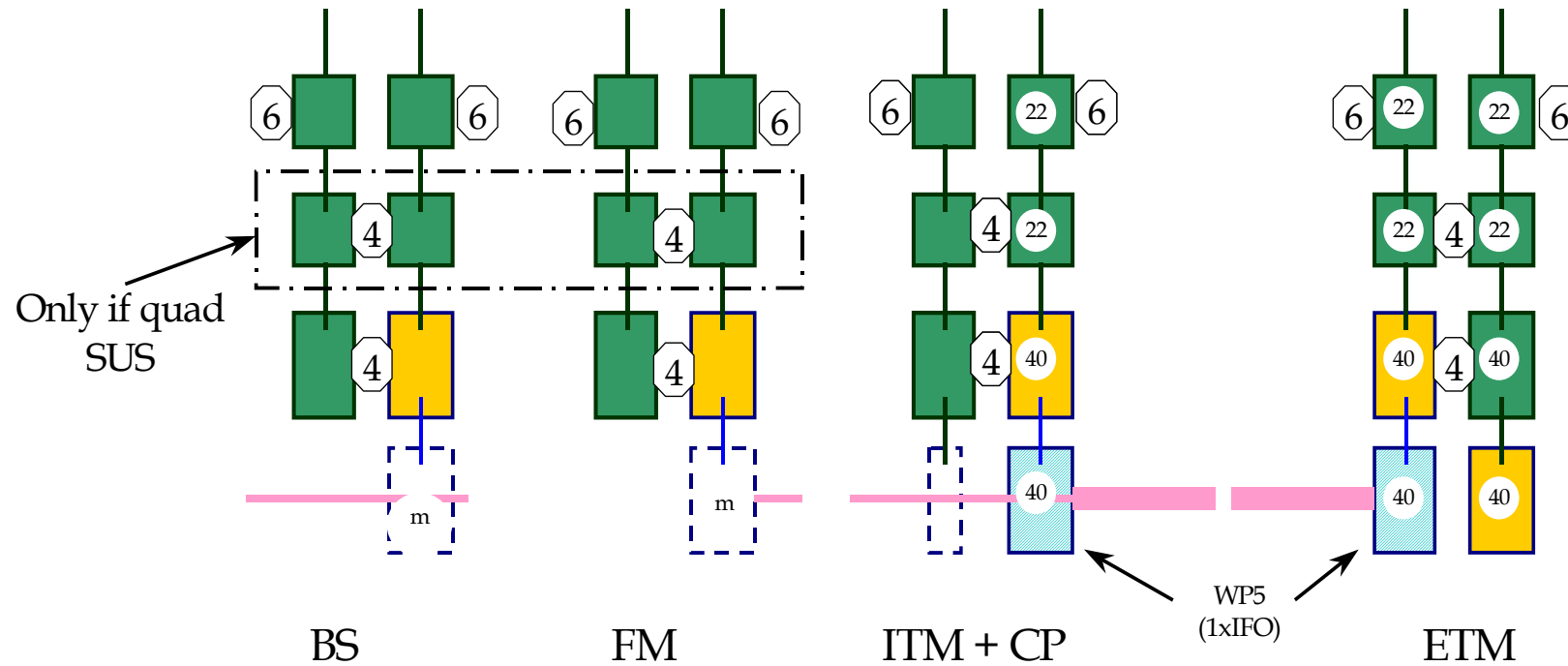

Key

- = non-metal, WP2
- = metal, WP3
- = not UK
- = WP2, 1 IFO only

Figure 1. Masses included in ALUK scope

Also includes current OSEM counts and masses for information only - not part of specification. BS/FM masses will be identical see RODA.

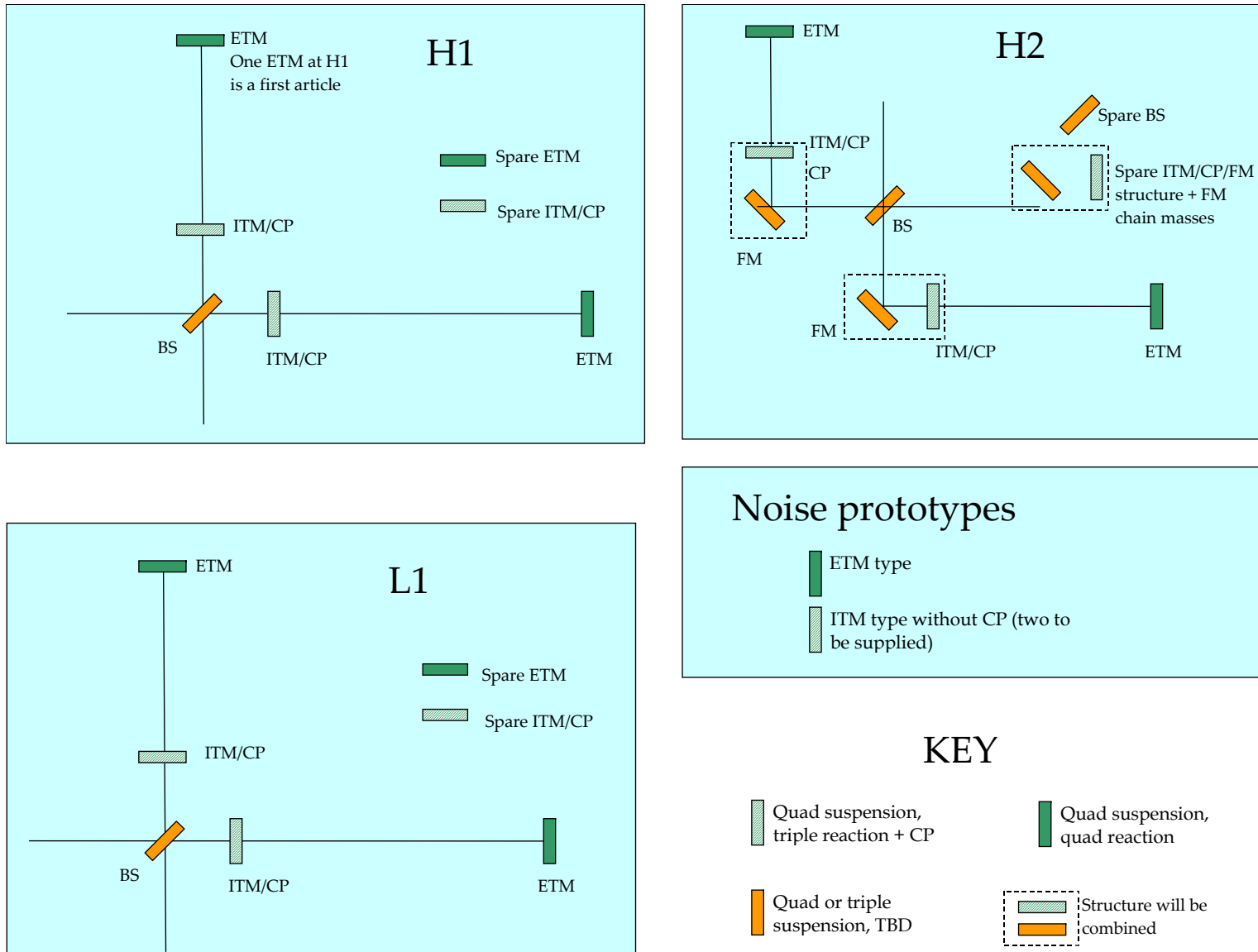

Figure 2 – SUS types in ALUK

Revision history

A – made during the Hannover LSC meeting

B – ditto after discussions with Dennis and Jim

C – after feedback from Norna, and others, and adding issues list from Glasgow August 2003 meeting.

D – feedback from David Shoemaker – see email sent 090903 at 12:03.

E - added scope item numbers

00 – First release on DCC after telecon of 30 Sept 2003 – see email of 1 oct 03

01 – added third noise prototype 13 nov 2003

02 – removed third noise prototype, included OSEMS for HAM noise prototypes ($14*(4+1+1) +6$) plus 10% extra Minor changes in wording of main table row A, (RODA now makes CP/IM commonality the baseline). Some WP5 items should be WP2. FM and BS have no test reaction mass in final table. January 2004.

03 – May 2004: Clarified cleaning requirements (B10, H14). Modified count table to split out OSEMs and electronics in a clearer form. Removed possible separate CP suspension (M040005 and T040085 refer). BS and FM now likely to be triples (See T040027). July 2004: Added addendum 2 with table of penultimate and reaction masses (from CAC). EC dampers for noise prototypes (item D6) now part of WP3. Added query GU2 on gold plating masses.

Table 1. Count of structures and masses etc										
	BSC								System spares	Total
	ITM + CP	ITM+CP+FM			ETM	Noise prot		BS		
		ITM+CP chain	FM chain	structure		ITM	ETM			
Count (L1)	2				2			1		
Count (H1)	2				2			1		
Count (H2)		2	2	2	2			1		
Count (spare)	2		1	1	2			1		
Count (NP)						1	1			
Total	6	2	3	3	8	1	1	4		
	<i>numbers per SUS</i>									
Structure	1	1	0	1	1	1	1	1		25
TOP mass	1	1	1		1	1	1	1		25
UI Mass	1	1	0		1	1	1	0		18
PU mass	1	1	1		1	1	1	1		25
Test mass	<i>4 blanks total</i>									4
TOP R mass	1	1	1		1	1	1	1		25
UI R Mass	1	1	0		1	1	1	0		18
PU R mass	1	1	1		1	1	1	1		25
Test R mass					1	1	1			10
Metal masses	5	5	5		5	5	5	3		117
non-metal masses	1	1	1		2	2	2	1		35
Ears	8	8	8		8	8	8	8	50	250
Mass set (*)	A	A	B		A	A	A	B		

black, WP3, RAL

pink WP2 or 5, Glasgow

(*) The "Mass set" is the combination of masses in the chain (eg 22-22-40-40)

Table 2. Count of OSEMs.																
<i>OSEMs which are to be provided by LIGO labs are included for reference only.</i>																
	BSC					HAM						Total				
	ITM + CP	FM	ETM	Noise prot		BS	RM	IMC	OMC	RM NP	MC NP	Aux	Bham	LIGO	RAL	Overall
				ITM	ETM											
Count (total)	8	3	8	1	1	4	9	12	6	1	5	1				
	Per SUS															
Hybrid-type OSEMs	20	16	20	20	20	16	14	14	10	14	14	5				
Eddy-current dampin	2	2	2	2	2	2	2	2	2	2	2	0				
	Total numbers															
Hybrid-type OSEMs	160	48	160	20	20	64	126	168	60	14	70	5				
Eddy-current dampin	16	6	16	2	2	8	18	24	12	2	10	0				
	Total numbers with system spares															
Spares level (OSEMs)	20%	20%	20%	20%	20%	20%	20%	20%	20%	20%	20%	20%				
Spare level (ECD)	10%	10%	10%	10%	10%	10%	10%	10%	10%	10%	10%	10%				
Hybrid-type OSEMs	192	58	192	24	24	77	152	202	72	17	84	6	155	426	519	1100
Eddy-current dampin	18	7	18	3	3	9	20	27	14	3	11	0	0	75	58	133

Key Black RAL
 Blue Birmingham
 Red LIGO Labs

Table 3. Electronics channels		
	OSEMs (from table 2)	Electrostatic 4 per ETM
Without system spares	915	12
Spares level	20%	4 Per site
With system spares	1098	20

Updated Scope Penultimate & Reaction Masses

LIGO.4.03.4.2.1. Penultimate Blanks		
New Name	Description	Quantity
SUS Penultimate Blanks - FA (First Article)		
ETM penultimate mass	ETM-BSC_IM - 317mm dia. X 133 mm thick Glass	1
ETM reaction mass	ETM - BSC Heavy Glass	1
ETM reaction mass SPARE	ETM - BSC Heavy Glass SPARE	1
ETM penultimate mass SPARE	ETM - BSC_IM 317mm dia.x133 mm thk Glss-SPARE	1
	SUB-TOTAL	4
SUS Penultimate Blanks - IFO1		
BS penultimate mass	BS-BSC_IM - 353mm dia. X 63 mm thick mat	1
ITM penultimate mass	ITM - BSC Heavy Glass	2
ETM penultimate mass	ETM - BSC_IM - 317 mm dia. X 133 mm thick	1
BS penultimate mass SPARE	BS-BSC_IM - 353 mm dia. X 63 mm SPARE	1
ETM reaction mass	ETM- BSC Heavy Glass	1
	SUB-TOTAL	6
SUS Penultimate Blanks - IFO2		
BS penultimate mass	BS-BSC_IM - 353mm dia. X 63 mm thick mat	1
BS penultimate mass SPARE	BS-BSC_IM - 353 mm dia. X 63 mm SPARE	1
ETM penultimate mass SPARE	ETM - BSC_IM - 317 mm dia. X 133 mm thick SPARE	1
ETM reaction mass SPARE	ETM- BSC Heavy Glass SPARE	1
ITM penultimate mass	ITM - BSC Heavy Glass	2
ETM reaction mass	ETM - BSC Heavy Glass	2
ETM penultimate mass	ETM-BSC_IM-317mm dia. X 103 mm thick	2
	SUB-TOTAL	10
SUS Penultimate Blanks - IFO3		
ETM reaction mass	ETM - BSC Heavy Glass	2
BS penultimate mass	BS-BSC_IM - 353mm dia. X 63 mm thick mat	1
ITM penultimate mass	ITM - BSC Heavy Glass	2
ETM penultimate mass	ETM-BSC_IM-317mm dia. X 103 mm thick	2
ETM penultimate mass SPARE	ETM - BSC_IM - 317 mm dia. X 133 mm thick SPARE	1
BS penultimate mass SPARE	BS-BSC_IM - 353 mm dia. X 63 mm SPARE	1
FM penultimate mass	FM-BSC_IM- 353mm dia.x 121mm thick mat	2
ETM reaction mass SPARE	ETM- BSC Heavy Glass SPARE	1
	SUB-TOTAL	12
	TOTAL	32
Noise Prototypes - from RAL's 4.03.3.3.5.5.		
ETM reaction mass	ETM - BSC Heavy Glass	1
ETM penultimate mass	ETM - BSC_IM-317mm dia. X 103 mm thick	1
ITM penultimate mass	ITM - BSC Heavy Glass	1
dummy CP	ETM - BSC Heavy Glass	1
ETM reaction mass - SPARE	ETM - BSC Heavy Glass	2
ETM penultimate mass - SPARE	ETM - BSC_IM-317mm dia. X 103 mm thick	2
ETM reaction mass - (Glasgow)	ETM - BSC Heavy Glass	2
ETM penultimate mass - (Glasgow)	ETM - BSC Heavy Glass	2
	SUB-TOTAL	12
	GRAND TOTAL	44

compared with proposal estimate of 64

compared with proposal estimate of 64

NOTES:

- (1) FA = First Articles and these with end up at IFO1
- (2) Noise prototype masses are currently costed under 4.03.3.3.5.5. In proposal. This scope and associated costs require to be transferred to Glasgow.
- (3) ETM pen and reaction masses are the same except for the wedge. Same blanks, different wedge, different polish.
- (4) ETM and ITM pens are the same.
- (5) BS and FM pens are the same.
- (6) Spares policy for suspensions as of 29 June 2004 (Janeen, Gari, Justin, Caroline). For each IFO there are a total of three spares as follows:
 1 ETM/ITM penultimate
 1 ETM reaction (has electrostatic & photon drive coatings + is wedged)
 1 BS/FM penultimate
- (7) Added in required penultimate and reaction masses for noise prototypes of WBS LIGO 4.03.3.3.5.5. Based on two ETM noise prototypes.

SUMMARY

Each IFO has: ETM pen x 2 ETM react x 2 ITM pen x 2 BS pen x 1 One IFO has additional: FM pen x 2 Each IFO has spares ETM pen x 1 ETM react x 1 BS/FM pen x 1 TOTAL = 32	Add the two noise prototypes plus spares and masses for Glasgow ETM pen x 1 ETM react x 1 ITM pen x 1 dummy CP x 1 ETM react (SPARE) x 2 ETM pen (SPARE) x 2 ETM react (Glasgow) x 2 ETM pen (Glasgow) x 2 TOTAL = 12
--	---

GRAND TOTAL
44