

# LIGO@MIT:

---

## Transition to Operations and Advanced Detector R&D

M. Zucker

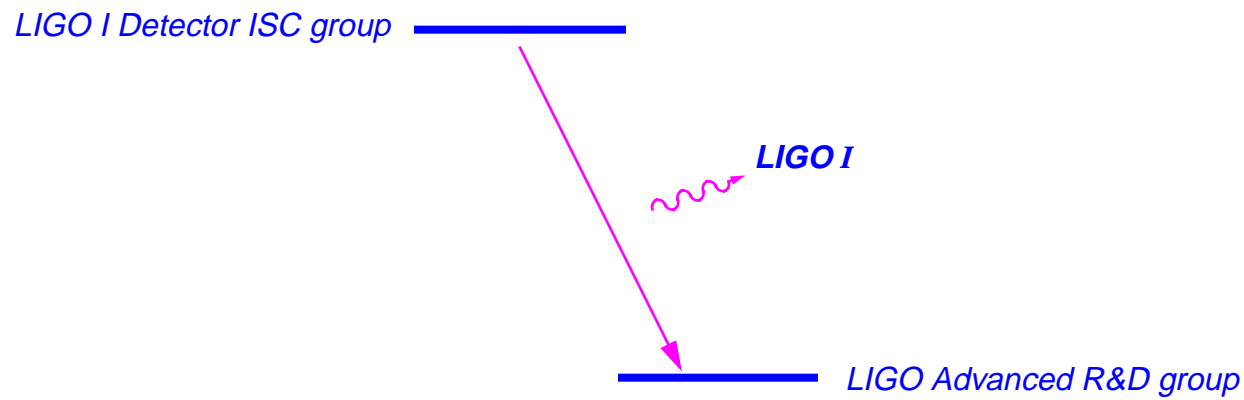

# NOW: Construction

---

# Next: Integration & Commissioning

---

- Priority: *get LIGO I into operation*
- Focus is site-based
  - Installation, commissioning, diagnostics centered at Hanford & Livingston
  - “Pre-lockup” phase: all hands on one task (lead, follow or get out of the way)
  - “Post-lockup” phase: break out parallel investigations & concurrent tasks
- Campus facilities deployed mainly in support roles
  - Field equipment prep, cal, test (even repairs...)
  - Diagnostic modeling/simulation
  - “Integration Support R&D” ; rapid response to new findings
    - > First machine of its kind; expect issues needing experimental answers
    - > e.g., optical scattering, outgassing, PEM correlations, detector nonlinearity, surface analysis, vibration/acoustic modes, RFI tests, ... ?

# Remote Site/Campus Staffing Model

---

- Challenge:
  - involve students, postdocs, faculty in work which is fundamentally site-based
  - maintain ties & communication between site & campus resident personnel
  - help sites draw on campus resources, experience
- Response: staff rotations
  - cut deals for extended leaves (~2 weeks to ~academic term or longer)
  - terms interleaved so team members overlap, continuity preserved
  - projects given both site- and campus-based (or portable) components
- 2 postdocs, 1 student signed up with Weiss so far (PEM, quicklook data analysis, diagnostics)
- Others looking at installation schedule for best phasing

# End State: Operations & Advanced R&D (as we'd like to see it)

---

- Data analysis...physics...discovery!
- LIGO Operations Support
  - Site staff rotations continue to support facility operations
  - Campus analytical, simulation, experimental detector support continues
  - Update/revisions/service for LIGO I systems & instrumentation
- Advanced Subsystem and Detector Development
  - Double Pendulum Suspension
  - Active Seismic Isolation
  - High-power Lasers & Optics
  - Advanced Detector Configurations

# Detector Upgrades: Advanced Subsystem & Configuration Staging

---

- Trial/debug of new technology in LIGO directly impacts observation time (‘either upgrade, or do science’)
- Need primary testing coverage *offline*; hierarchical development/engineering path
  - Modeling, analysis, simulation
  - Tabletop proof of concept/technology demonstration
  - “Large”-scale test on suspended, evacuated interferometer testbeds
- Multiple suspended, evacuated testbeds required for scaling confidence & total throughput capacity
- Problem: “laboratory scale” final test **isn’t so final!**
  - Too many parameters are tied up intricately with mechanical dimensions

# Problems with “scaled-down” test extrapolation:

---

- Fit, interference, & assembly not fully addressed (though mockups help)
- Design extrapolation subject to errors (pole frequencies, reaction inertias, mechanical impedances)
- Parasitic structural resonances may go undetected
- Dynamic reserve allocation significantly modified
- Control system solves “different problems” than real application needs (worse as active isolation is included)
- All above add risk of **OBSERVING DOWNTIME** when full-scale version is integrated at sites!

# Example: alignment control & stacks

## Equivalent SISO model

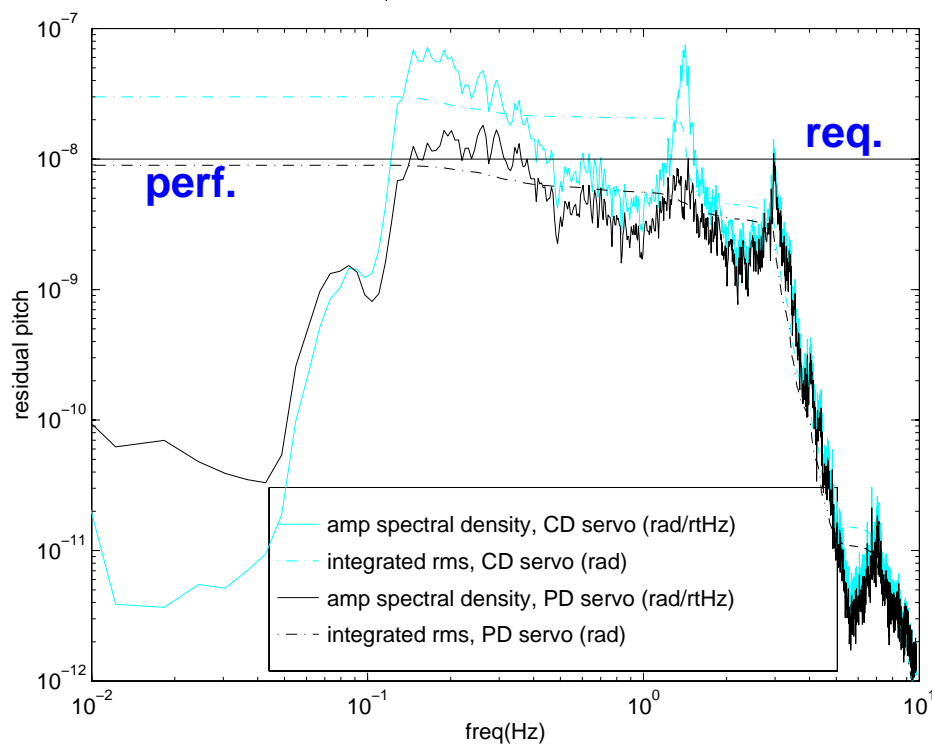
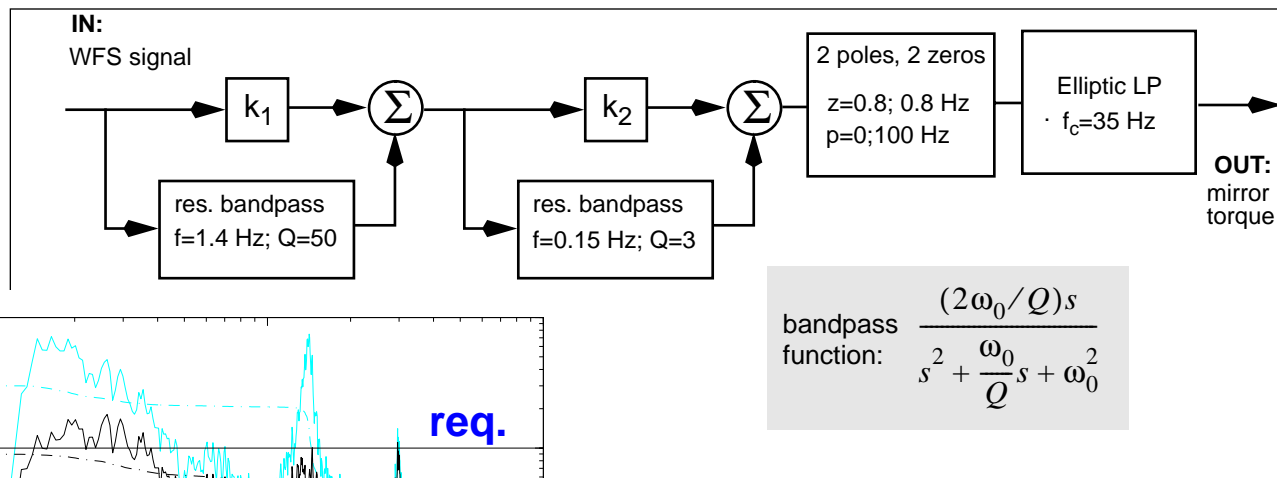

Performance vs. RMS residual requirement (end test mass pitch, Livingston seismic noise, Hytec Leaf Spring stack model)

# Opportunity Knocks: Building 20 Condemned! (film at 11)

---

- MIT LIGO group will move to NW 17 (across Mass. Ave.) early '98
- MIT will furnish a 4,000+ sq. ft. high bay
- Compatible with BSC and HAM, stacks, cleanrooms, etc.
- Cranes & power/cooling utilities to suit
- Additional steps (TBD) to reduce Cambridge seismic vibration background
  - New site is ~ as noisy as Building 20
  - Looking at civil, active options (Accentech/BBN)

# NW17 Location on MIT Campus

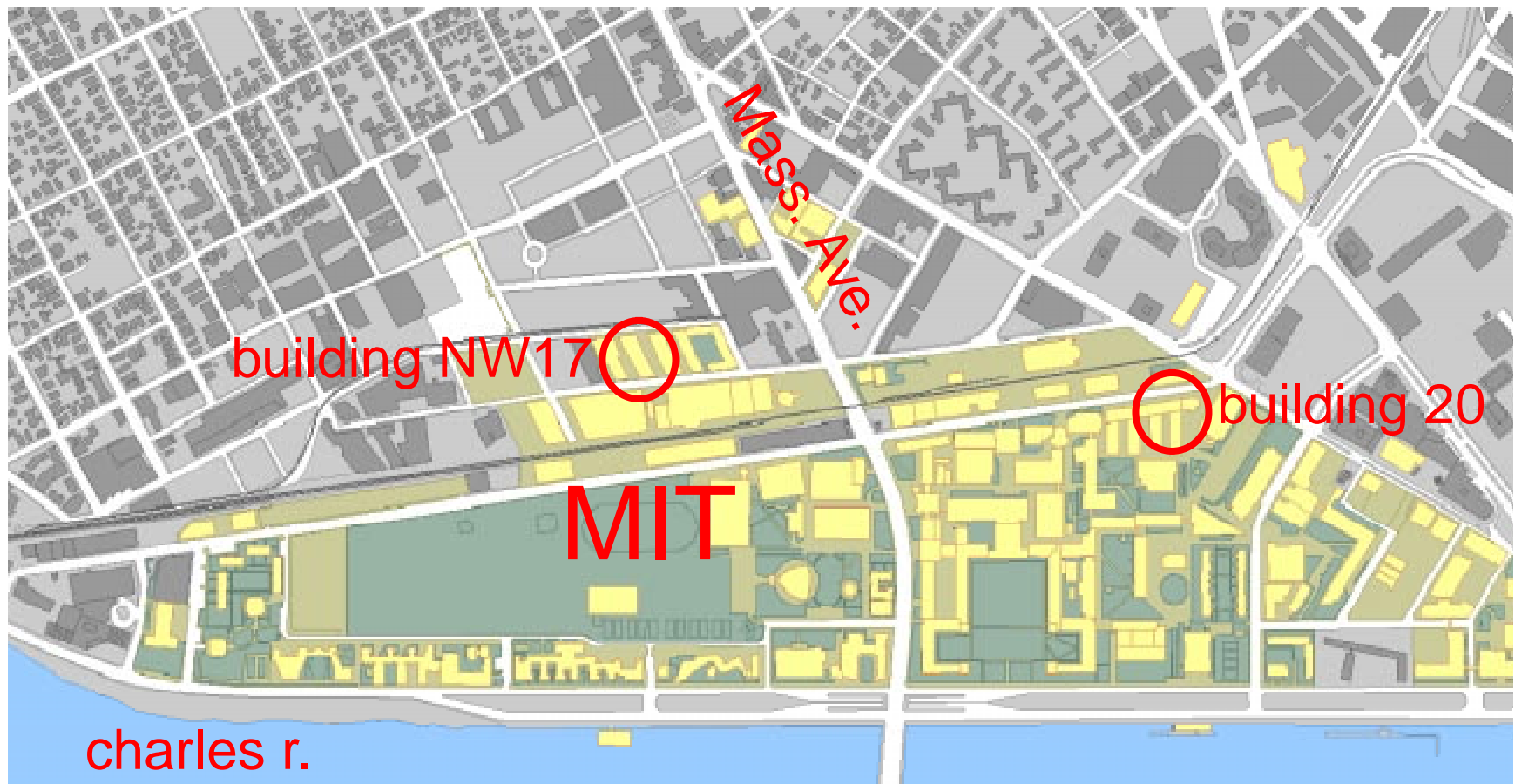

# Goal: “Plug-Compatible” Suspended Interferometer Testbed

---

- Exact duplicate of LIGO vacuum envelope, isolation, support components
- Provides **user facility** for LIGO collaboration
  - Final qualification step for upgrades (irrespective of origin)
  - Adds another suspended-interferometer testbed
    - > explore multiple advanced IFO options at once
    - > ‘divide, *scale appropriately* and conquer’ (e.g., phase noise + displacement noise)
  - Typical experiment to involve Laboratory, Collaboration contributors
- Build in two phases:
  - Phase I: one HAM, one BSC, 16.4 m baseline (double suspension tests)
  - Phase II: add two more HAMs for complete Michelson topology

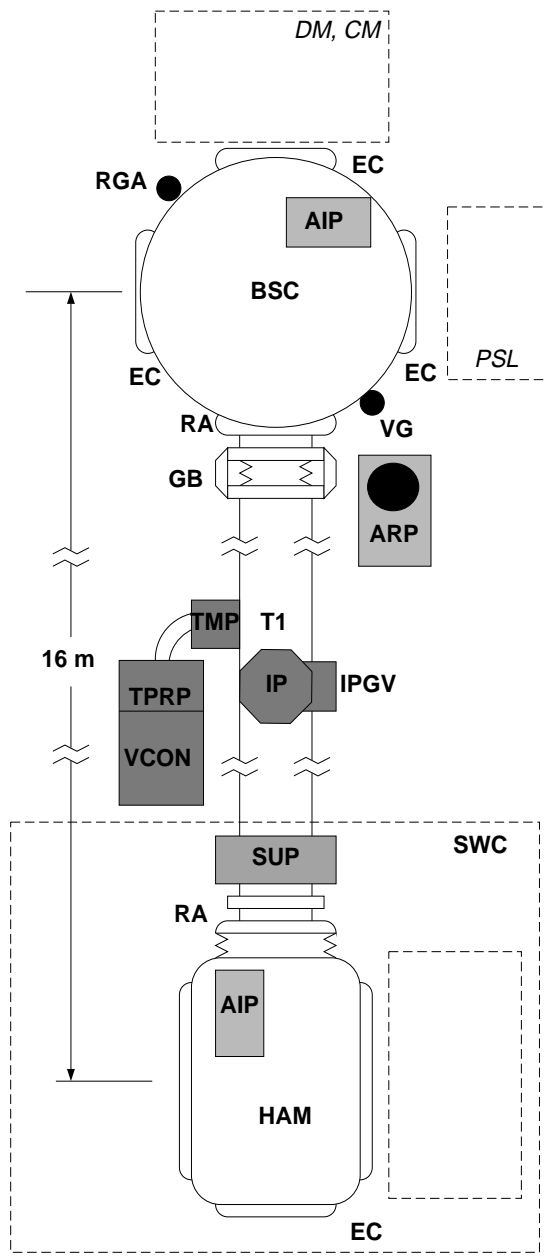

**MIT R&D Vacuum Envelope Concept: Phase I  
mez 5/15/97**

HAM	Horizontal Access Module
BSC	Basic Symmetric Chamber
EC	End cap (ported)
RA	Reducer A (60 X 48)
RB	Reducer B (84 X 48)
SUP	Tube support/thrust anchor
IP	Ion pump
IPGV	Ion pump isolation gate valve
T1-3	48" ID tube sections (ported)
TMP	Turbomolecular pump (valved)
TPRP	Turbo backing/roughing pump
VCON	Vacuum system control/monitor rack
AIP	Annulus ion pump
ARP	Annulus roughing pump (portable)
GB	Demountable gimbaled bellows, 48" ID
VG	Vacuum gauge set (valved)
RGA	Residual gas analyzer head (valved)
SWC	Softwall cleanroom (typ.)

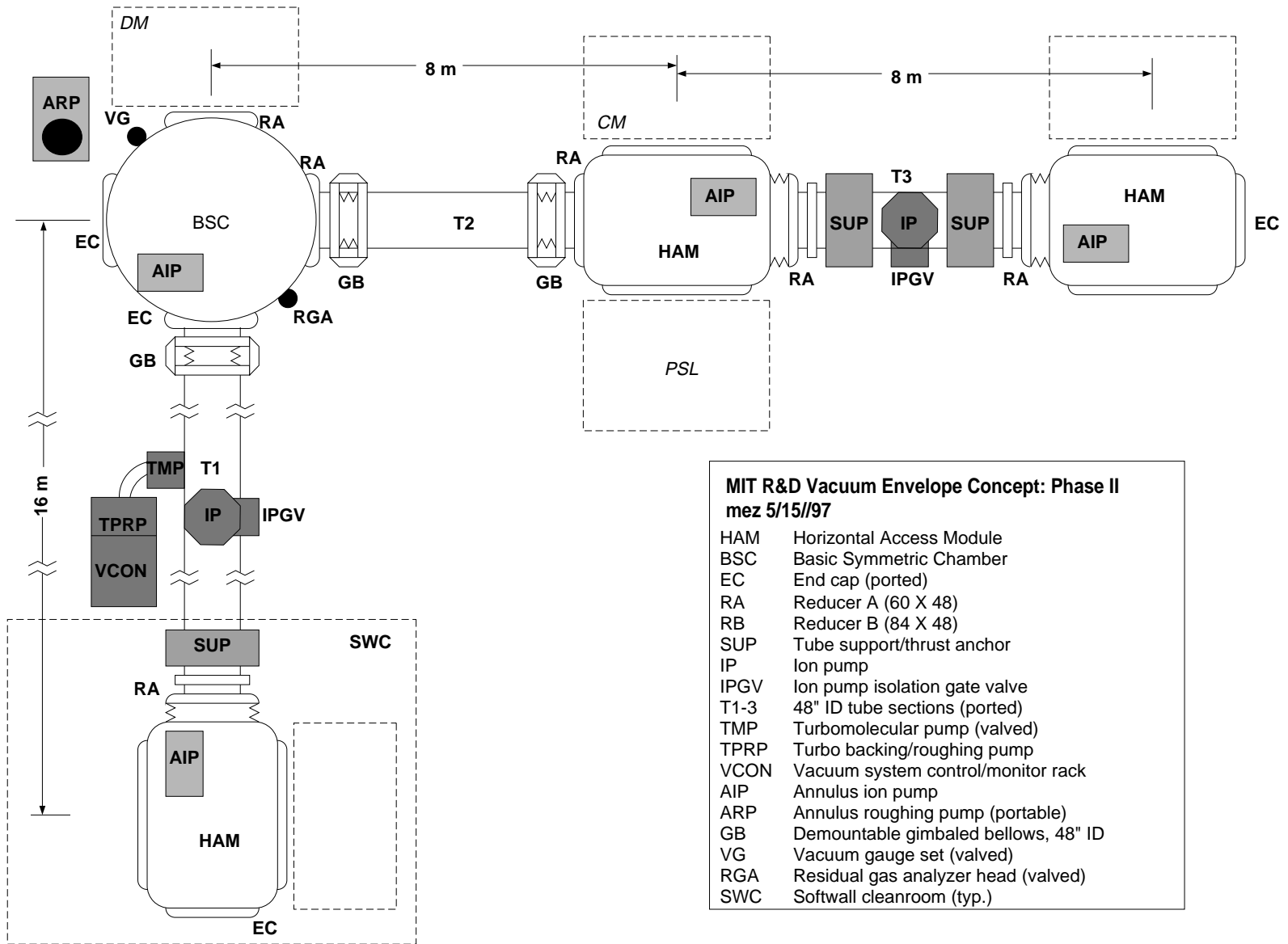



Symmes Maini & McKee Associates

1000 Massachusetts Avenue  
Cambridge, Massachusetts 02138  
617.547.5400 Fax 617.354.5758

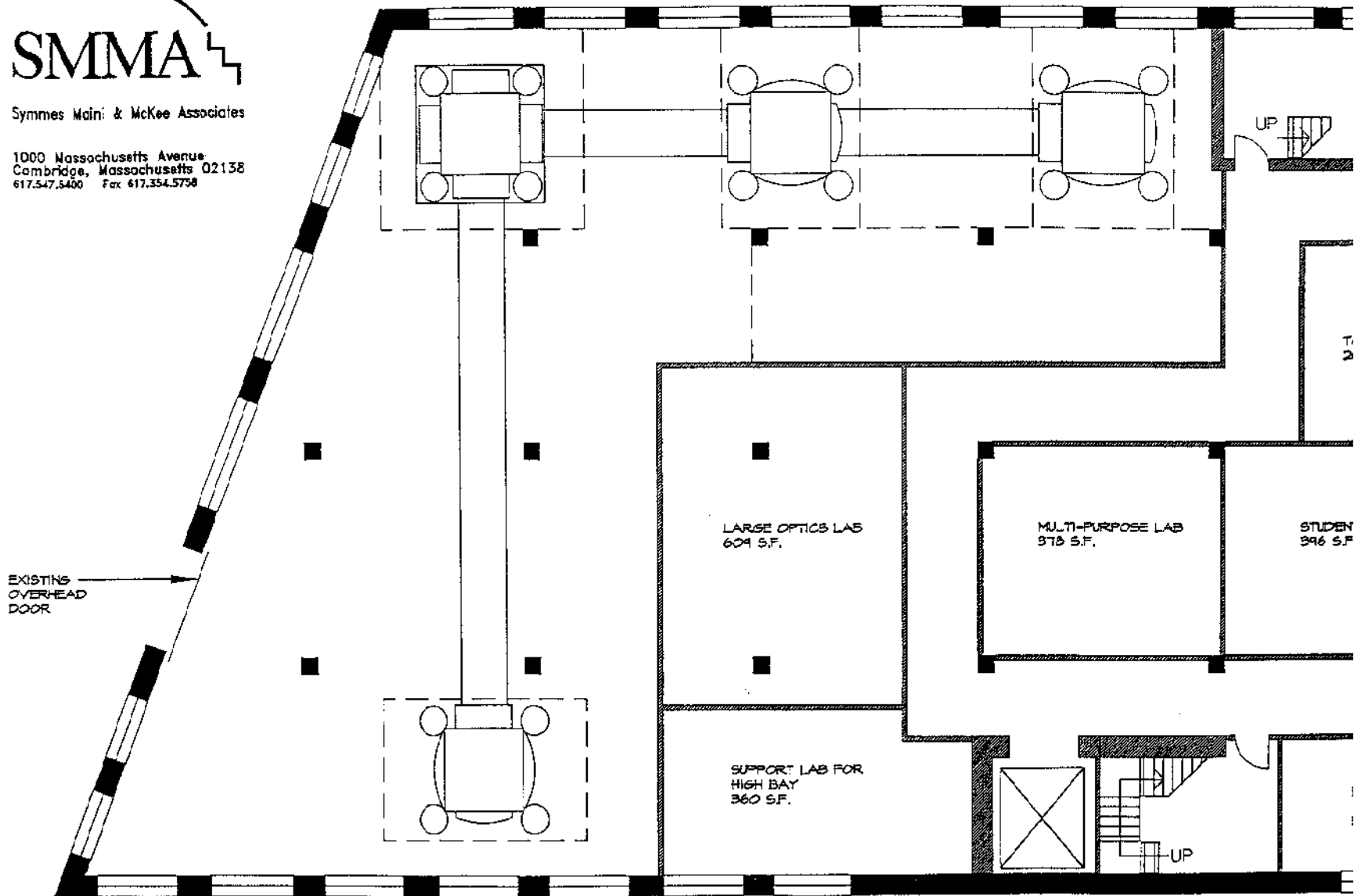

# Running the MIT Facility

---

- Priorities of Laboratory (peer-reviewed proposals) to be implemented by local manager & staff with collaborators
- Based on 40m & 5m models, expect 4-6 person team on typical experiment (more during construction/reconfig.)
- Continuity with tabletop precursor & support expt's, modeling/simulation 'vertical integration'
- 1-1.5 FTE associated with running facility, not attributable to experiment in progress (mgmt, engineering, project tech)
- need to achieve **short learning curve** for new trainees
  - good documentation, effective procedures, clear legacy
  - vigilant maintenance & upgrade program ('good enough' not good enough!)

# Timeline

---

- 11/97 - NW17 renovation begins.
- 1/98 - Lab move starts (offices, tabletop labs, computing net available immediately). PNI experiment completed.
- 3/98 - Lab move complete. Double suspension precursor experiments begin in tabletop lab. High bay available.
- 9/98 - MIT Phase I vacuum envelope shakedown.
- 1/99 - Double suspension tests start in new vacuum system
- 3/01 - Phase II vacuum envelope expansion complete, full-interferometer testing of enhanced subsystems begins
- 9/03 - Enhanced subsystem(s) qualified and ready for production and site installation