

Advanced LIGO Research and Development Status

NSF Annual Review of LIGO
Nov 9-11, 2005

Carol Wilkinson
LIGO Hanford Observatory

→ **Advanced LIGO is the LIGO Lab proposal for the next generation instrument to be installed at the LIGO Observatory**

Upgrade all 3 Interferometers and convert Hanford 2K to 4K Interferometer

- **Factor of 10 better amplitude sensitivity**
- **Factor of 4 lower frequency bound**
- **Factor of ~1000 greater volume and thus event rate**
- **Potential for tunable, narrow band searches**

Retain infrastructure, vacuum chambers, and Initial LIGO layout of power recycled interferometer

- Replace passive seismic isolation with multi-staged system with inertial sensing and feedback control
- Increase number of passive suspension isolation steps and use lower noise actuation
- Use lower mechanical-loss materials and construction in suspensions and optical coatings to reduce thermal noise
- Increase laser power ~20x and reduce optical losses to improve shot noise limits and signal strength
- Add GW signal recycling at output to increase sensitivity and allow narrow band frequency tuning.

ADVANCED LIGO LAYOUT

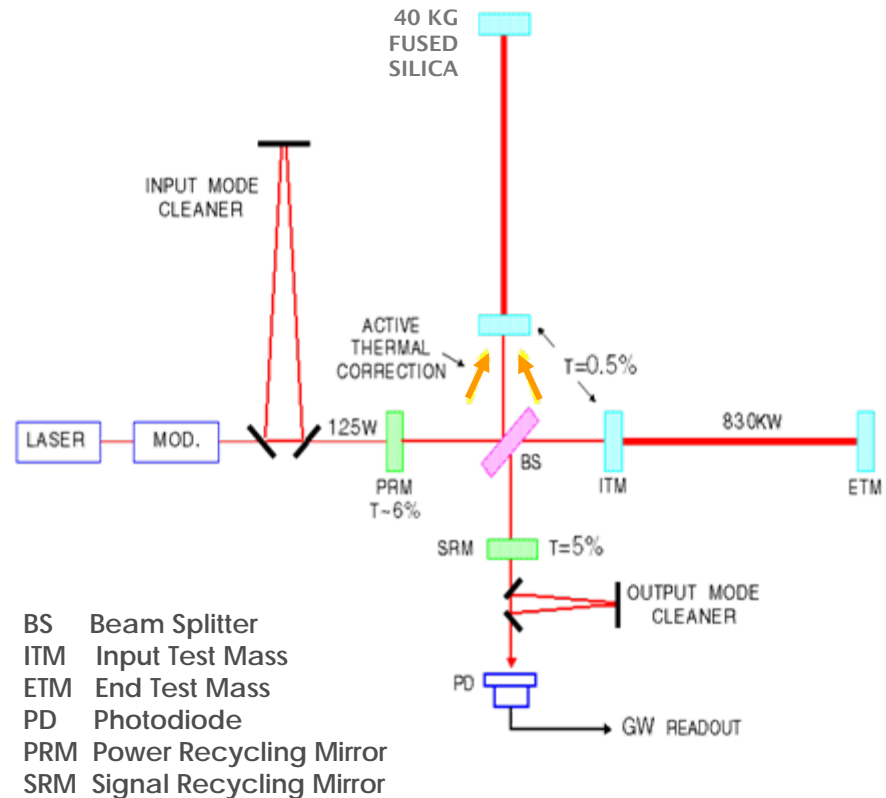

- Newtonian background, estimate for LIGO sites
- Seismic 'cutoff' at 10 Hz
- Suspension thermal noise
- Test mass thermal noise
- Unified quantum noise dominates at most frequencies for full power, broadband tuning

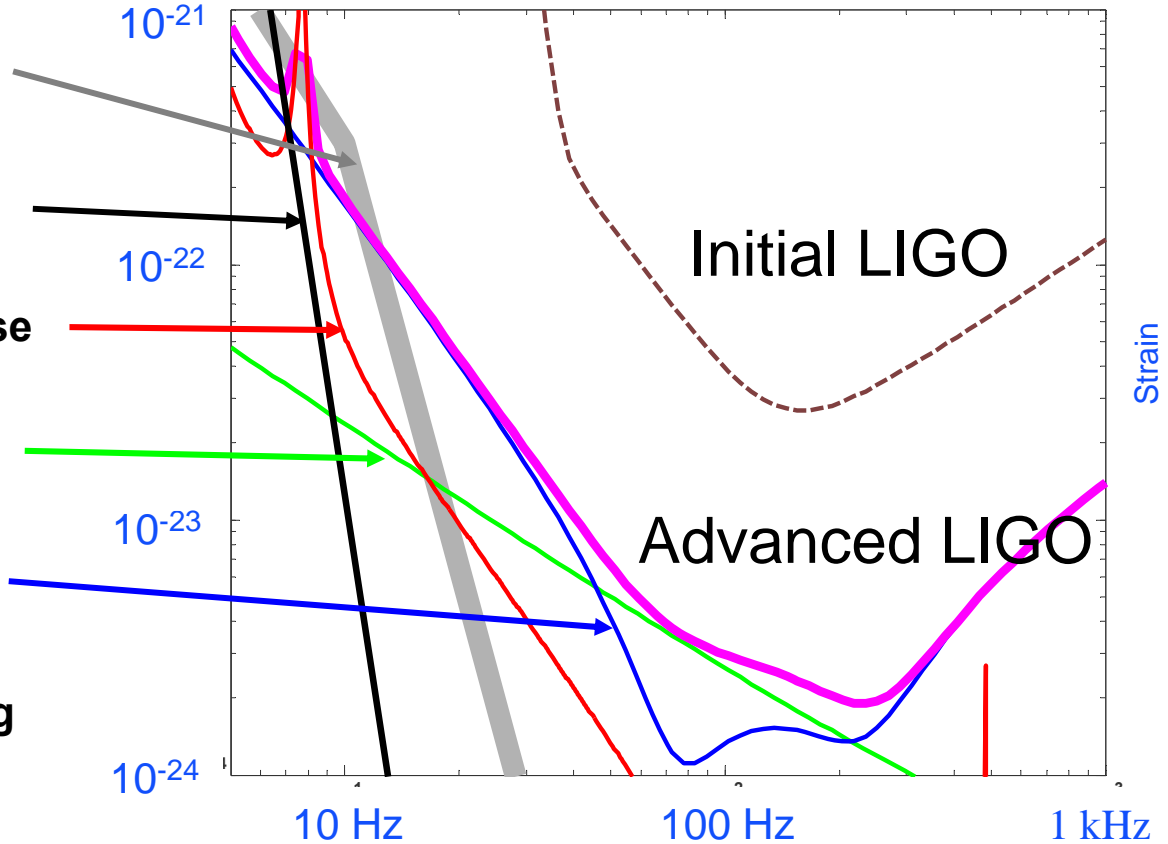

Principal noise sources and selected technical noise sources for Advanced LIGO

- **Distributed effort (multi-organization; multi-national)**
 - » Participants from LIGO Laboratory and LSC
- **Multiple funding sources**
 - » UK – PPARC/GEO funds granted thru construction (end in 2009)
 - » Germany – MPG/AEI funded thru construction
 - » Australia – pursuing funding options
- **Extended gravity wave community**
- **Project management methods and tools**
- **Evolving nature**
 - » Poised to move into construction project

Lead personnel organized by Subsystem or Support Function

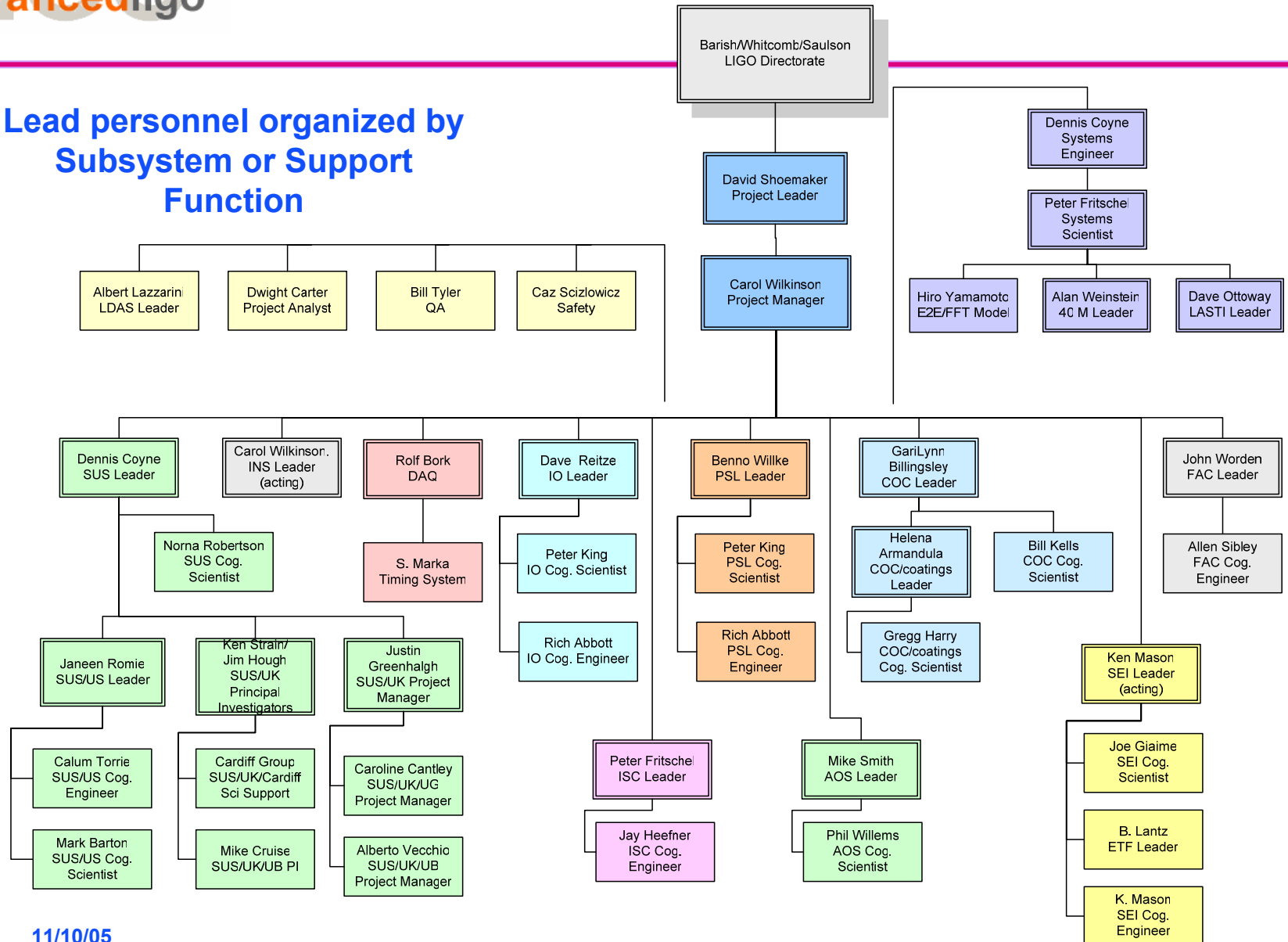



Gingin Facility



40 M Lab

- Two major LIGO prototype test facilities:
 - » **LIGO Advanced System Test Interferometer (LASTI)** @MIT – full scale tests of seismic isolation, suspensions, laser, mode cleaner
 - » **40m Interferometer** @Caltech – sensing/controls tests of readout, engineering model for data acquisition, software
- Support from LSC testbeds
 - » **Gingin Facility** @Gingin, Australia – thermal compensation (measure substrate absorption, test wavefront sensors & actuators), parametric instability
 - » **10m Interferometer** @U of Glasgow – readout
 - » **Engineering Test Facility (ETF)** @Stanford – seismic isolation
 - » **GEO600** @Hanover, Germany – much more than a prototype! (test of the quasi-monolithic fused silica suspension)
 - » **Thermal Noise Interferometer** @CIT – coating thermal noise
 - » **Initial LIGO** – much more than a prototype! (Hydraulic External Pre-Isolator (HEPI), Thermal Compensation System, Large Aperture, Thermally Compensated Faraday Isolator, ...)

Max-Planck Institute, Hannover leads the PSL development, working with Laser Zentrum Hannover and CIT

- **Injection locking of the 200 W Laser (LZH, AEI)**
 - » Demonstrated
- **Characterization of spatial and temporal behavior is underway**
 - » Developed diagnostic LIGO-like Pre-Mode Cleaner (PMC)

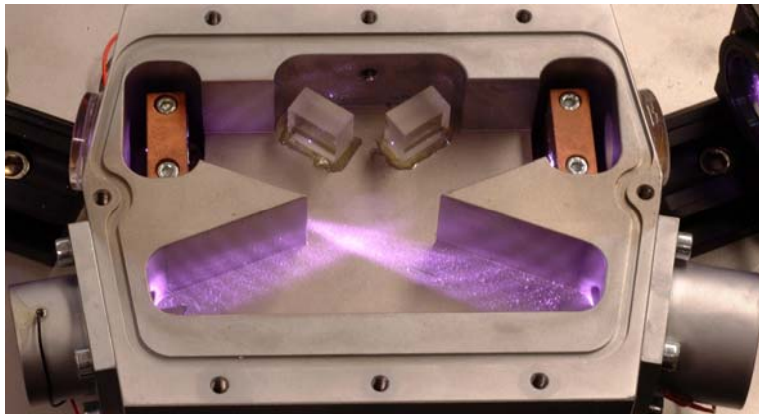
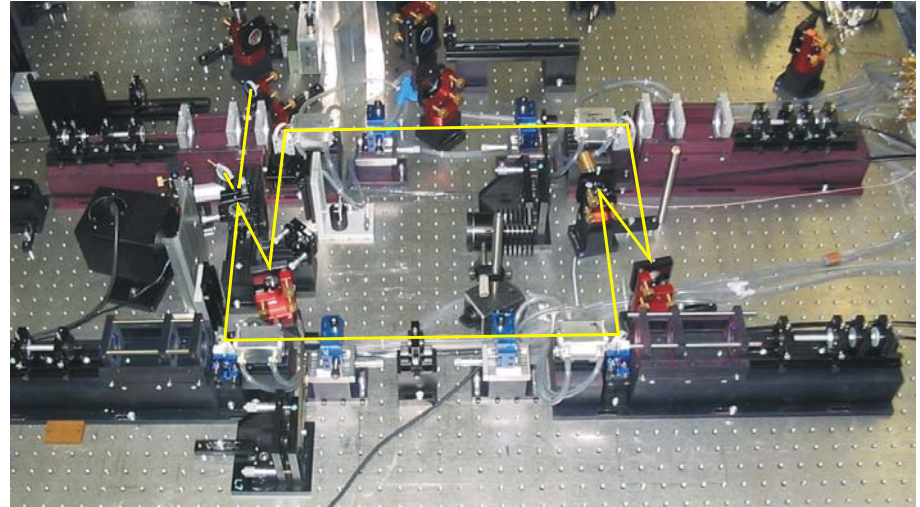

12 W Laser

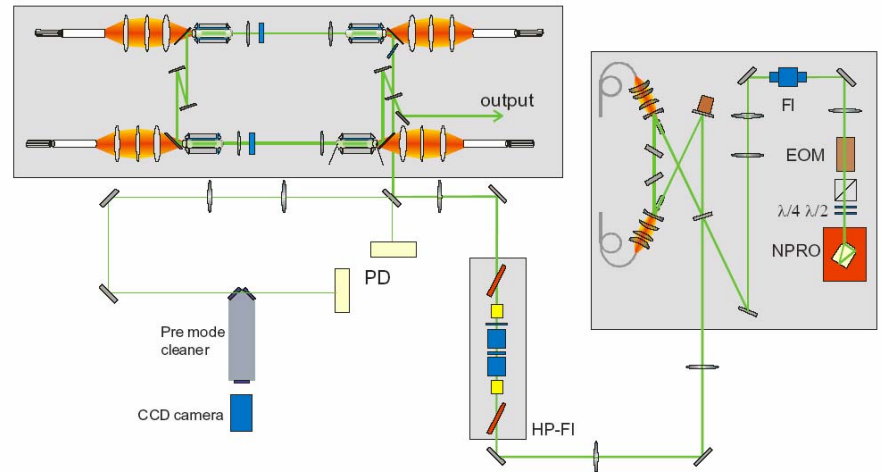

11/10/05

LIGO-G050575-00-M

- **Improved intensity stabilization at Hannover**
 - » Power noise reduced to within factor of 2 of req's
- **Studies of Relative Intensity Noise (RIN) Stabilization at GEO600 Interferometer**
- **Successful Requirements and Conceptual Design Review, March 2005**
- **Stress testing of photodiodes for intensity stabilization at Caltech**
 - » Damage threshold is above 600 mA for one minute
- **Max Planck Group has granted funds for delivery of all PSL's**

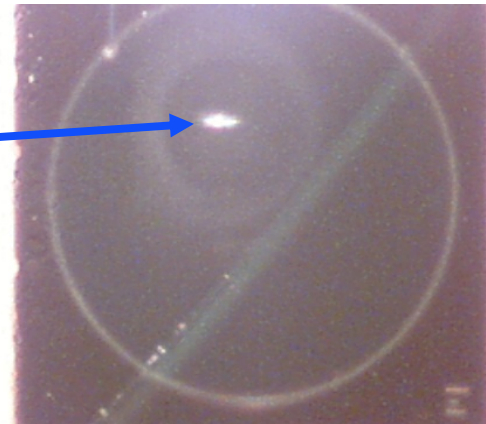
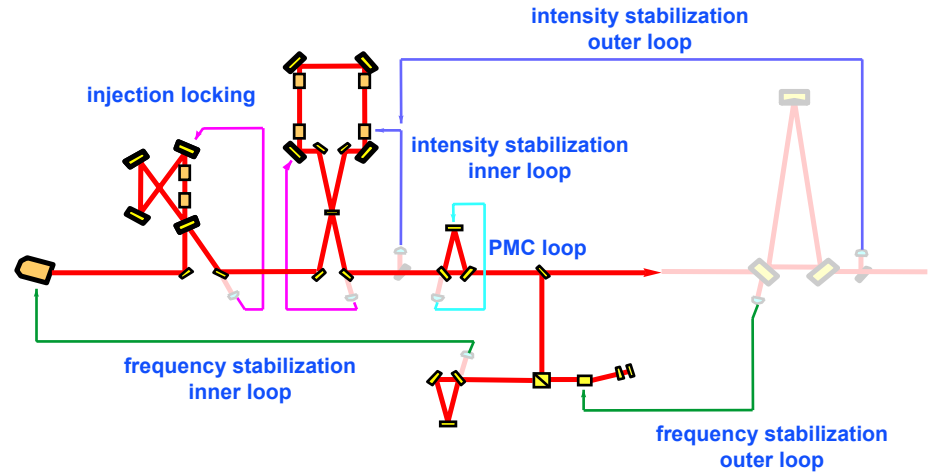

Active laser working group includes Stanford and Adelaide experts: maintains capability base

Lead by University of Florida, Gainesville

- **Faraday Isolators**
 - » Prototype Faraday isolators tested up to 100W
 - » Good isolation and passive thermal lens compensation

- **Mach-Zehnder modulation system**
 - » Analysis of noise couplings nearly complete
 - » Prototype MZ electro-optical modulator (EOM) locked and undergoing characterization

- **High power electro-optic modulators**
 - » Characterizing excess phase and amplitude noise
 - » No damage at 85 W for > 400 hrs at irradiances greater than for AdL

- **Adaptive mode matching telescope (MMT)**
 - » First generation MMT at UFL provides “Proof of principle” for dynamic focusing
 - » No measurable higher order mode contamination
 - » Implementing CO₂ laser as heating beam

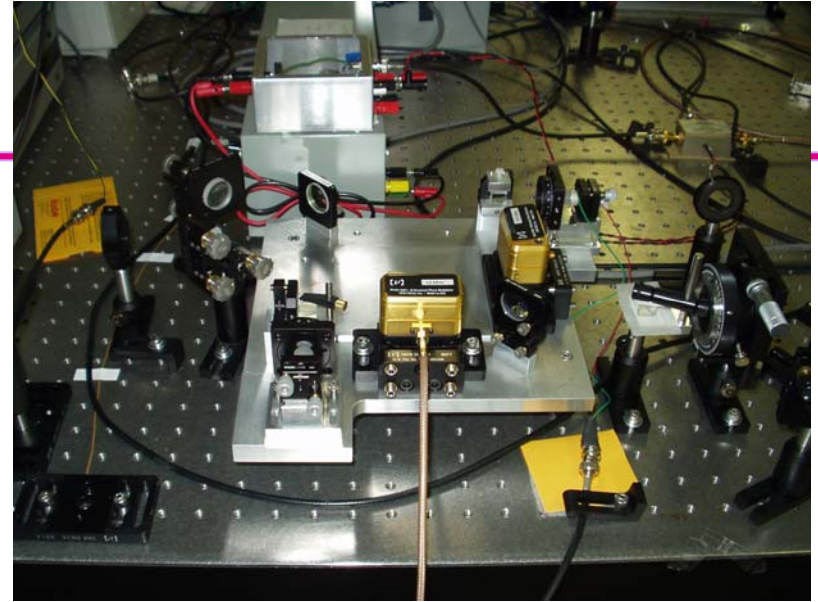

Mach-Zehnder Modulation

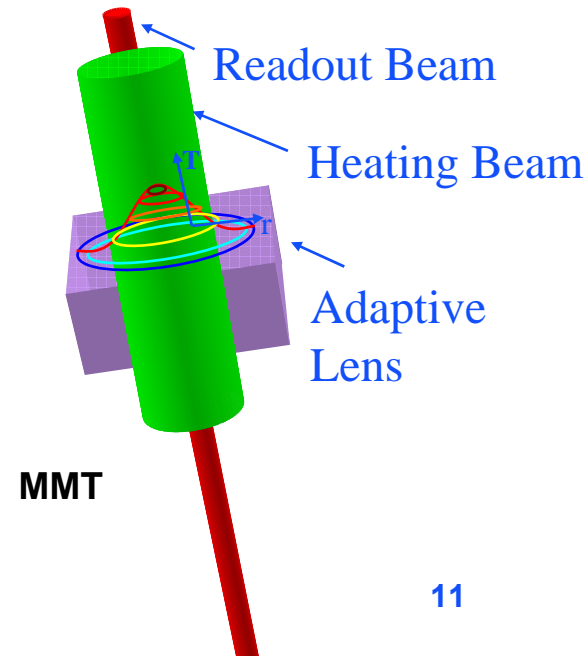

Combined CIT, MIT, Stanford, Glasgow efforts

- **Substrate selection = Fused Silica!**

- » Recommendation based on a comparative study
- » Either material could work, but more risks for sapphire
- » FS better at low frequencies (high mass BH-BH)
- » Sapphire better at high frequencies (LMXB)
- » Suspension design intended to be capable of future retrofit to sapphire if desirable
- » Coating mechanical loss dominates

- **Continuing Fused Silica studies:**

- » Annealing
- » Scatter and absorption characterization of Initial LIGO optics H1 ITM
- » Developing cleaning procedures and determining required particulate cleanliness levels

	Sapphire	Silica
NS-NS 1.4 Ms	191 Mpc	191 Mpc
BH-BH 10 Ms	920 Mpc	1050 Mpc
Pulsar $h/\sqrt{\text{Hz}}$	7×10^{-24}	12×10^{-24}
Omega	4.8×10^{-9}	2.6×10^{-9}

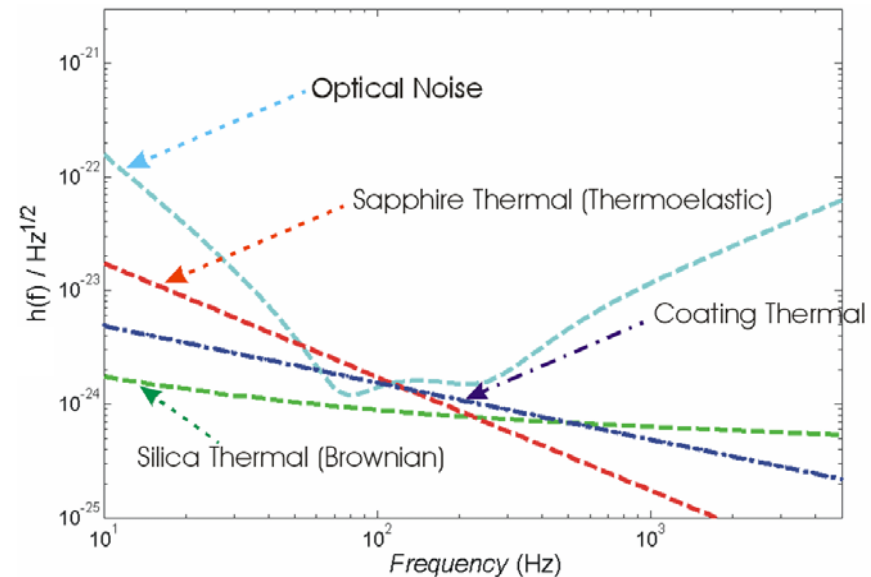

- Pursuing “pathfinder” studies with fused silica substrates
 - » Substrate for LASTI ‘noise prototype’ quad suspension acquired
 - » UK funded “**First articles**” (4 ITM blanks, Heraeus 311) arriving in January
 - » Refining polishing specs for Advanced LIGO core optics
- Initiating electrostatic charging study via Kelvin probe measurements
 - » LSC efforts combined with input from LISA studies; plan prepared
 - » Trinity Univ. doing measurements with loan of LIGO equipment
 - » Initial results indicate that the basic sensor works
- Gaining experience in thermal compensation with initial LIGO implementation

(CIT, MIT, Lyon LMA, CSIRO, UG, Stanford Efforts)

Goal: Reduce initial LIGO loss angle, bringing coating thermal noise below optical noise

- Thermal Noise Interferometer (TNI) verifies reduction in thermal noise from TiO_2 doped Ta_2O_5
 - » Broad optimum concentration
 - » Results in good agreement with Q measurements.
- Studying absorption and scatter to ensure all requirements met simultaneously
- Could build ‘good enough’ interferometer with tweaking of present materials and process
 - » Pursuing potential improvements and understanding

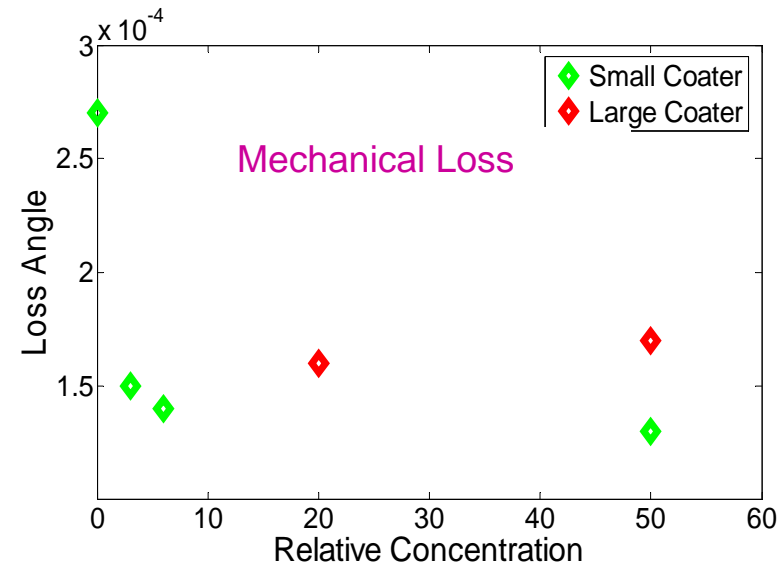

Concentration of TiO_2 in Ta_2O_5



“Improvements lead to expanded range”

- **Parametric instability**
 - » Coupling of internal test-mass mechanical resonances and higher-order optical modes of arm cavity

- **Working group formed LSC-wide**
 - » Perth, CIT, Embry-Riddle, MIT, ...

- **Gaining experience and understanding of potential impact for advanced LIGO**

- **New results from ACIGA-LIGO collaboration**
 - » Beginning to see effects in modeling and in the lab

- **Active and passive mitigation approaches proposed for testing at Gingin and TNI**

Mechanical mode
47.27 kHz

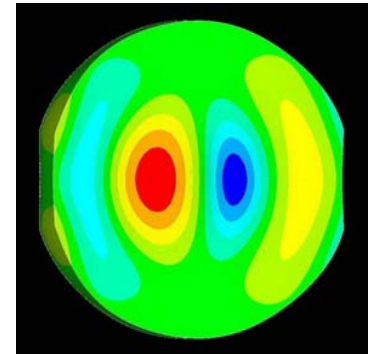

Optical mode

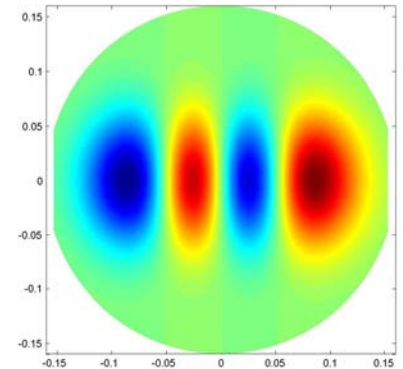

Overlap: 0.800



'Controls' Triple Installation at LASTI

Combined US/UK Effort



- **Mode Cleaner (Triple) Suspension**
 - » LASTI testing of 'controls' prototype showed performance as expected
 - » Noise prototype will be built in 2006
- **Test Mass (Quad) Suspension**
 - » Joint design effort by US and UK
 - » 'Controls' prototype bench tested at CIT
 - » Being prepped for shipping to LASTI for testing
 - » 'Noise' prototype and final design led by UK (U. Glasgow, U. Birmingham; Rutherford Lab; concurrent with 'controls' prototype testing)
- **Electronics preliminary design review in progress**

- **Silica Fiber/Ribbon Pulling**
 - » R&D on CO₂ laser system proceeding well
 - » Assembling final stage prototype of fiber fabrication machine
- **Fiber/Ribbon Welding**
 - » Fiber & ribbon welding demonstrated
 - » Laser welding being further developed
- **Ears and Silica Bonding**
 - » Adapting designs used in GEO600 interferometer for Advanced LIGO application

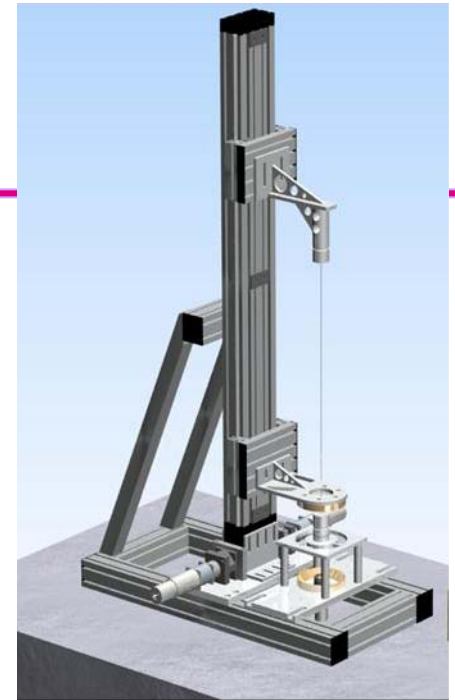

Fiber pulling fixture

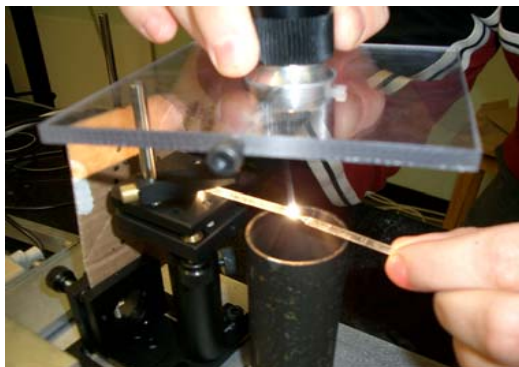

Welding silica rod with 9W CO₂ laser

- **Fiber/Ears/Bonding PDR held in October, 2005**
 - » Waiting for panel report before proceeding with final designs

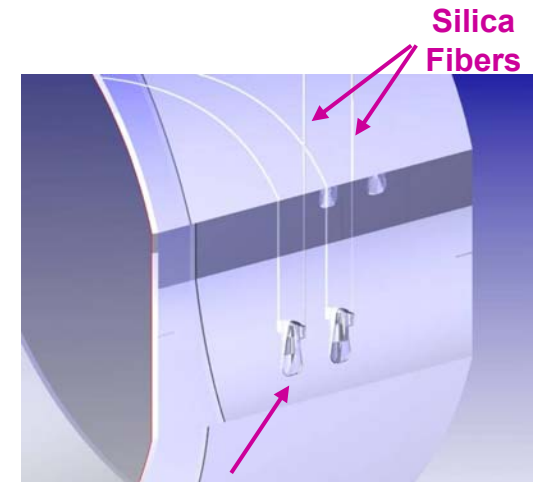

Ears bonded to fused silica substrate

Combined effort: LSU, Stanford, CIT, and MIT

- Full scale seismic isolation prototype for the test mass chambers (BSC) in production
 - » Significant progress in performance and understanding of Stanford prototype
 - » Analysis of coupled SEI-SUS dynamics indicates effect is manageable
 - » Tuning design to meet requirements
 - » Critical design review recommends proceeding with fabrication of prototype

- Installation and testing at LASTI in ~1 year

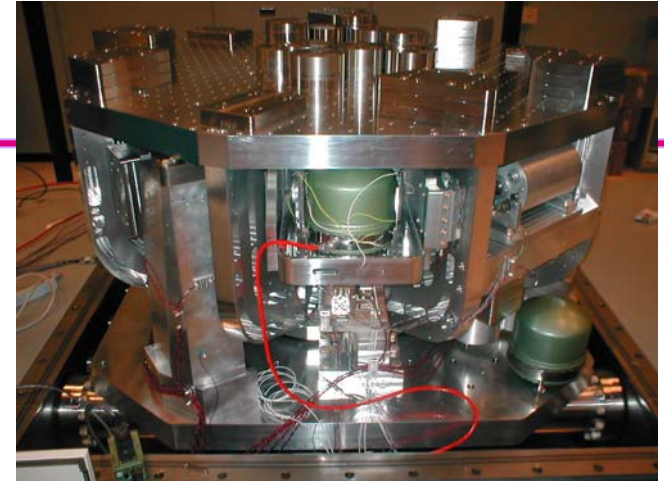

SEI Technology Demonstrator @ Stanford Engineering Test Facility (ETF)

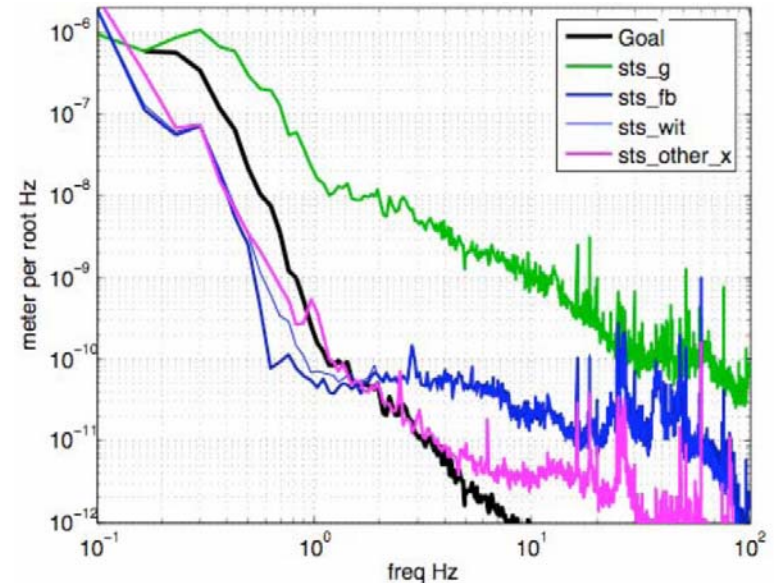

- **Next focus is on the auxiliary optics chamber (HAM) seismic isolation design**
 - » Have a conceptual design
- **Reviewing the requirements**
 - » Present requirements equal to those of test mass chamber, but
 - » Instruments less sensitive to motion in the auxiliary chambers, leaving room for relaxed requirements
 - » May allow a design with lower cost and complexity
- **Comparing several design approaches**
 - » Current realization ('ETF') or a design more similar to the BSC Single-stage system with lower cost and complexity
 - » Passive isolation similar to VIRGO interferometer technology

Combined effort: CIT and MIT

- **Systems Engineering**

- » Starting an integrated 3D opto-mechanical layout
- » E2E Adv. LIGO modeling well underway
- » Systems trades & Requirements/Interface definition proceeding

- **Controls and Diagnostic Systems**

- » Development and implementation of control systems for LASTI suspension and seismic isolation testing

- **40M Tests of Controls**

- » Lock acquisition of dual recycled interferometer
- » Length sensing and control scheme for resonant sideband extraction
- » DC gravity wave readout scheme
- » Verify optical spring and optical resonances
- » Test simulations for extrapolation to advanced LIGO
- » Explore modulation techniques such as Mach-Zehnder design

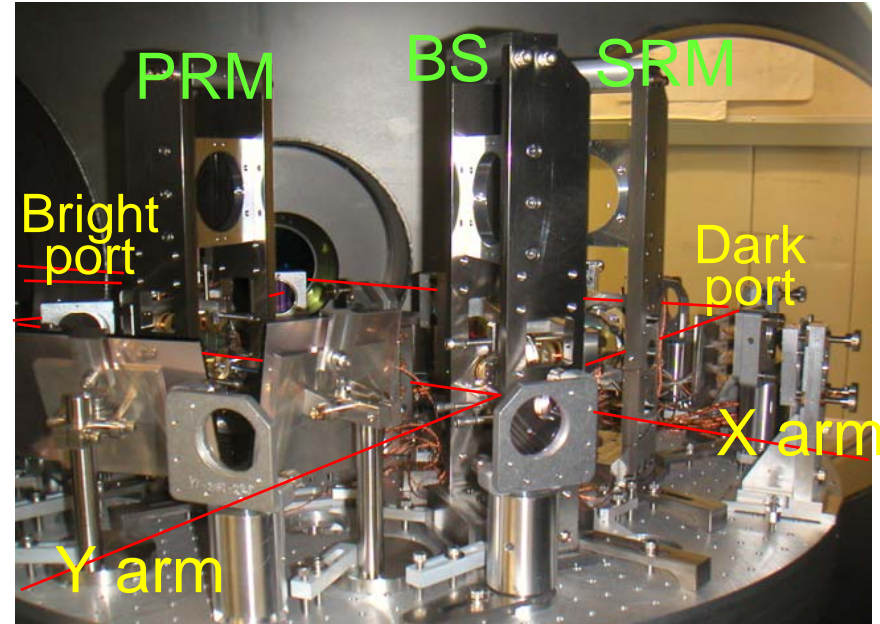

40M beam splitter chamber

- The dynamic R&D organization in LIGO and the LSC has resulted in mutual benefit between initial and advanced LIGO.
- Continuing this tradition will benefit initial LIGO, Advanced LIGO, and any future detectors

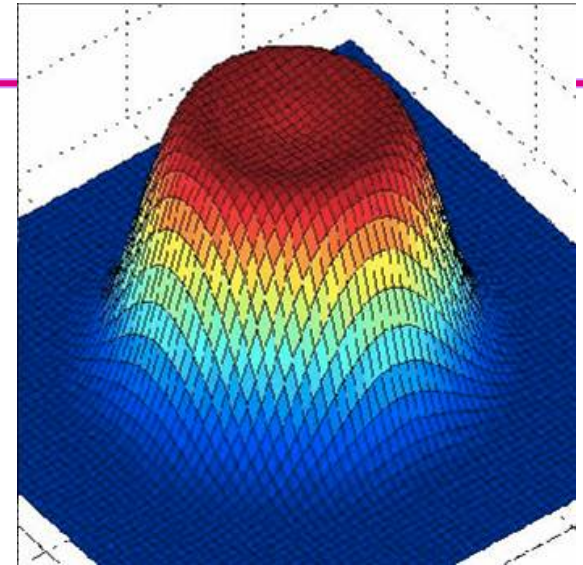

Simulated flat top beam

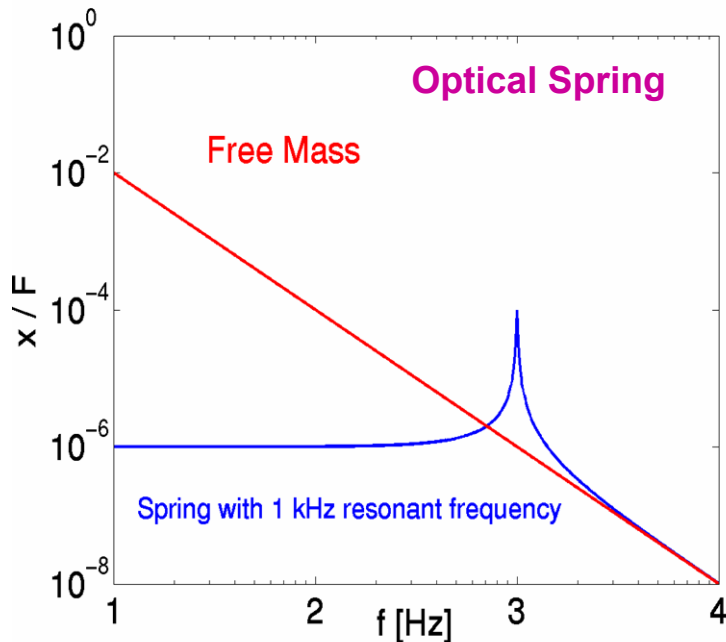

Examples:

- Optical spring
- Flat top beams
- Light squeezing
- Variable transmission recycling mirror at Gingin

- **Sapphire/Fused Silica downselect**

- » *“While both choices for the test mass substrates, fused silica or sapphire, appear to satisfy the Advanced LIGO science requirements, it is very important to make a decision soon so that other design efforts can go forward.”*

- **Done. Fused silica chosen**

- **Coating mechanical properties**

- » *“The mechanical properties of the optical coatings for the optical elements in LIGO remain a concern for Advanced LIGO. The Panel is pleased with the strategy that is being followed to resolve this issue.”*

- **Have achieved a result that would work, but working for more**

- **Electrostatic charging**

- » *“The Panel encourages the continuation of the investigation of the effects of electrostatic charging of the mirror surfaces and the mitigation of these possible effects on the performance of the Advanced LIGO interferometers.”*

- **Collaborative efforts underway**

- **Foreign contributors**

- » *“The active participation of the foreign collaborators in Advanced LIGO is an essential element of the Advanced LIGO construction project. The Panel is pleased to note that PPARC has already awarded the funds for the suspension system and some optical elements and that the collaborators in Germany are well along in securing the funding for the high power lasers.”*
 - PPARC funds awarded for suspensions and some core optics
 - MPG funds for PSL now awarded
 - Seeking Australian funds for output mode cleaner development and high power testing

- ❖ **"Noise squeezing"**

- » *“As a possible improvement to the performance of Advanced LIGO, the Panel encourages the LIGO group to continue exploring noise squeezing techniques developed by outside groups and participating in the testing of these techniques possibly at the 40 m.”*
 - Techniques developed by ANU and others incorporated into LIGO Quantum Measurements Lab and further developed by LIGO for GW implementation
 - Working on a test plan for the 40M

- **Advanced LIGO development work organized into Work Breakdown Structure**
 - » Schedule is integrated across subsystems
 - » Bi-monthly progress updates
- **Majority of subsystems are in the preliminary design phase**
 - » Fabricating and testing prototypes (SEI, SUS, COC, PSL, IO)
 - » In one case, final design starting (UK effort on test mass quad suspensions)

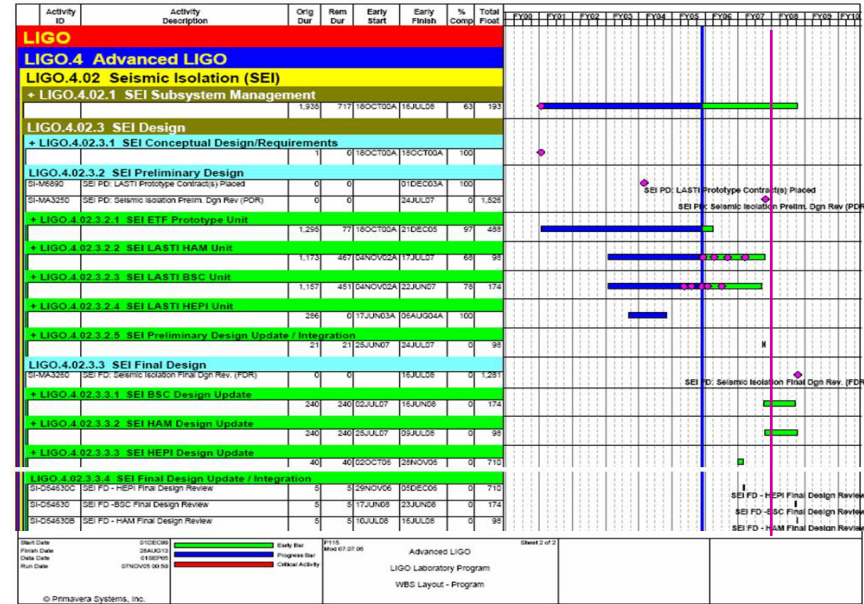

Seismic Isolation Development Schedule

- **Some subsystem components ready for procurement in FY2007**
 - » E.g. External pre-isolator (HEPI), optics, triple and quad suspensions, ...
- **All components ready for procurement by FY2009**
 - » Exception: just-in-time procurement of computing and data acquisition components for return to operations

- **President's budget calls for FY2008 funding start**

- » Contingent on indication that we are achieving Initial LIGO goals!

- **Baseline plan minimizes time 'off-line' for science running**

- » Stockpile equipment until 'procurement' does not constrain installation
 - » First Initial LIGO detector shut down in mid-2010, with third AdL detector accepted at end FY2013

- **Some design to occur after funding start, in parallel with FY2008 procurement and fabrication**

- » Late-stage final design, minor modification of existing LIGO designs, just-in-time definition of off-the-shelf components
 - » Subsystem integration and testing to hone installation and acceptance testing procedures as well as train personnel (Schedule risk reduction)

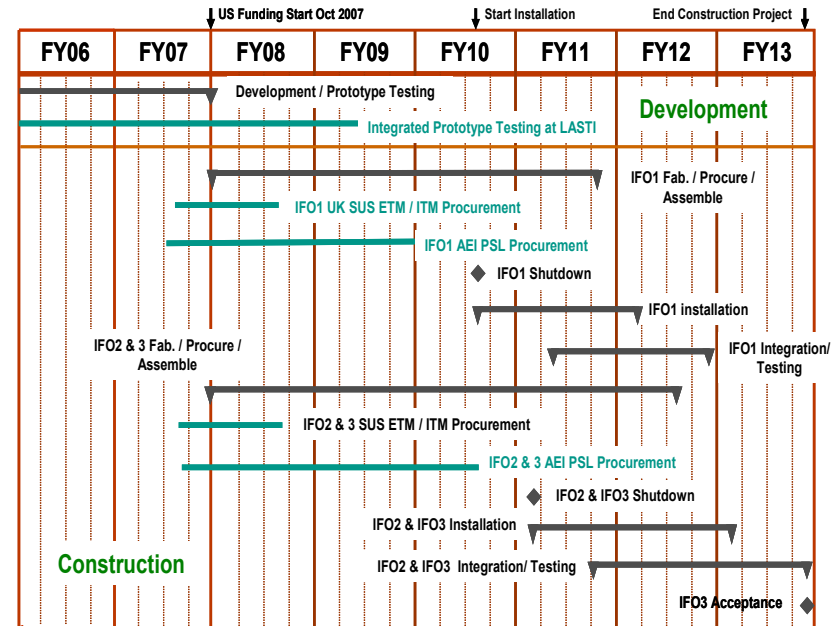

Advanced LIGO Project Schedule

- **Seismic isolation systems are the critical path for development (technology optimization)**
- **Some design to occur after funding start, but all design finished by FY2009**
- **Aggressive project funding profile**
 - » Requires ~\$148M out of ~\$185M in first 3 years in response to NSF request to delay start to 2008 and keep a 2013 finish date.
- **Development is being managed and coordinated**
 - » Could start purchase of long-lead items in FY2007 (HEPI, optics, suspensions)
- **On track for FY2008 construction start**