



What Should We Do To H2 in AdLIGO?

Fred Raab,
LIGO Hanford Observatory

The Question

AdLIGO Proposal envisaged:

Initial LIGO		→	AdLIGO	
H1.1	Broadband 4 km		H1.2	Broadband 4 km
H2.1	Broadband 2 km		H2.2	?? 4 km
L1.1	Broadband 4 km		L1.2	Broadband 4 km

What is the mission of H2.2 and should it be 4-km long?

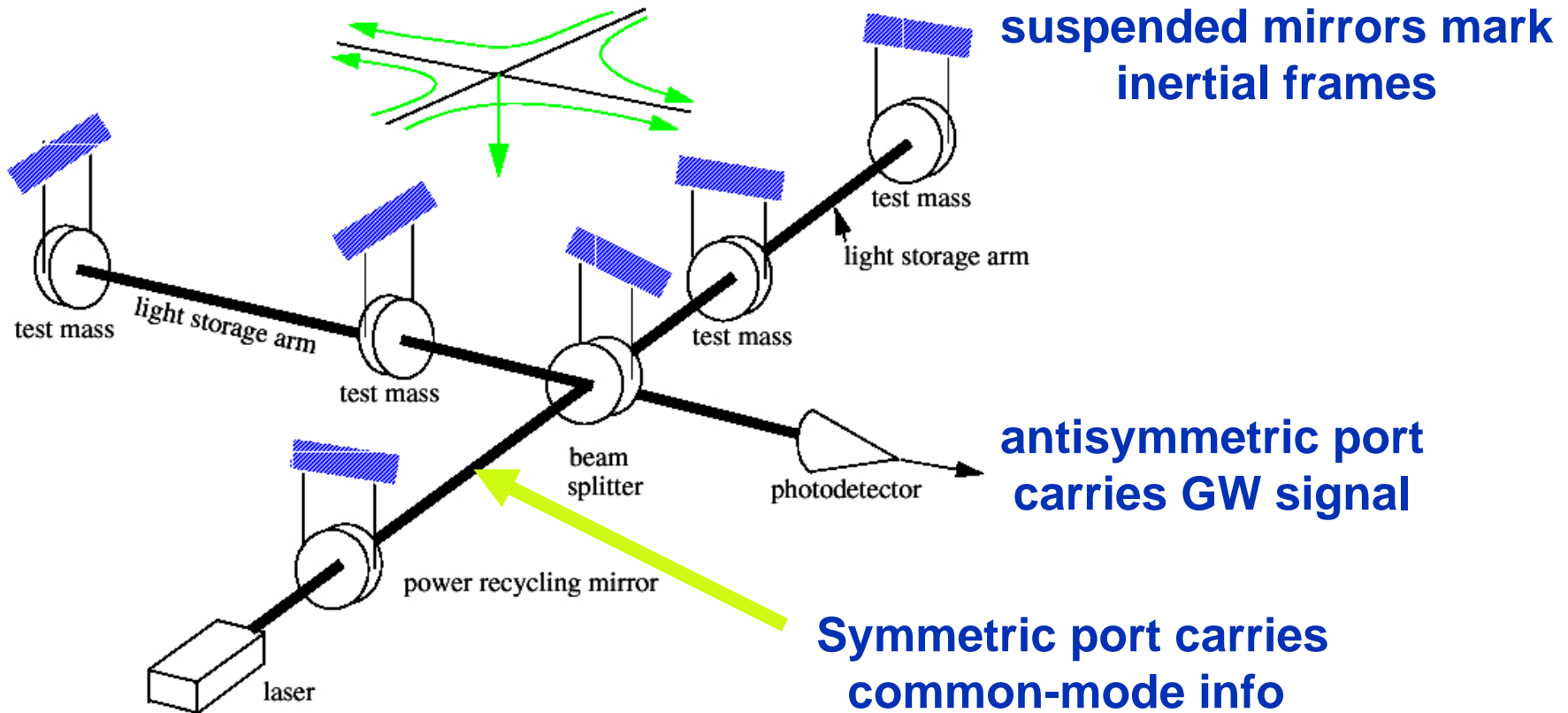

Ordered a 4-km @ each site + a 2-km additional @LHO

Thinking ca. 1989: why triple coincidence was necessary

- Expected double coincidence would not be able to deal with non-stationary noise “bursts”
 - » Experience was that large noise bursts (relative to stationary noise standard deviation, σ) were frequent occurrences
 - » Burst rates were high in single interferometers (many/minute)
 - » 30σ to 100σ bursts and higher were quite common
 - » Getting down to gaussian noise level of instruments in a GW burst search with low false alarm rate ($\sim 0.1/\text{year}$) required very low singles rates ($\sim 1/\text{hour}$) with only double coincidence
 - » But as singles rates of noise bursts decrease, time to find mechanisms increases
 - » Triple coincidence could tolerate noise burst rates $\sim 100\times$ larger and still meet expectations for rare GW burst detection

Thinking ca. 1989: is there any advantage to co-location?

- Certainly/Maybe

- » Co-located interferometers with similar response HAVE FAR TIGHTER COINCIDENCE WINDOWS (in time, waveform and amplitude) and reject noise bursts far more effectively ($\sim 5\times$) than distant interferometers, PROVIDED THEY ARE NOT CORRELATED
- » Co-located interferometers are CAPABLE OF BETTER STOCHASTIC LIMITS ($\sim 5\times$), because they can accumulate signal coherently over the entire sky at higher frequencies where there is less instrumental noise, PROVIDED THEY ARE NOT CORRELATED

Thinking ca. 1989: why make 3rd interferometer half as long?

- For triple coincidence to be effective:
 - » Optimize similarity of response to GW
 - » Mitigate correlated noise in co-located interferometers
- Options
 1. Build co-located 4-km interferometers that have no correlated noise
 2. Try a 2-km and a 4-km on for size
 3. Depend on someone else to build a similarly sensitive interferometer elsewhere
- Option 2 looked like the least bad option
 - » Option 1 was not credible
 - » Felt we could not depend on option 3

Does a 2-km interferometer help with correlated noise

- Maybe yes, maybe no, depending on mechanism
 - » For acoustic emission in suspended mirrors, hiccups in lasers, and other “component” noise sources, there is no intrinsic correlation so length is not an issue
 - » For a large, highly-localized impulsive event from the environment, like a “gas burst” in the beam tube, or a “dewar burst” in an end station, the co-located interferometers probably will not respond the same to noise burst as to a strain
 - » For certain noise sources, like acoustic or seismic coupling to the ex-vacuo optical trains in the corner station, it is tough to beat low-level correlation
 - Nonetheless, coupling of correlated noise could be different in ratio than for strain

Does a “half-length” interferometer cost a factor of 2 in sensitivity

- Depends on search:
 - » **Bursts:** with differential thresholding, Drever, Gursel and Tinto found a 3-detector network with twice the strain equivalent noise in one detector is $1.3\times$ less sensitive than when all three have equal noise
 - » **Inspirals:** expect this case to follow bursts
 - » **Periodic:** expect this case to follow bursts for detections
 - » **Stochastic:** not applicable to H1•L1 limit; for H1•H2 limit, expect to suffer a full factor of $2\times$ loss in sensitivity from case of correlating two 4-km interferometers that have no instrumental correlations; in presence of instrumental correlations, strain sensitivity may be an important constraint helping to mitigate correlation

How has history played out?

- There is still no third interferometer of comparable sensitivity to H1 and L1 across the band
- There typically have been large differences in science-run sensitivity between H1, H2 and L1 for commissioning reasons
- Triple coincidence has been an essential element of burst and inspiral searches
- Periodic searches have concentrated on upper limits and noise is stationary on their long integration times; typically the most sensitive interferometer dominates the limits by a wide margin
- No search to date has fully pushed amplitude thresholding to optimization

Major technological differences between LIGO and Advanced LIGO

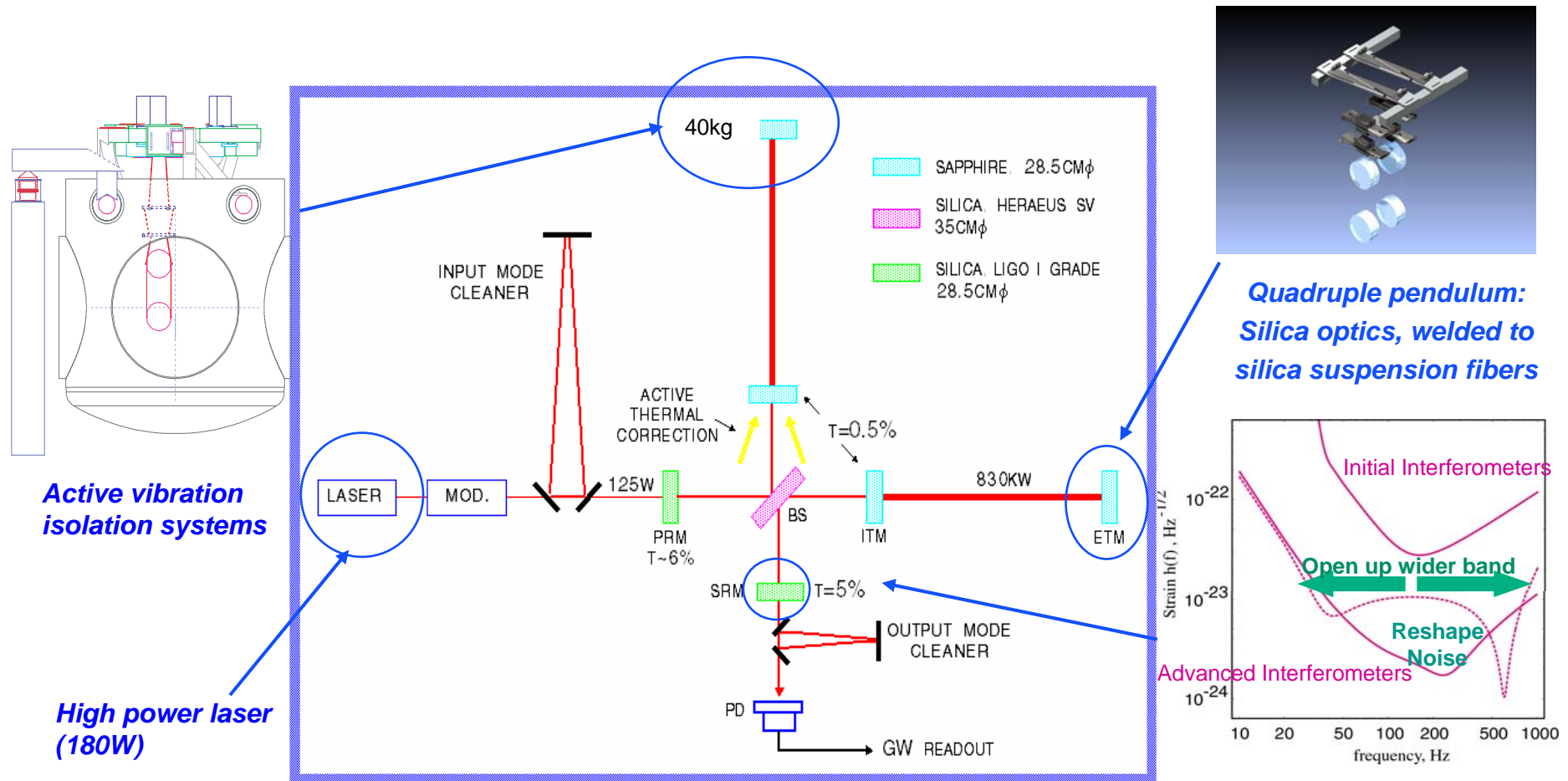

Active vibration isolation systems

High power laser (180W)

Quadruple pendulum: Silica optics, welded to silica suspension fibers

Advanced Interferometers

Advanced interferometry
Signal recycling

AdLIGO Options for H2

- Stretch to 4 km or leave at 2 km
- Operate with similar bandwidths to H1, L1 to optimize triple coincidence useage
- Operate H1, L1 as broadband interferometers in double-coincidence mode and operate H2 in a specialized search mode

Example of a possible optimization for H2

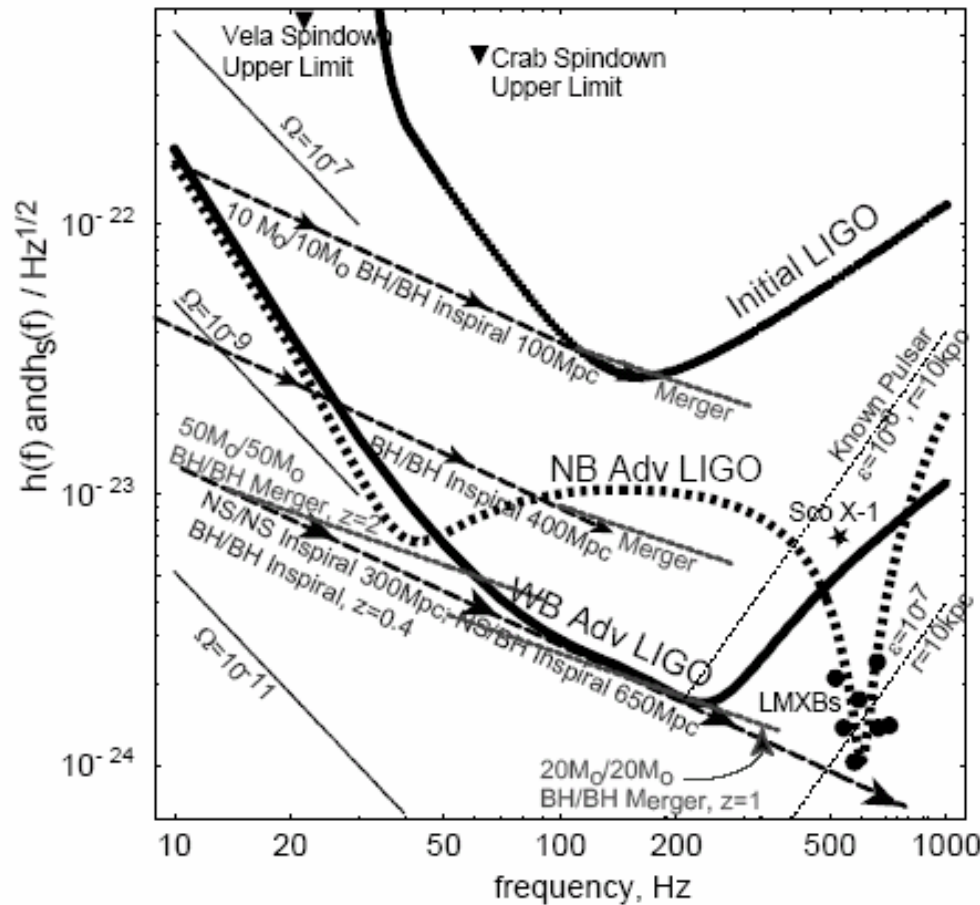

Dashed curve, targeting LMXBs, requires a different SRM reflectivity

More Examples

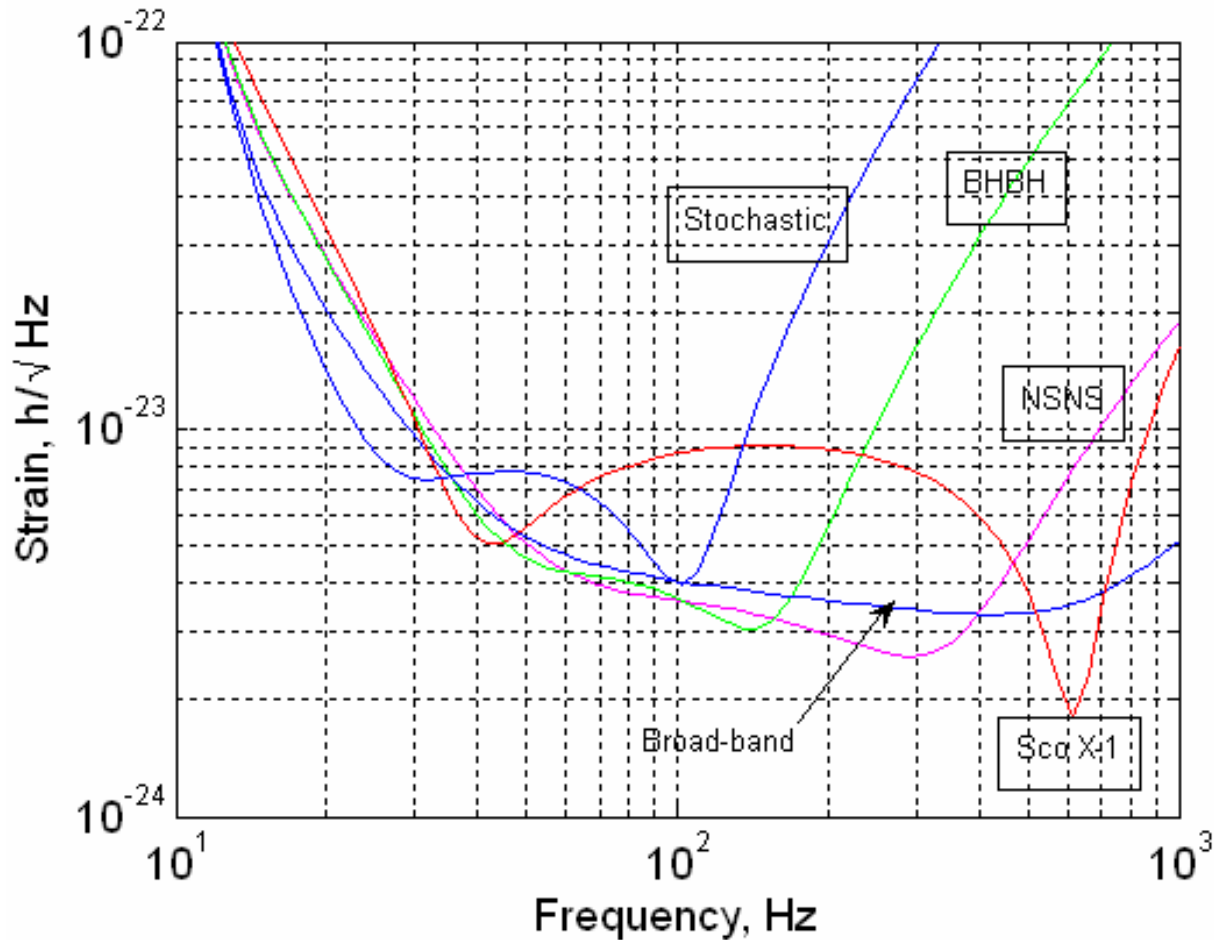

All but ScoX-1 curve use same SRM, but different “tunings” and laser powers

Courtesy D. Shoemaker

Triple or Double Coincidence?

- Probably need triple coincidence in initial AdLIGO operation for same reasons as needed in initial LIGO
- In a mature AdLIGO, double coincidence may be sufficient or another interferometer with similar response across band may emerge
- Switch to a specialized interferometer could be done later
 - » Entails changing signal recycling mirror to obtain different reflectivity or developing a “tunable” signal recycling mirror
 - » Probably entails re-optimization of control system

2-km or 4-km option

- In triple coincidence operation, same arguments should apply as in initial LIGO
- No doubt about it, in a specialized, single-interferometer application the factor of two in length costs a factor of two in sensitivity
- Major facilities can accommodate either choice; some movement of vacuum chambers, minimal fixturing needed
- Cost implications are small (0.2% of AdLIGO budget)

What would I recommend?

- Use H2's length to fullest advantage in initial LIGO to get best results and to document the sensitivity gains/losses with real experience
- Plan to start AdLIGO with three similar bandwidth interferometers in triple coincidence; achievable with H2 at 2 or 4 km; double coincidence can come later
- Analysis groups should debate whether they want a better stochastic limit using H1•H2 (might favor H2 @ 2 km) or to send a single interferometer after LMXB's or inspiral endpoints or some other signal (favors H2 @ 4 km)
- Assess controls aspects of changing frequency response of interferometers. (Does it take a day or a year to change response?)
- Consider variable-reflectivity SRMs or just buying more SRMs