

Template placement for precessing binaries

Ben Owen and Chad Hanna



LSC Meeting at LLO, ASIS session

March 18, 2004

LIGO-G040079-00-Z

Precessing binaries

Spin S and orbital angular momentum L trace cones about J :

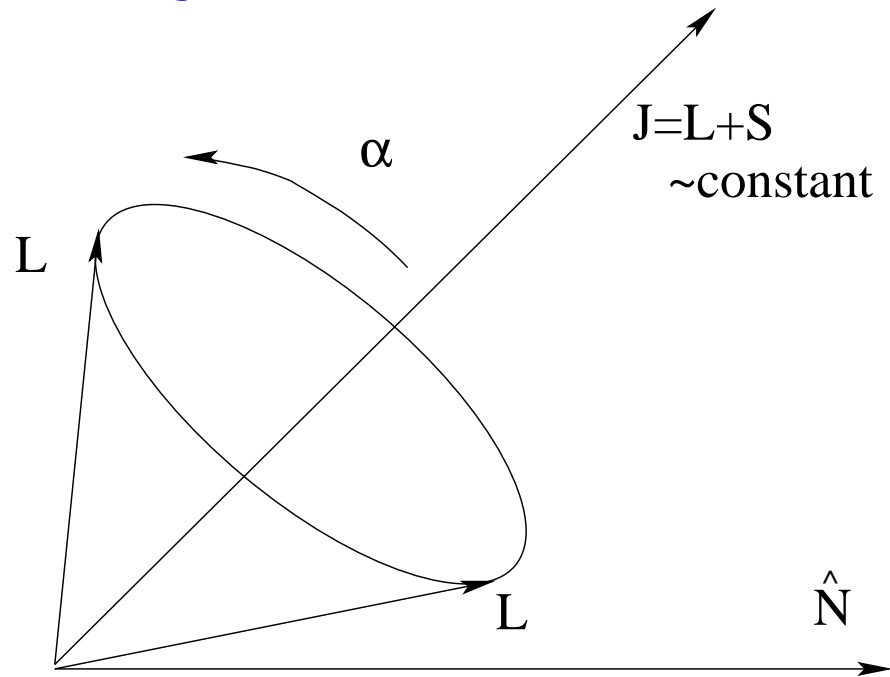

Polarization of signal depends on $\hat{L} \cdot \hat{N} = \text{const.} + \text{const.} \times \cos \alpha$,
varies most for $L \ll S \Rightarrow m_2 \ll m_1$. (Apostolatos *et al.* 1994)

Matched filtering without spin

Sinusoidal signal w/unknown time & phase offsets:

$$h \propto \cos[\psi(t - t_0) + \delta] \text{ (Helstrom 1967)}$$

Max. over phase offset δ by adding power in sine & cosine filters:

$$\rho^2 = (h, \cos \psi)^2 + (h, \sin \psi)^2 = |(h, e^{i\psi})|^2.$$

if $(\sin \psi, \cos \psi) = 0$ (usual inner product).

Maximize over time offset t_0 by hunting for peaks in FFT.

Leaves *intrinsic* parameters (map to m_1, m_2 for binaries without spin) to search over by other means, e.g. metric-based tiling.
(Owen 1996)

Bad news: precession means 9+ parameters in principle.

The \mathcal{F} -statistic

Signal is contraction of source & detector beam-pattern tensors:

$$\begin{aligned} h &= F_+ A_+ \cos \psi + F_\times A_\times \sin \psi \\ &= \sqrt{(F_+ A_+)^2 + (F_\times A_\times)^2} \cos(\psi + \delta) \end{aligned}$$

Amplitude & phase modulation if either tensor changes.

More modulation parameters? Not needed with \mathcal{F} -statistic.

Developed for pulsars (A 's fixed, F 's change) by [Jaranowski *et al.* \(1998\)](#).

Applied to binaries (A 's change, F 's fixed) by [Buonanno *et al.* \(2003\)](#).

Gains full power of matched filtering.

Maximizes quickly over various angles.

Must mean something physically?

How the F-statistic works

Complex modulation in frequency domain:

$$\tilde{h}(f) \rightarrow \tilde{h}(f) [Z_0 + Z_1 \cos \alpha(f) + Z_2 \sin \alpha(f)]$$

Carrier $e^{i\psi}$ gains sidebands $e^{i(\psi \pm \alpha)}$.

Spacing between carrier & sidebands is given by α .

Relative amplitudes depend on $\hat{J} \cdot \hat{N}$ and α .

For strong modulation, carrier & sidebands are orthogonal:

$$\rho^2 = \mathcal{F} = |(h, e^{i\psi})|^2 + |(h, e^{i\psi} e^{i\alpha})|^2 + |(h, e^{i\psi} e^{-i\alpha})|^2$$

adds power in carrier & sidebands, sine & cosine of each.

If they're not orthogonal, you make 'em so with Gram-Schmidt.

But then you get problems. . . [Pan et al. 2004](#)

Technical details

Identify distance w/loss in ρ^2 : provides parameter-space metric.
Strong modulation makes metric simple: (Owen & Vecchio 2004)

$$2g_{ab} = 3(\partial_a\psi, \partial_b\psi) + 2(\partial_a\alpha, \partial_b\alpha) - \text{projections}$$

Block diagonal, expressed in terms of noise power moments if masses written as (ψ_0, ψ_3) and $\alpha = \beta f^{-2/3}$ (good for $m_1 \gg m_2$):

$$J_p \propto \int \frac{df}{f^{p/3} S_h(f)}$$

Not-so-strong modulation:

Still pretty simple, only need sine & cosine moment functions

$$S_p(\beta) = \int \frac{df \sin(\beta f^{-2/3})}{f^{p/3} S_h(f)}, \quad C_p(\beta) = \int \frac{df \cos(\beta f^{-2/3})}{f^{p/3} S_h(f)}$$

These can be stored in an interpolation table (up to $2\beta_{\max}$).

Infinitesimal modulation:

Singular metric 'cos physics is breaking down, so forget it.

2D space: mass parameters

Astrophysical parameter range: $m_1 \in (5, 10)M_\odot$; $m_2 \in (1, 2)M_\odot$

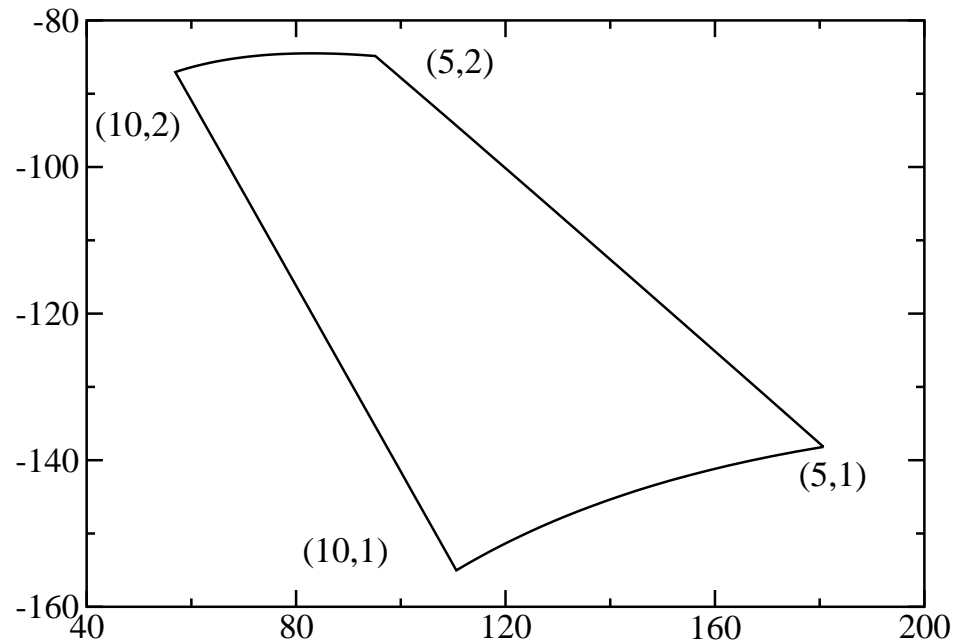

Rectangle in $m_1 m_2$ plane \rightarrow wedge in $\psi_0 \psi_3$ plane.

3D space: Masses and spin

Only large body's spin matters: $S_1/m_1^2 \in (0, 1)$

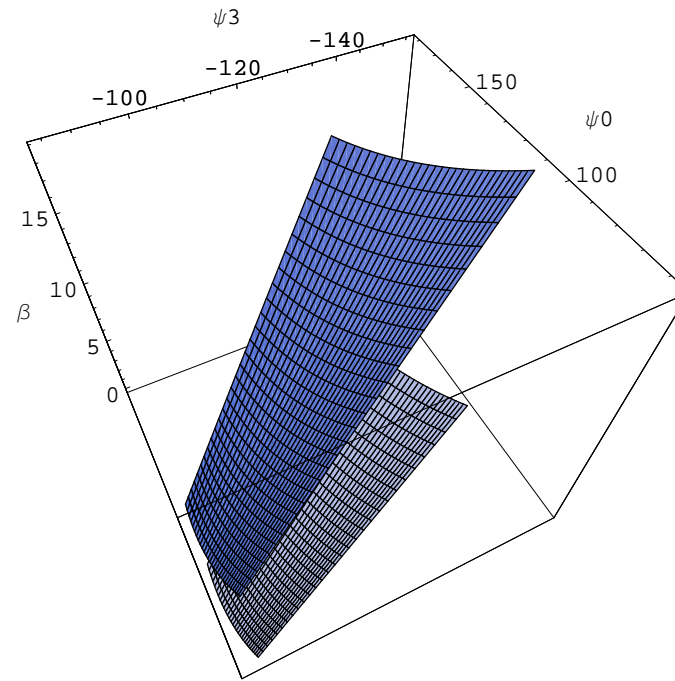

Strongest modulation (highest β_{\max}) is at extreme mass ratio.

Template bank

LIGO-I SRD noise, worst mismatch 100% ($\mu = 1$) for legibility:

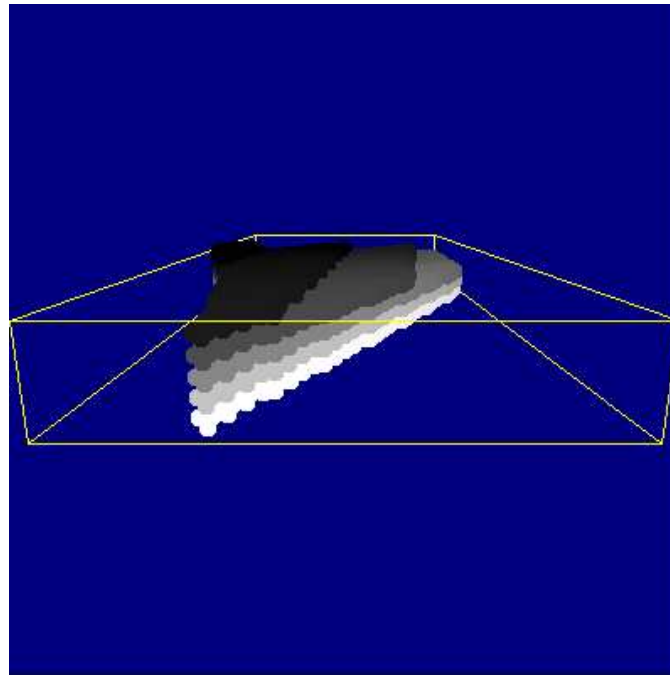

Template count is $250\,000 (0.03/\mu)^{3/2}$.

Conclusions and TBDs

Too many templates for brute force search (limited by χ^2).
Better go hierarchical! (well-suited for it)

Get template placement code into LAL. . . .

Fix up low- β region (number goes down).

Use more efficient lattice. (DONE: 185 000 templates)

Clean up ragged edges (number goes up).

Future: Veto based on coincidence times, relative amplitudes?