

Tunable Power Recycled RSE Michelson for LIGO II

**Malcolm B. Gray, Daniel A. Shaddock, Conor Mow-Lowry
& David E. McClelland**

Dept. of Physics, The

LIGO-G000227-00-D

RSE Michelson Optical Layout

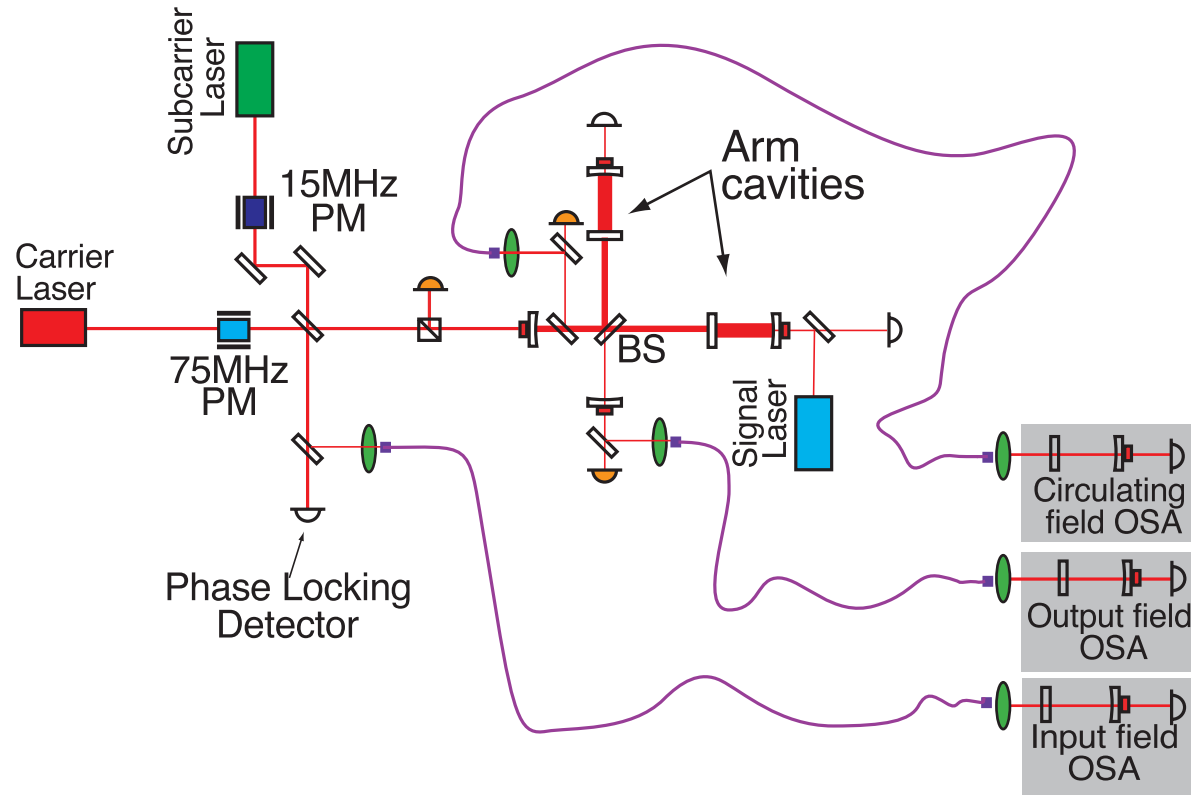

Input Beam Modulation Components

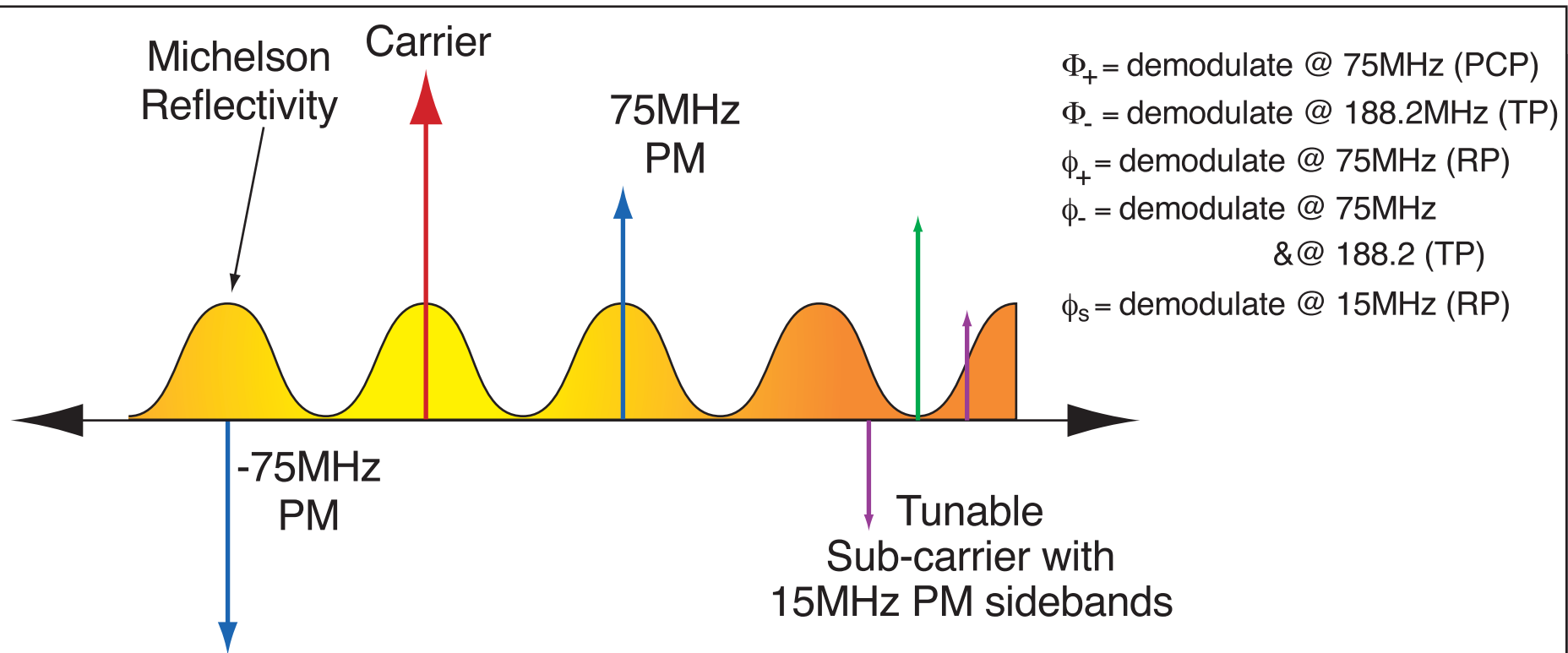

The input beam consists of:

PM@75MHz

Variable offset phase locked subcarrier with PM@15MHz

Single Sideband Production

Our control system for a tunable RSE interferometer requires a subcarrier or single sideband.

This can be achieved by phase locking two lasers with a frequency offset.

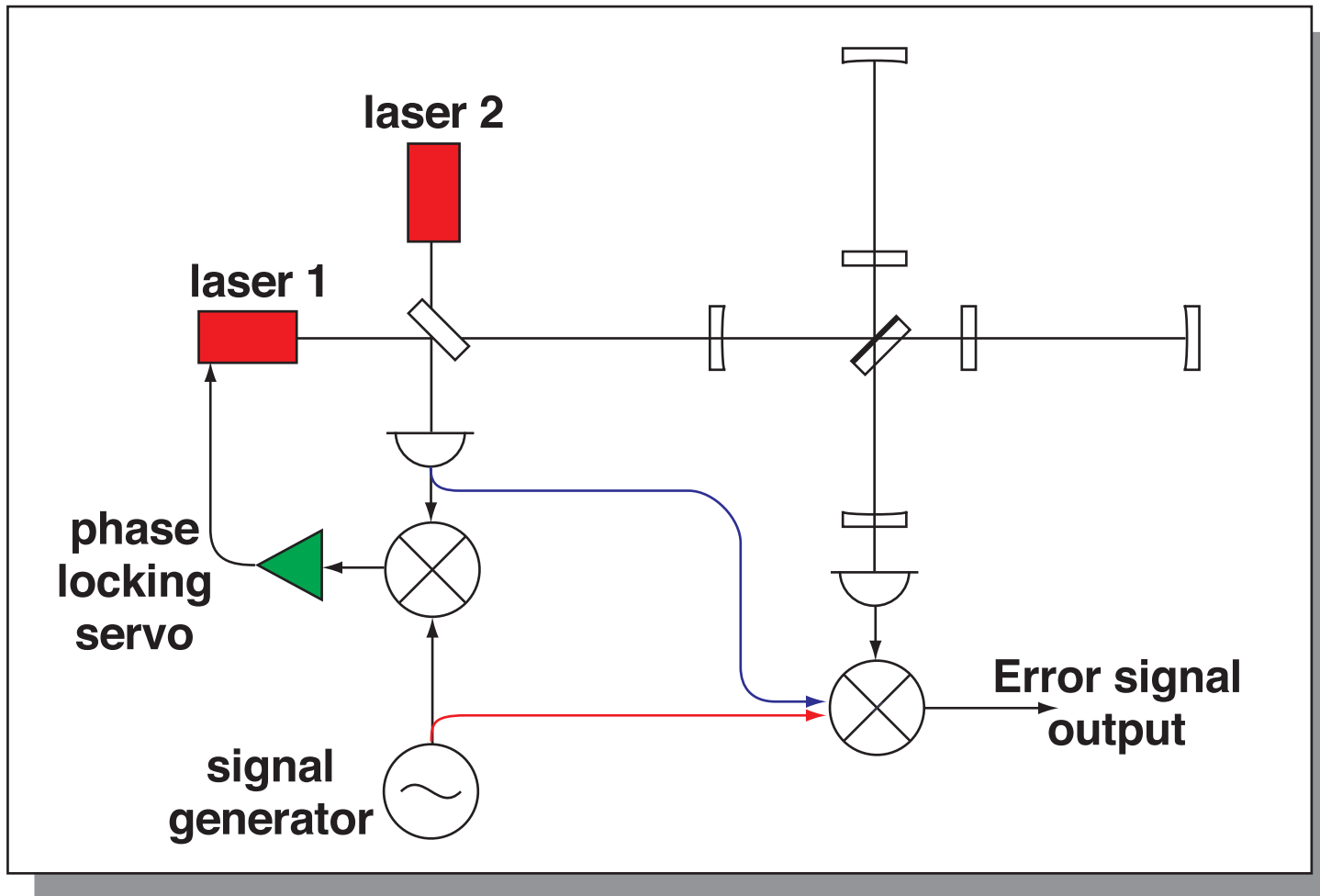

Offset Phase Locking

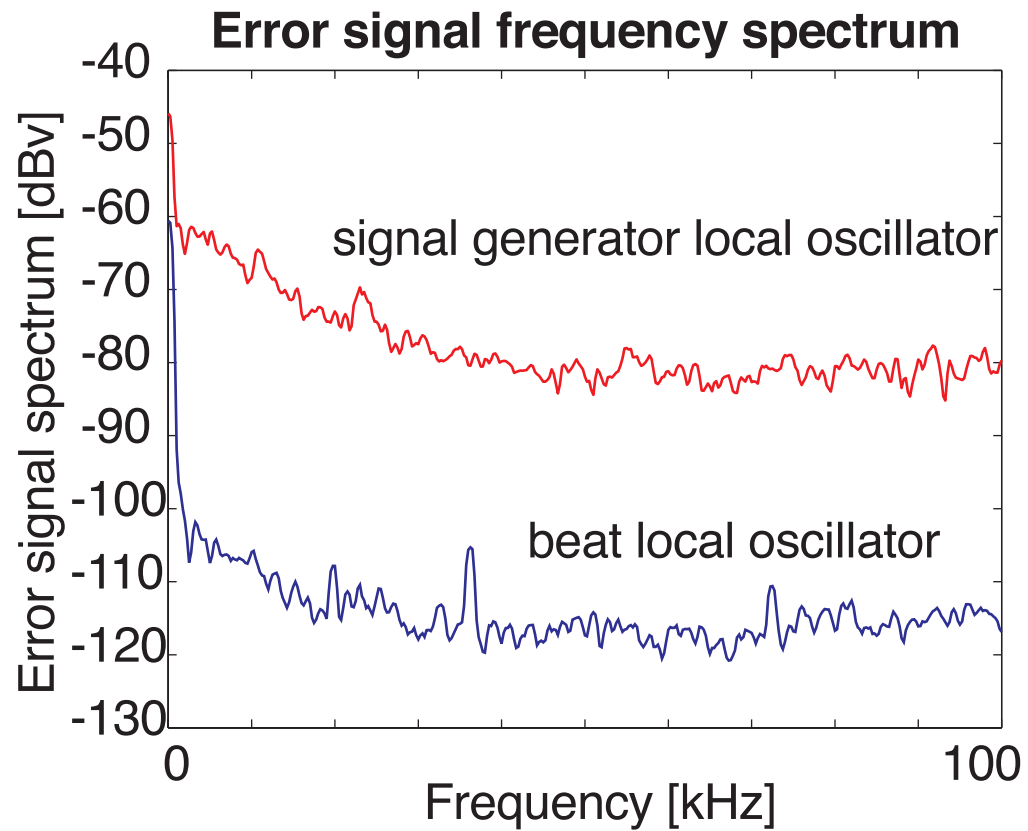
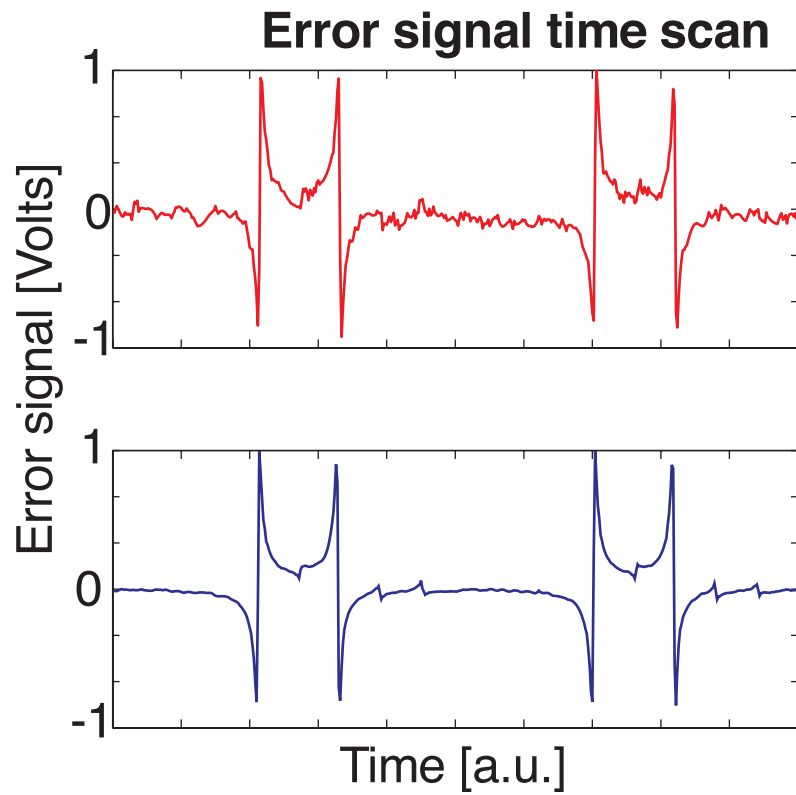

RSE Spectra

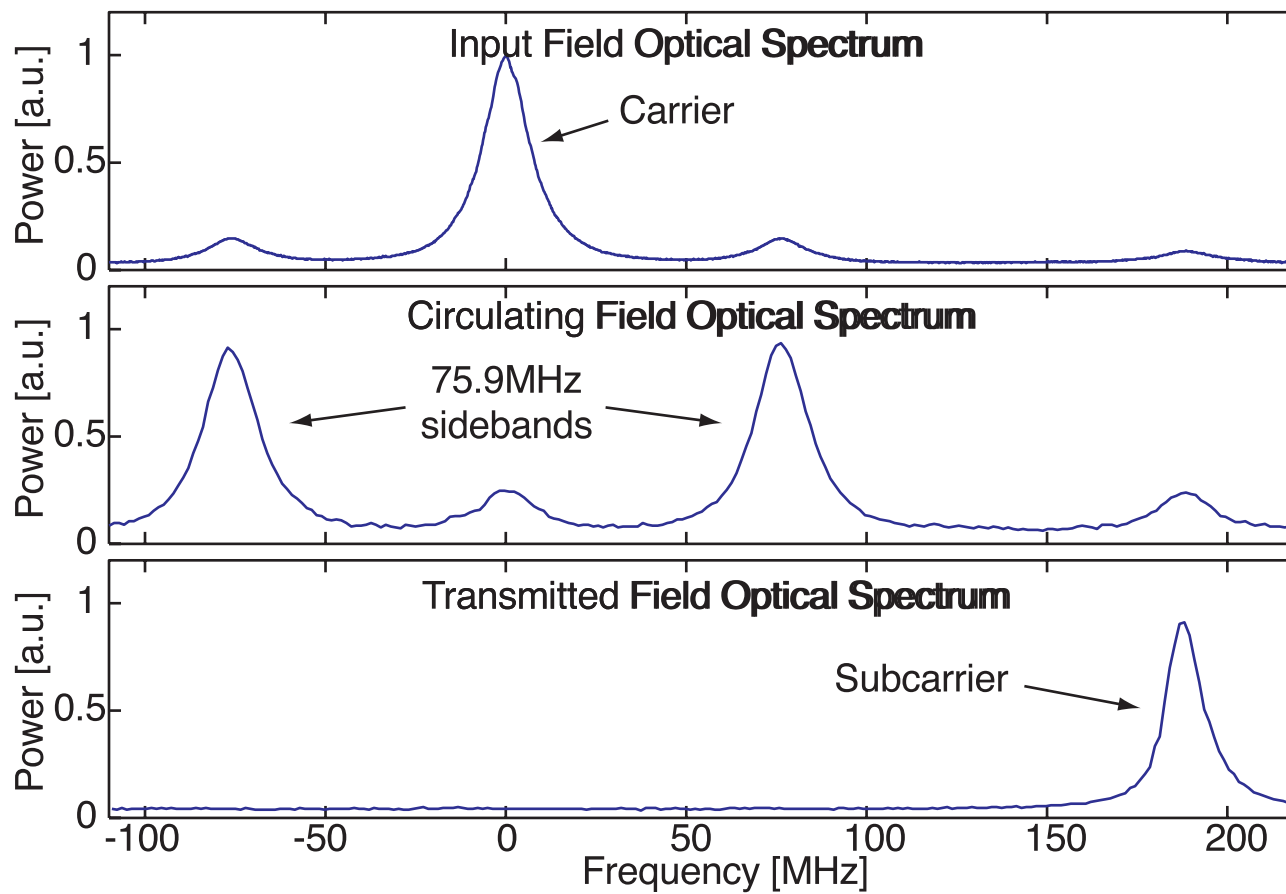

RSE Lock Acquisition

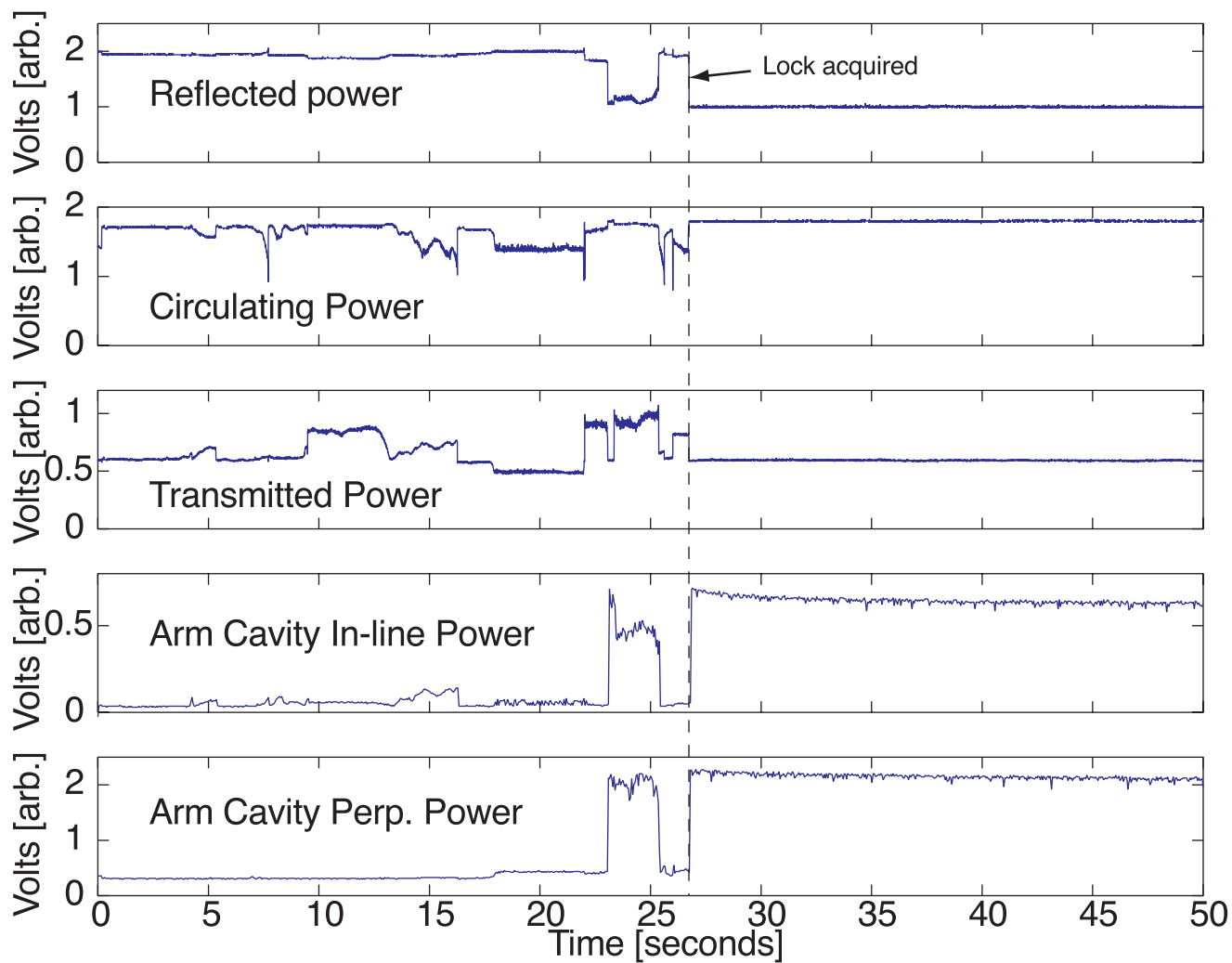

Signal Response for tuned RSE system

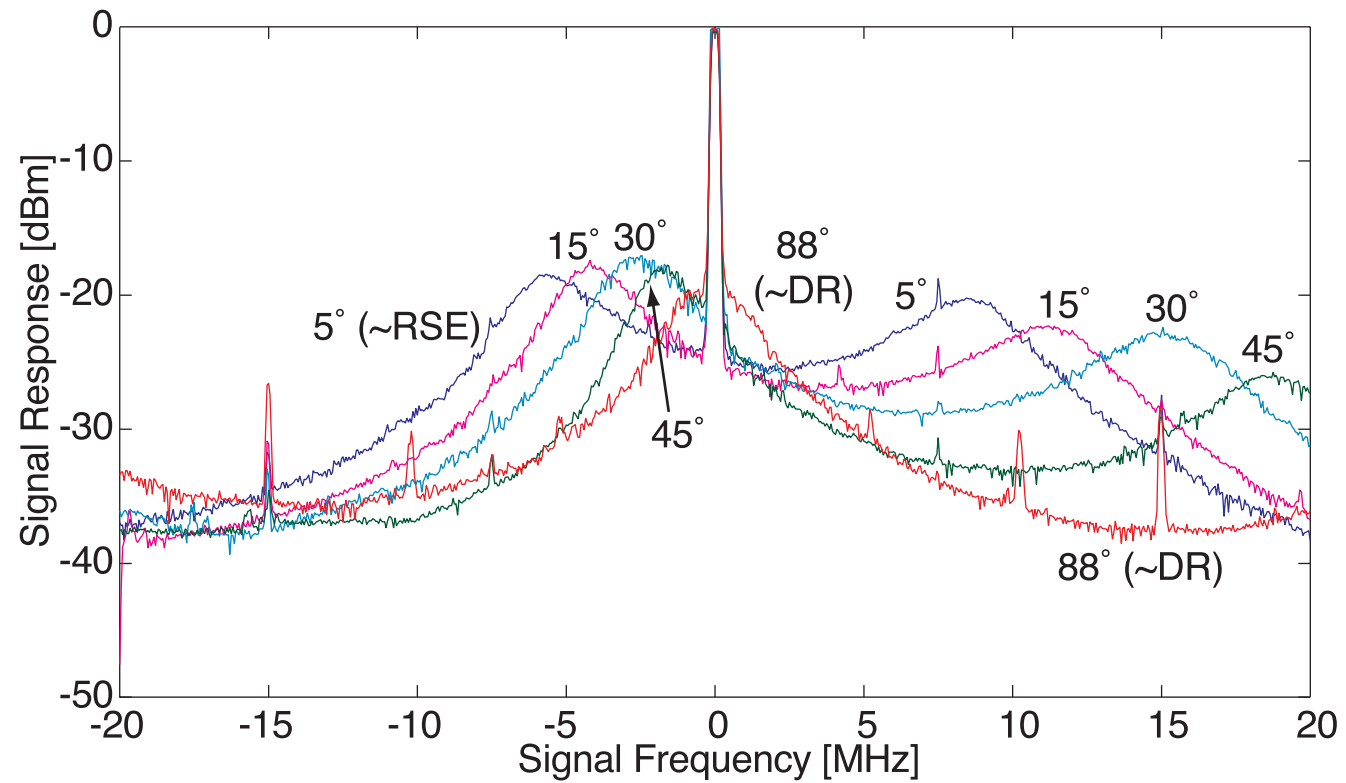

Signal Response for tuned RSE system

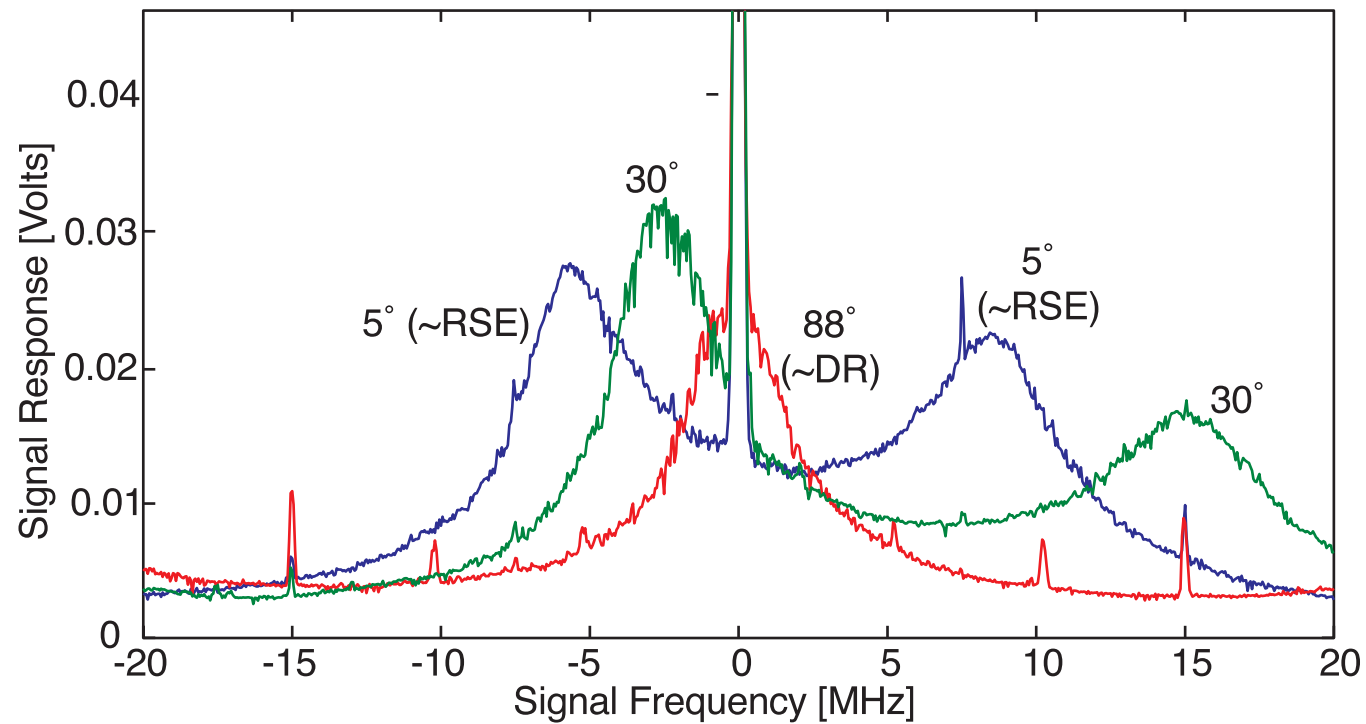

RSE / Dual Recycling Subcarrier tuning

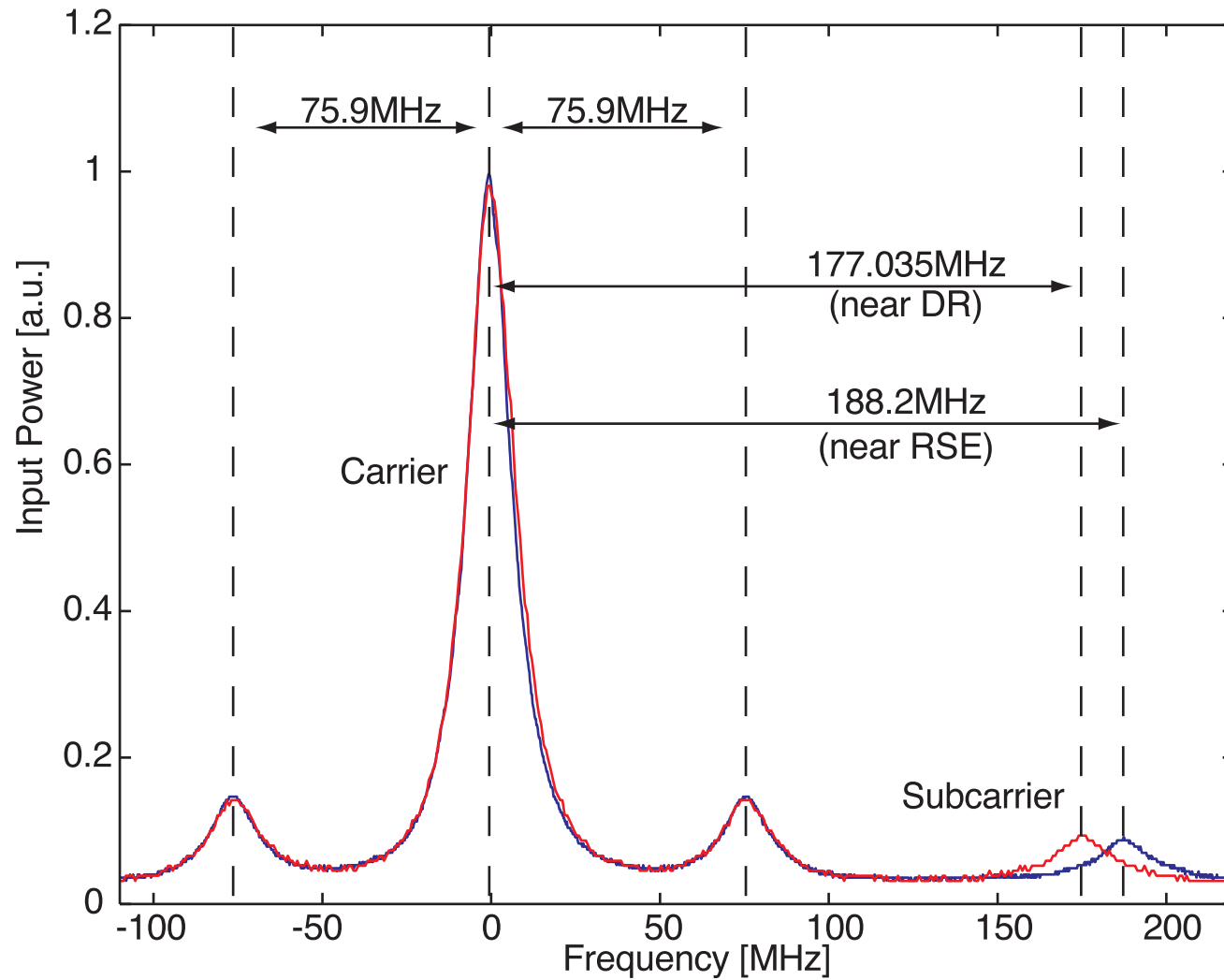

Dynamic tuning of RSE Interferometer signal cavity (from 30 degrees to 15 degrees)

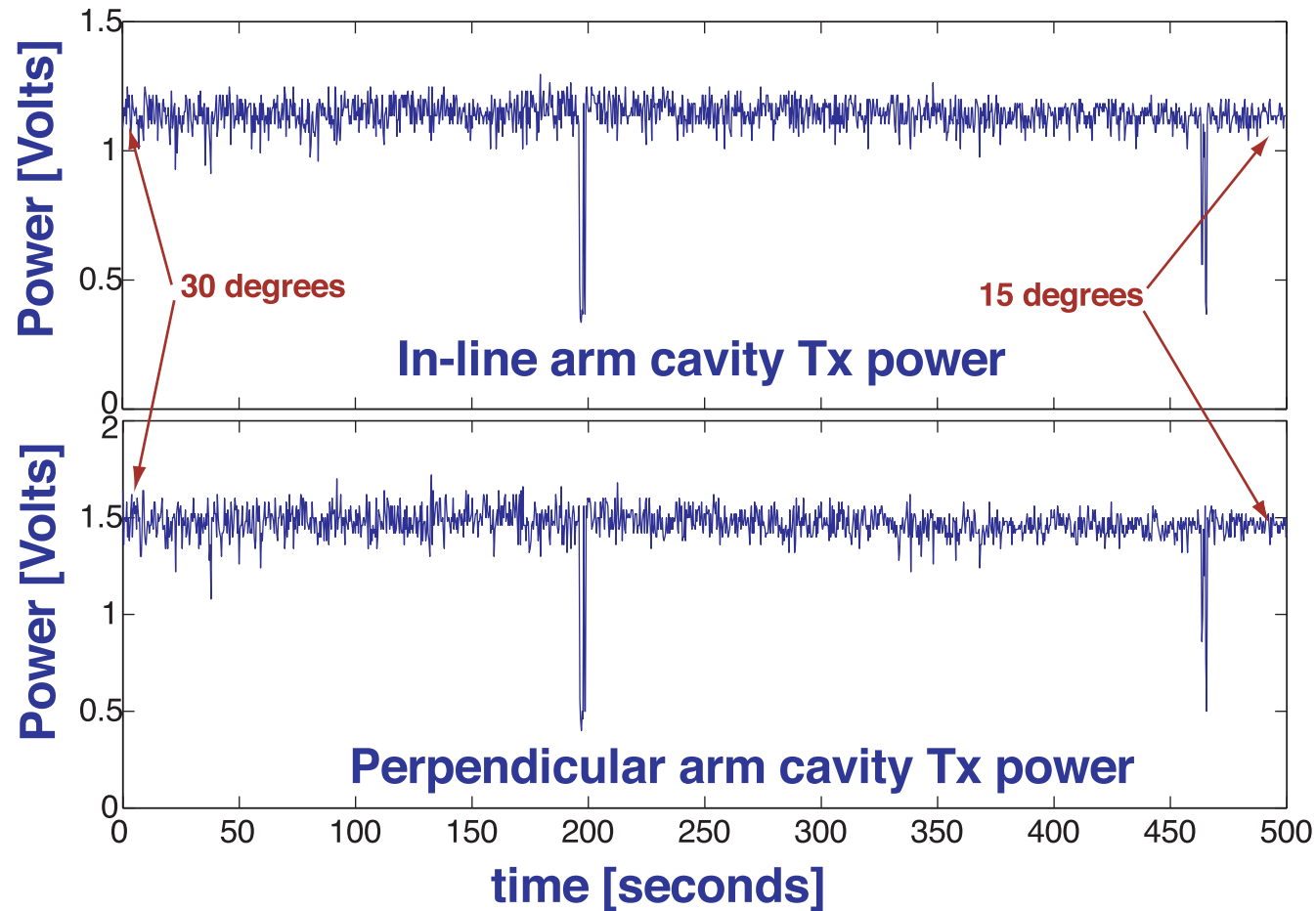

Conclusions

Dynamically tunable RSE/DR system.

Stable locking (>1 hour locking at all lock points).

High degree of error signal orthogonality.

Compatible with long base line interferometer configurations.