



COMPONENT SPECIFICATION

TITLE

Sensor/Actuator Assembly Specification

APPROVALS:	DATE	REV	DCN NO	BY	CHK	DCC	DATE
DRAWN: J. Romie/H. Armandula	8-1-00	A	E010037-00-D	JHR			
CHECKED:		B	E010071-00-D	JHR			
APPROVED:		C	E020575-01-D	JHR			5-15-02
DCC RELEASE:							

1.0 Scope

This specification covers the assembly of the **Sensor/Actuator Assembly, Long, SMD, D000069**, used in the Large Optics Suspension, LOS (see E000033 for top assembly drawing numbers) and the **Sensor/Actuator Assembly, Short, SMD, D000180**, used in the Small Optics Suspension, SOS, D960001. This specification is for the updated sensor/actuator assembly that uses surface mounted devices (SMD). Sensor/actuator head assemblies are commonly called osems.

2.0 Parts Lists

See parts lists of the following top assemblies:
D000069 Sensor/Actuator Assembly, Long, SMD
D000180 Sensor/Actuator Assembly, Short, SMD

3.0 Fabrication of Heads

The head drawings detail the dimensional requirements for the heads along with the surface finish. They also cover the conductive coating requirement and the laser marking requirement. The following paragraphs of the specification cover those three processes.

3.1 Head Part Numbers

D000065 Sensor/Actuator Head, Long, SMD, Alumina
D000067 Sensor/Actuator Head, Short, SMD, Alumina

3.2 Fabrication Specifications

The head drawings detail the dimensional requirements for the heads along with the surface finish. They also cover the conductive coating requirement and the laser marking requirement. This paragraph of the specification covers the fabrication of the head alone along with the surface finish.

The parts need to be fabricated in a clean environment. Raw material or work-in-progress must be protected from the shop atmosphere when not being handled or worked on by plastic sheets or similar protective covers. Polyethylene plastic sheet is acceptable. All machining fluids (if applicable) shall be water soluble and free of sulfur, chlorine and silicone.

After firing, the parts will be checked for iron and chromium contamination. Parts showing contamination will be rejected. A 100% dye penetrant test will be performed to determine if fired parts exhibit cracks or porosity



COMPONENT SPECIFICATION

TITLE

Sensor/Actuator Assembly

due to a faulty firing process. Water soluble dye penetrant will be used. Parts with cracks or porosity shall be rejected. The vendor may consider re-firing for porosity problems but this is not recommended.

The surface finish of 16 or better on all outer diameter surfaces includes the coil groove. That stringent surface finish is not needed on the inner diameter of the parts. The front surface, defined by datum A on both parts, should also comply with the 16 rms surface finish requirement. This surface finish will require extra machining steps and potential vendors should be made aware of this requirement during the RFQ process. Fired alumina generally has a surface finish of about 32 rms surface finish so polishing in the form of centerless grinding and OD diamond honing, if required. If a non-water soluble honing oil is used, extra care will be taken to remove this oil.

The parts will be cleaned in an ultrasonic tank with hot detergent and then rinsed thoroughly with DI water. This step should remove any oil, wax, dye and general handling marks. An inspection of the parts after cleaning will be performed to assure the cleanliness of the parts.

3.3 Head Fabrication Inspection

When the heads, D000065 and D000067, come back from the vendor, inspect the parts for dimensional acceptance. Check that the surface finish complies with the 16 microinch rms callout. Good surface finish is vital to a successful plating operation. Check that the edges and corners have been radiused to .02/.01, which is, again, important for plating adhesion. Check the integrity of the #4-40 threads. Reject parts if these requirements are not met.

3.4 Metalization

Coat OD and front face (as defined by datum A) of heads with conductive material that complies with the surface resistivity specification of note 4 on the drawing. Datum B on the drawings will be masked. It is preferable that the ID of the parts not be coated. Coating shall be wear resistant and exhibit low friction with respect to the 304 stainless mounting brackets. The coating will not chip, crack or flake. The coating shall be non-magnetic.

3.5 Metalization Inspection

There are two resistance tests of the metalization. They will be measured with a multimeter or megaohm meter. The first measurement, called the front face point-to-point measurement, will be made placing one probe on the front face and the other probe on the front face about 1cm away. The second measurement, the front face to body measurement, will be made placing one probe on the front face and the other probe on the OD near datum B. Document these values in the form in Appendix 9, Sensor/Actuator Test Data under "Pre". The resistances shall be within the specified range. Any defects in the coating shall not be allowed if the coating flakes off when abraded with a straight edge razor or when cellophane tape is applied and then removed.

3.6 Laser Marking

Part and serial number identification will be accomplished by laser marking the parts. The laser marking specification is defined in note 5 of both drawings. As an alternative, parts may be marked with a diamond burr tipped Dremel-like tool. Marking will not add any contamination to the parts.



COMPONENT SPECIFICATION

TITLE

Sensor/Actuator Assembly

3.7 Laser Marking Inspection

Inspect the laser marking. Be sure that the identification is legible and that the parts are clean.

4.0 Assembly of Magnet Coil

This part of the specification covers the coil winding and the first cleaning and baking procedure for the sensor/actuator assemblies.

4.1 Sensor/Actuator Assembly Part Numbers

D000069 Sensor/Actuator Assembly, Long, SMD

D000180 Sensor/Actuator Assembly, Short, SMD

4.1 Coil Winding

Using the Kapton wire called out on the drawings, thread the end of the wire down through the hole near the coil groove and out the back of the head. Wind the wire clockwise on the head 400 turns. Take care to align the wire in the coil groove so that the wire is flush or inside the OD of the head. Thread the end of the coil down through the same hole to the inside of the head and bring the wire out the back. Leave approx. 6" at the beginning of the coil and 6" at the end of the coil, measured from the back of the head, to allow for dressing of the wires. For identification purposes, tie a knot at the end of the "finish" coil wire (not the "start" wire.) Secure the wires to the head with a rubber band or equivalent so that the coils will not unwind during inspection and shipment.

4.2 Coil Winding Inspection

Inspect the coils. Check that the wires are uniform and flush or inside the OD of the heads. Perform a short test and document. Perform a visual inspection to make sure coil wire is not cut, abraded or in a position to be cut or abraded.

4.3 Test and Strip Wires

Strip the ends of the coil wire using the magnet wire stripper made by The Eraser Company, model no. DCF1/Item # AR4501. Put a loose knot in the "finish" end, to replace the one cut off. Using a multimeter, clamp a probe to each wire and check the resistance and inductance. Document this data using the head serial numbers, on the traveler.

4.4 Coil Wire Strain Relief

Mix Ceramabond per instructions on containers. Apply a small dab of Ceramabond to wires at the hole near the coil groove. Apply the adhesive at the top of the hole and the bottom of the hole, in the inside of the head. This will secure the coil wires and assure that they do not move or unwind during handling and shipment. Then position the wires such that they fall inside the groove on the back surface of the head (on Datum B). Twist the wires 3-4 times inside the head. Pull them taut inside the head. Apply a small dab of adhesive to secure these wires in the groove. Take care to make sure the Ceramabond is flush to Datum B so as not to bother the mounting of the brackets. Secure the wires to the OD of the heads. Air dry Ceramabond at room temperature for 1 - 4 hours and then air bake at 200 deg. F for 2 hours.



COMPONENT SPECIFICATION

TITLE

Sensor/Actuator Assembly

4.5 Coil Hot Bake

Clean per LIGO-E960022. See traveler for details.

5.0 Circuit Board Assembly

This part of the specification covers the fabrication and assembly of the circuit boards that are mounted in the sensor/actuator heads. There are two part numbers, one for board with the LED and one for the board with the photodiode. There are different length boards depending on which head they will be assembled into. This part of the specification also covers the scribing of the air vent for the photodiode optical filter, fabrication of the filter spring clip, mounting of the clip and installation of the optical filter.

5.1 Circuit Board Part Numbers

D000243 Circuit Board Assembly, LED

D000244 Circuit Board Assembly, Photodiode

D000069 long sensor/actuator assembly uses the D000243 LED circuit board assembly with D000204 LED long circuit board and the D000244 photodiode circuit board assembly with D000205 photodiode long circuit board.

D000180 short sensor/actuator assembly uses the D000243 LED circuit board assembly with D000194 LED short circuit board and the D000244 photodiode circuit board assembly with the D000195 photodiode short circuit board.

5.2 Circuit Board Cleaning and Soldering

Clean boards by soaking in isopropyl alcohol for 10 minutes. Use latex gloves while handling these parts from this point in the process onward. Scrub the boards with an acid brush. Do the same with the LED and photodiode. The photodiode boards are identified by "P" near the hole. That will be the only way that assembly personnel will be able to identify the boards after soldering as the components look alike.

Clamp a board into a PC vice. Position a device on the solder pads. Take care to center the lens of the device in the center of the hole in the board. Apply pressure to the back of the device, in the form of a tweezers, for example, to reduce the amount of solder under the pads. Flux and solder the device to the board. Solder under the pads will distort the perpendicularity of the device relative to the board and therefore distort its performance. Use the pressure on the device during the soldering operation to maintain perpendicularity of the device relative to the edges of the board.

Strip one end of two pieces of 3.00" +/- .25" long Kapton wire using The Eraser Company's magnet wire stripper. Flux and solder the wires to the board. Strip only enough of the Kapton so that after soldering it to the board, no copper wire is exposed. This is critical as shorting may occur if wire is exposed. Use a minimal amount of solder on this joint as the parts won't fit together with a large lump of solder.

Soak the assembled boards in isopropyl alcohol for 10 minutes. Carefully brush the boards clean. This step should remove most of the flux. Use another beaker of clean isopropyl alcohol for a final cleaning.



COMPONENT SPECIFICATION

TITLE

Sensor/Actuator Assembly

If shipping of the boards is required at any point, wrap them carefully in UHV foil, then wrap in a CP Stat bag. Mark the bags to indicate the board assembly part number.

5.3 Circuit Board Groove

Using a Dremel tool or diamond tip scribe, mark a line or groove .25" long from the hole in the photodiode boards towards the soldered wires. This groove is scribed into the side opposite the device. It is only needed on the photodiode boards, D000205 and D000195 (with the "P" marked on the opposite side.) This line may be very narrow and shallow as it is only used to allow air to escape from underneath the optical filter that is soldered on later. This operation may be performed prior to the processes described in 5.2 above.

5.4 Fabrication of Filter Spring Clip

The filter spring clip is a U shaped spring that holds the photodiode optical filter, D000209, onto the photodiode circuit board assembly, D000244. It is made from beryllium copper spring stock. The manufacturer is Tech-Etch Inc., 45 Aldrin Road, Plymouth, MA 02360, (508) 747-0300. Their web page is <http://www.techetch.com>. The spring stock part number is 60R-16-02 and comes 16" long. Clean the spring stock in a warm Liquinox solution and then rinse with DI water. Take care to rinse thoroughly with DI water. Ultrasonic clean in acetone for 5 minutes and then ultrasonic clean in methanol for 5 minutes.

Procure Photo-Etch Shears from MicroMark, 340 Snyder Avenue, Berkeley Heights, NJ 07922, (800) 225-1066. Their web page is <http://www.micromark.com>. The Photo-Etch Shears part number is 81308. Also procure their Smooth Jaw Clips, part number 14532, which will be used later. Use the shears to cut off 4 fingers at a time. Then, for each 4 finger section, use your fingers to bend the 2 middle fingers over at a 90 deg angle. Snap off the two middle fingers.





COMPONENT SPECIFICATION

TITLE

Sensor/Actuator Assembly



5.5 Assembly of the Spring Clip to the Board

Mount a circuit board in a PC vice. Use clean tweezers to pick up the spring clip. Line up the spring clip with the solder pad. Position the spring clip so the “spoon” pressure on the fingers will apply pressure to and support the photodiode optical filter. Solder the clip to the board. Use the Smooth Jaw Clips to hold the spring clips to the board. Spray board with Deflux solution. Ultrasonic clean in Liquinox for 10 minutes. Rinse in DI water at least 3 times, changing rinse water every time. Ultrasonic clean in methanol for 10 minutes.

5.6 Cut Wires to Length

Cut the wires soldered to the boards to the dimensions shown below. Strip ends of the wires back by .1” using the magnet wire stripper listed above.



COMPONENT SPECIFICATION

TITLE

Sensor/Actuator Assembly

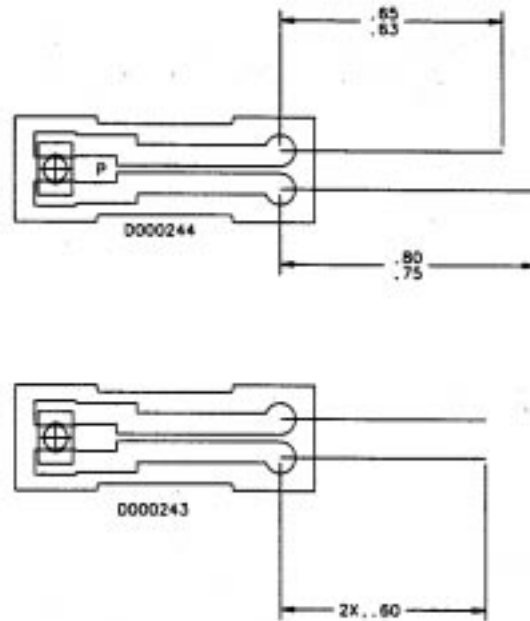

5.7 Screen LEDs

Screen the LED boards, D000243, using a fixture and a test photodiode board. Use an IR camera to view the LED output relative to the hole in the circuit board. Set aside the boards that have an obvious offset between the LED output and the hole and the ones whose LED axis is obviously skewed from the hole axis.

6.0 Sensor/Actuator Assembly

This part of the specification covers the fabrication of the retaining clip and the assembly of the circuit boards into the sensor/actuator head. It covers the testing of the assemblies. It also covers the fabrication of the pin plates and the photodiode optical filters. Sensor/actuator pigtail and PAM screw assembly follow in Section 7.0. From this point in the specification onward, all assembly steps must take place in a clean room, with personnel dressed in clean room garb and wearing approved gloves for handling UHV components.

6.1 Fabrication of Retaining Clip

The retaining clip is used to separate the two circuit boards in the sensor/actuator head. It is made from phosphor bronze spring stock. The stock material is .004" thick x 1" wide and 85' long. It can be bought from McMaster Carr, p/n 90545K11, spring tempered phosphor bronze coil.

Cut a strip of material, .25" x 3/4". Using smooth nose (not knurled) needle nose pliers, curl the ends of the strip inward. Curl the ends inward so that the outside dimension is .25"



COMPONENT SPECIFICATION

TITLE

Sensor/Actuator Assembly

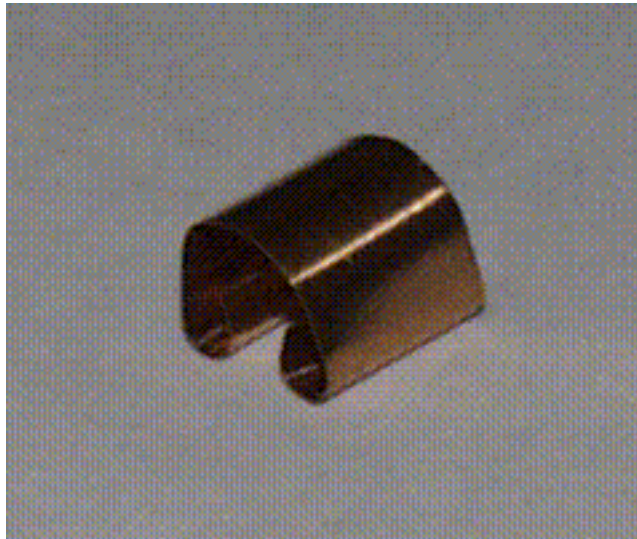

6.2 Mount Circuit Boards

Insert circuit boards into the sensor/actuator heads using a Teflon positioning device. Insert retaining clip to separate and support the boards. Two clips should be used for the long heads and one for the short heads. The retaining clip may be positioned so that it sits on top of the flat part of the filter spring clip. Try to align the boards well such that the boards are parallel to each other. Be sure the boards are positioned relative to the sensor/actuator head correctly, per the drawing. Use the #4-40 threads in the back for alignment. A number of heads were made incorrectly - the coil wire through-hole and the wire strain relief groove in the rear are rotated relative to the #4-40 screws threads in the rear of the head. Again, use the #4-40 threads for alignment rather than the through-hole. Put the head on a clean table, face down, and push the boards so as to be flush to the front surface.



COMPONENT SPECIFICATION

TITLE

Sensor/Actuator Assembly

6.3 Positioning the circuit boards with the test box

Use an IR video camera or equivalent to check that the LED works and that its light is pointed towards the photodiode. Twist knob on the test box to provide #3 readout. Test box instructions are detailed in LIGO-E010070. Adjust position of boards relative to each other to give a maximum value for the photodiode current. Only adjusts the boards fore and aft in the sensor/actuator head, do not tilt relative to each other. If boards cannot be positioned to keep the photodiode current above 90 μ A, switch out boards and try again. Follow the tests outlined in LIGO-E010070, section 3.1

6.4 Apply Ceramabond to boards

Procure Aremco Ceramabond. Follow the directions and prepare some Ceramabond. Using a dental tool apply Ceramabond to edges of circuit boards as shown on the top assembly drawings. While applying adhesive, keep wires attached to test box, showing the photodiode current, switch position #3, to make sure the circuit boards do not rotate relative to each other. Ceramabond will harden quickly so work quickly. Unhook wires from test box. Air dry at room temperature for 1 - 4 hours and then air bake at 200 deg. F for 2 hours.

6.5 Perform Pre-bake Testing

After the heads are cooled, perform a pre-bake test per E010070, section 3.2.

6.6 Pin Plate Assembly

The pins for the Sensor/Actuator Pin Plates, D970073, come from another connector, an Augat DIP socket, p/n 508-AG10D. They may be bought separately but generally have a substantial lead time (i.e. 21 weeks) and cost more. If they are bought with the DIP socket, they must be removed from the connector. It is best to carefully heat up the connector with a heat gun and pop out the pins. Soak the pins with methylene chloride and then ultrasonically clean with methylene chloride. Look under a microscope to make sure that any black residue from the connector is gone. Load up 6 pins into one pin plate with hand pressure. Use this pin plate as a stamper. Load up 6 more pins onto the ends of the stamper's pins. Use an arbor press to press the pins (with the stamper) into another pin plate.

6.7 Fabrication of the Photodiode Optical Filter

As the Photodiode Optical Filters, D000209, are fragile care must be taken while fabricating them. Procure the substrate material and then have it coated, per the information on the drawing. The coated glass then needs to be cut or diced. A silicon wafer fabrication facility can do this best. They should also be able to clean the parts afterward. The parts should be cleaned with Opticlean to remove any wax used to hold them down during cutting. They should then be ultrasonically cleaned with acetone to remove the Opticlean. Then, they should be ultrasonically cleaned in warm isopropyl alcohol. The cleaning operations should utilize stainless mesh catch basins to protect the filters from damage. Pack the filters for shipping in a single layer, separated by Kodak paper, with foam on either side, in a plastic box.

6.8 Solder Pin Plate to Wires

Insert a thick spacer between the end of the head and the pin plate for this operation. The spacer should be .20" thick and .250" OD and .125" ID. Attach the pin plates to the head with one #4-40 screw. Solder wires to pins



COMPONENT SPECIFICATION

TITLE

Sensor/Actuator Assembly

on the pin plates per the top assembly drawings. Use flux remover on the joints to clean the solder joints. Use care to keep the flux remover away from the rest of the sensor/actuator head assembly. Remove the thick spacers. Insert the PAM brackets, D990479, into the long heads, taking care not to snag a wire. Remember that PAM screws and brackets are only used on the back of the large optics, not the side. They are not used on the small sensor/actuator assemblies. Check that there is no difficulty screwing the vented #4-40 screws into the alumina heads. If there is difficulty assembling the #4-40 screws into the alumina heads, the screws may be etched and then citric acid re-passivated. The thread OD should be .103/.106". Be sure to clean and bake these screws separately.

6.9 Assemble Hardware

Assemble the heads with Teflon washers. Insert the osem aluminum spacers, D000322, into the small sensor/actuator assemblies. Use two more #4-40 screws to hold the assemblies together.

6.10 Final Cleaning and Bake

Clean per LIGO E960022. See traveler for details.

6.11 Final Assembly

Slip the photodiode optical filter under the "spoons" of the filter spring clip. The filter's front edge will not be flush with the front edge of the head. The front edge of the filter should extend about 1-2mm past the hole in the photodiode circuit board. Assemble the cleaned and baked pigtailed, D990675 and D990676, onto the head after the final bake of the head in the orientation shown on the top assembly drawings.

6.12 Retest

Retest the assembled sensor/actuator assemblies, per E010070, section 3.2.

7.0 Pigtail and PAM Screw Assembly Fabrication

This part of the specification covers the fabrication and assembly instructions for the pigtailed and PAM screw assembly.

7.1 Part Numbers

D990675 Sensor/Actuator Pigtail, Long
D990676 Sensor/Actuator Pigtail, Short
D000255 PAM Screw Assembly
D990479 PAM Bracket, Aluminum

7.2 Pigtail Fabrication

Press the "D" pins into the Pigtail Rectangular Plate Detail, Item 2, D990675 and D990676, such that the solder will face towards the angled holes, as shown. Cut 6 pieces of wire to length plus 2 inches. Insert 2 wires into each angled hole. Strip and tin each wire. Trim the tinned portion to about .03". Neatly fill the "D" pin solder cups with solder. One by one, melt the solder and insert the correct wire into the solder at a right angle to the pin at the lowest point in the cup, as shown. Use a minimum amount of solder in all soldering operations. The wires should be pulled taut to remove any unwanted slack.



COMPONENT SPECIFICATION

TITLE

Sensor/Actuator Assembly

Twist each pair of wires about 5 twists per inch. Loosely braid the three pairs to the end. Don't allow the pairs to untwist while braiding.

Remove the DIP pins from the connector as described in section 6.6. Press the pins into the Pigtail Pin Plate Detail, Item 1, D990675 and D990676, per drawing using method described in section 6.6. Test the continuity of each pair to determine the origin in the rectangular plate. The pair that originates at pins 1&2 in the rectangular plate should be inserted into the strain relief hole that goes into pins 1&2 in the round plate, as shown. Repeat for the other pairs, as shown.

Cut each wire to the appropriate length for the pin to which it belongs. Strip each wire to about .12" and tin the bare wire. This tinned portion should encircle the appropriate pin and be soldered in place. Follow a neat wire dress procedure. Clean off solder flux.

7.3 PAM Screw Assembly

The magnets and the PAM screws, should be cleaned per LIGO Vacuum Compatibility, Cleaning Methods and Qualification Procedures, LIGO-E960022.

Measure the magnet strength of approximately 12 magnets using an F. W. Bell Model 9200 Portable Gaussmeter with a Gaussmeter Probe, P/N HTB92-0608 and the Magnet Strength Fixture, P/N D970169 for magnet testing. Collect a set of magnets that have comparable strengths to within +/- 5% for use as PAM magnets. Preheat airbake oven to 100 C. Sand and de-grit magnets: Lightly sand both ends of each magnet with 800 grit sandpaper. Place the magnets a few at a time on a clean razor blade and blow off grit using the CO₂ blaster. Put the magnets upside down on a fresh razor blade and blow of more grit. Repeat a few times until all grit is gone. Using a microscope, examine the sanded magnet ends to make sure that all grit has been removed. Clean the magnets in an ultrasonic agitator with acetone.

Prepare epoxy: Mix the two epoxy components of a Vac Seal "bipax" together thoroughly (approximately 1 minutes). Dispense from the middle of the container into a boat made from clean UHV aluminum foil. Degas epoxy: Place the boat containing the epoxy into a small vacuum chamber and evacuate to usual backing pump level of vacuum for 2 minutes. Stand the PAM screws up in a small beaker or the like with the tips up.

On a razor blade, lay out the 12 PAM magnets with the S poles down. The polarity of a magnet can be easily determined by rolling it in a clean glass dish and noting which end rotates to face north. Be sure to hold the dish well away from any metal furniture, especially any optical table. Epoxy PAM screws/magnet: Dip the end of the length of cleaned copper wire in epoxy and withdraw it, leaving a tiny amount of epoxy on the wire. Apply the epoxy on the wire to the upper end of a magnet on the razor blade. The optimum adhesive thickness is .003" [.08mm] or a volume of $3.9 \times 10^{-6} \text{ in}^3$ [.06mm³]. Initially the epoxy should only cover a diameter of about .02" [.5mm] with a height of .01" [.3mm]. Once the correct amount has been applied, smear it evenly over the whole end of the magnet. Using a sturdy pair of non-magnetic tweezers, pick up the magnet, turn it upside down and insert it carefully into the counterbore in the end of a PAM screw, making sure not to get adhesive on the screw.



CALIFORNIA INSTITUTE OF TECHNOLOGY
MASSACHUSETTS INSTITUTE OF TECHNOLOGY

E000388-B-D

DRWG NO.

REV. GID

COMPONENT SPECIFICATION

SHEET 12 OF 14

CONTINUATION SHEET

TITLE

Sensor/Actuator Assembly

Press the magnet down into the counterbore. Check to make sure the magnet's axis is colinear to the axis of the screw. Take care to center the magnet in the counterbore of the screw. Put the PAM screw/magnet assembly into the airbake oven and cure for 2 hours at 100 C.



COMPONENT SPECIFICATION

TITLE

Sensor/Actuator Assembly

9.0 Appendix

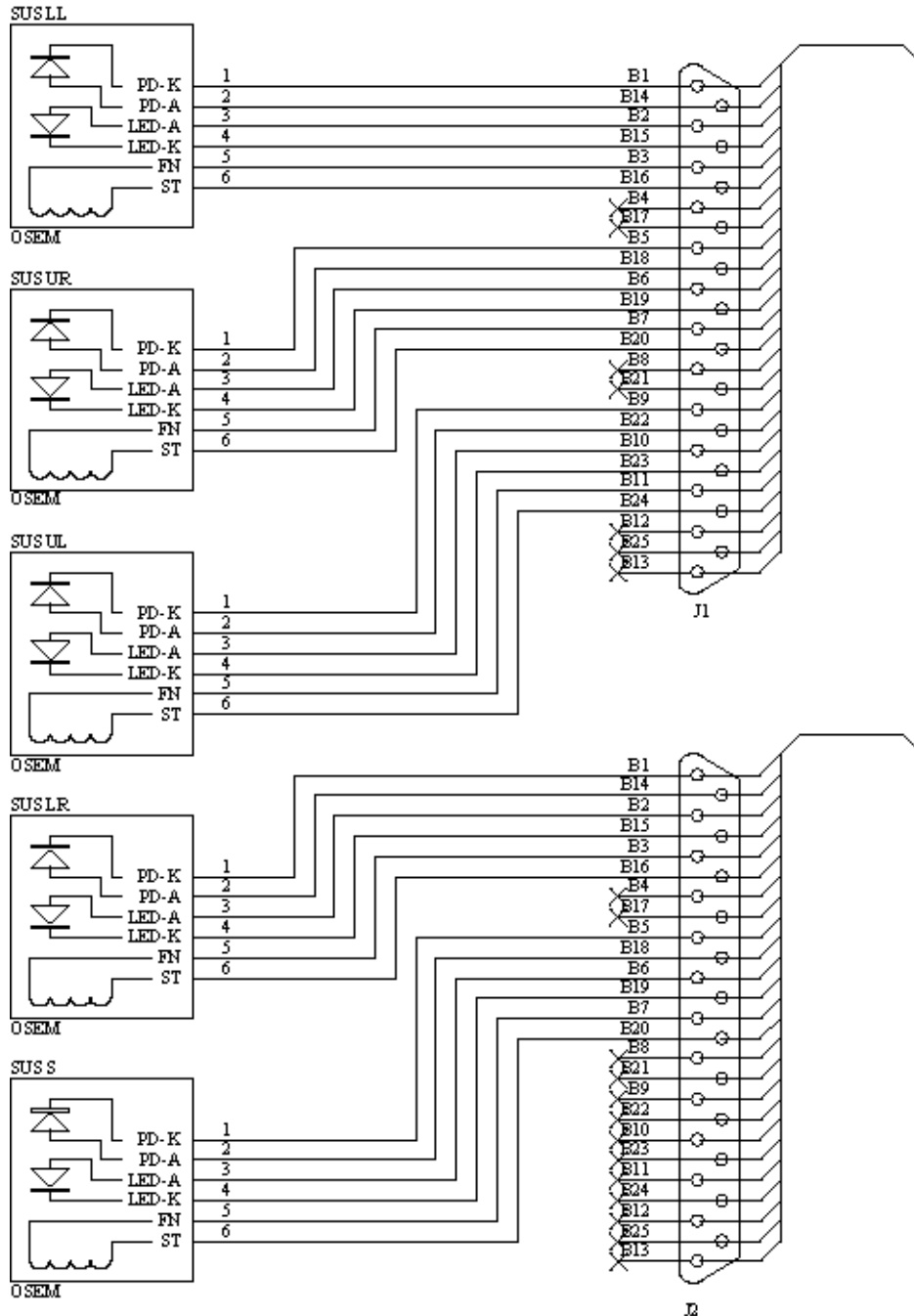

Sensor-Actuator (OSEM) Test Data.
Head Style: ___ Long ___ Short

Serial Number (pre/post-bake: date)		LED current (ma)	PD current (μ amp)	w/ filter	coil resistance	coil inductance	coil-body resistance _a	front face pt-pt R ^b	front face- body R ^c
	pre:								
	post:								
	pre:								
	post:								
	pre:								
	post:								
	pre:								
	post:								
	pre:								
	post:								
	pre:								
	post:								

- a. there should be no continuity between coil (either wire) and the body
- b. measured with probe tips diametrically opposed on the front face, placed close to the outside diameter
- c. will vary from point-to-point on the body; only 2 significant digits needed - objective is to verify continuity of charge-bleeding path