

REV.	DATE	DCN #	DRAWING TREE #
A	20 JUL 2007	E070186-00-D	

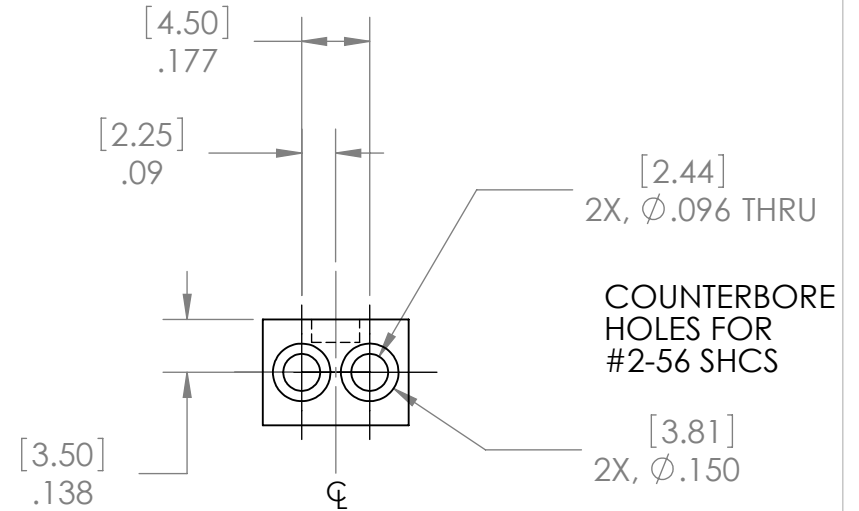
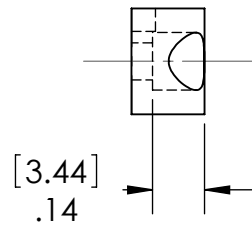
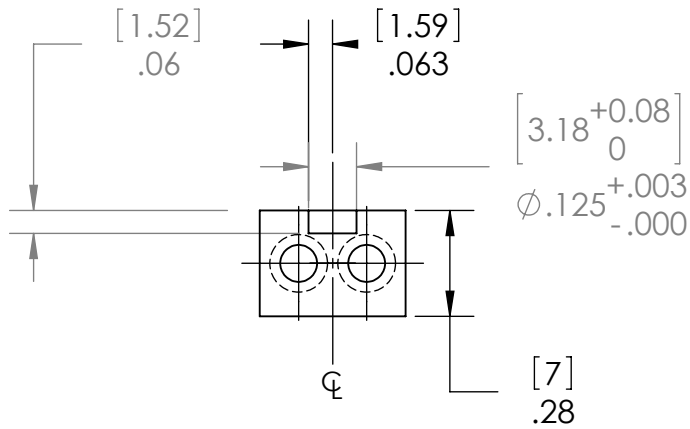
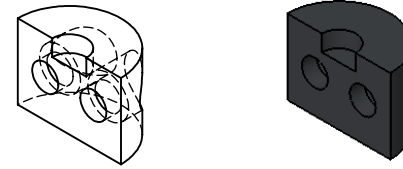
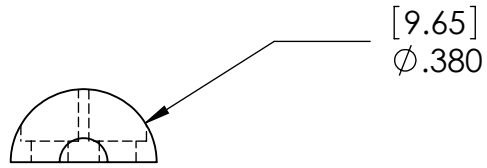

NOTES: (UNLESS OTHERWISE SPECIFIED)			LIGO		CALIFORNIA INSTITUTE OF TECHNOLOGY MASSACHUSETTS INSTITUTE OF TECHNOLOGY IGR, GLASGOW UNIVERSITY GEO 600 GROUP	
1. DO NOT SCALE FROM DRAWING. 2. REMOVE ALL SHARP EDGES, R.02 MAX. 3. ALL MACHINING FLUIDS SHALL BE WATER SOLUBLE AND FREE OF SULFUR, CHLORINE AND SILICONE. 4. BAG AND TAG ALL PARTS INDIVIDUALLY EXAMPLE: D050XXX-A S/N 001.			DIMENSIONS ARE IN INCHES [mm]		SCOTTISH UNIVERSITIES PHYSICS ALLIANCE TECHNOLOGY FOR EXPERIMENTAL & OBSERVATIONAL PHYSICS IN SCOTLAND (TEOPS)	
			TOLERANCES: .XX ± 0.01 .XXX ± 0.005 ANGULAR ± 0.5 °		SYSTEM ADVANCED LIGO	
			MATERIAL 304 SSSL		SUB-SYSTEM SUSPENSIONS OMC	
			FINISH N/A		NEXT ASSY LIGO-D070067	
			PART NAME WIRE CLAMP 4 OPTICAL BENCH			
DRAWN C. TORRIE 7 MAY 2007		CHECKED D. BRIDGES		SIZE A		DWG. NO. D070213
APPROVED				SCALE: NTS		PROJECTION: SHEET 1 OF 1
				REV. A		