

REV.	DATE	DCN #	DRAWING TREE #
A	10/18/05	E050270-00	

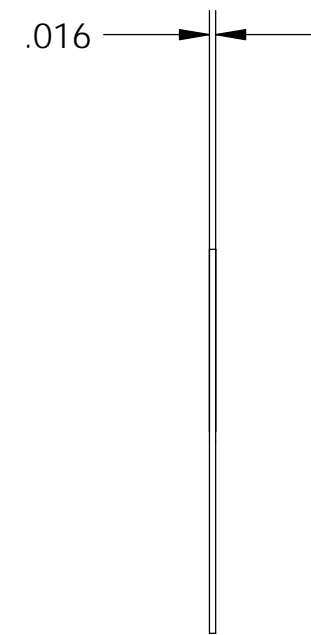
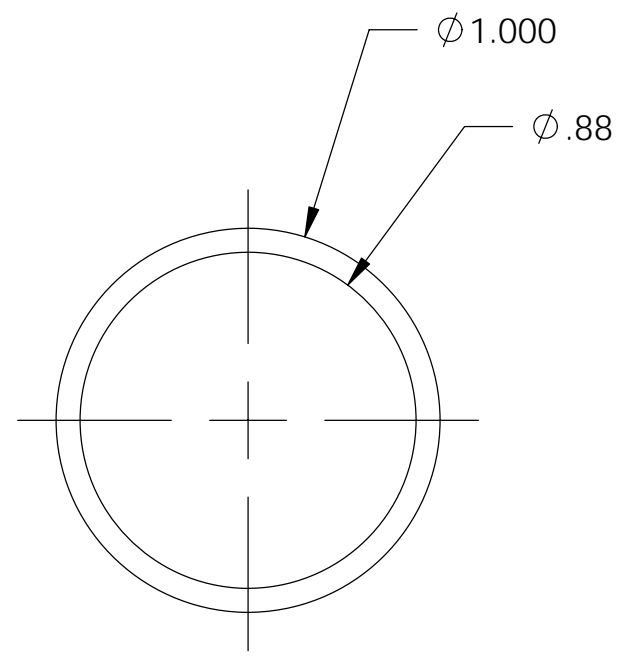

PARTS LIST															
<p><b>NOTES: (UNLESS OTHERWISE SPECIFIED)</b></p> <p>1. DO NOT SCALE FROM DRAWING. 2. REMOVE ALL SHARP EDGES, R.02 MIN. 3. ALL MACHINING FLUIDS SHALL BE WATER SOLUBLE AND FREE OF SULFUR, CHLORINE AND SILICONE, SUCH AS CINCINNATI MILACRON'S CIMTECH 410 (STAINLESS STEEL)</p> <p>④ SCRIBE, ENGRAVE OR STAMP DRAWING PART NUMBER, REVISION ON NOTED SURFACE OF PART AND THEN A THREE DIGIT SERIAL NUMBER. SERIAL NUMBERS START AT 001 FOR THE FIRST PART AND PROCEED CONSECUTIVELY. USE .07" HIGH CHARACTERS. A VIBRATORY TOOL MAY BE USED. EXAMPLE: D020188-00</p>		<p>DIMENSIONS ARE IN INCHES</p> <p>TOLERANCES: .XX ± 0.01 .XXX ± 0.005</p> <p>ANGULAR ± 0.5 °</p>													
<p><b>MATERIAL</b> Sterling silver</p>		<p><b>FINISH</b> 32 μ inch</p>													
<table border="1"> <thead> <tr> <th></th> <th>NAME</th> <th>DATE</th> </tr> </thead> <tbody> <tr> <td><b>DRAWN</b></td> <td>M. R. Smith</td> <td>10-11-05</td> </tr> <tr> <td><b>CHECKED</b></td> <td></td> <td></td> </tr> <tr> <td><b>APPROVED</b></td> <td></td> <td></td> </tr> </tbody> </table>			NAME	DATE	<b>DRAWN</b>	M. R. Smith	10-11-05	<b>CHECKED</b>			<b>APPROVED</b>			<p><b>SYSTEM</b> 40 METER</p> <p><b>SUB-SYSTEM</b> OMC</p> <p><b>NEXT ASSY</b></p> <p><b>PART NAME</b> AG WASHER OMC</p>	
	NAME	DATE													
<b>DRAWN</b>	M. R. Smith	10-11-05													
<b>CHECKED</b>															
<b>APPROVED</b>															
<p>SN 001</p>		<p><b>SIZE</b> B</p>	<p><b>DWG. NO.</b> D050367-A</p>												
		<p><b>SCALE:</b> 2:1</p>	<p><b>PROJECTION:</b>  SHEET 1 OF 1</p>												

8 7 6 5 4 3 2 1

D  
C  
B  
A

D  
C  
B  
A

8 7 6 5 4 3 2 1