

REV.	DATE	DCN #	DRAWING TREE #
A	FEB 17th 2006	E060057-00	E060059-A

4X, ϕ .170 THRU
 \square ϕ .31, ∇ .175

ϕ 2.850
 BOLT CIRCLE

SCRIBE THE LETTER "R" ONTO FACE

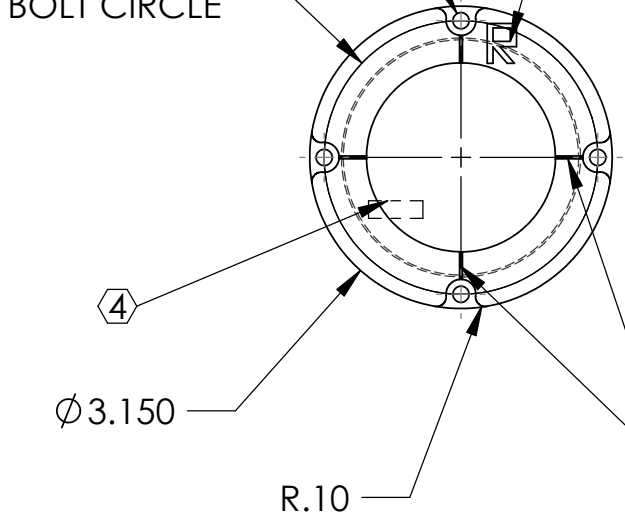

R .01/ .03

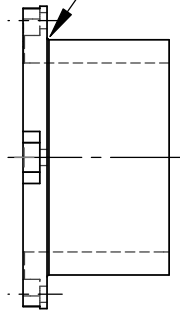

ϕ 2.450

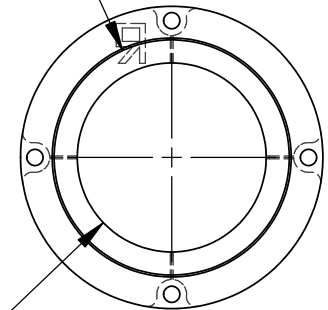

ϕ 1.969
 THRU

ADD VENT GROOVES
 .02" WIDE BY .02" DEEP

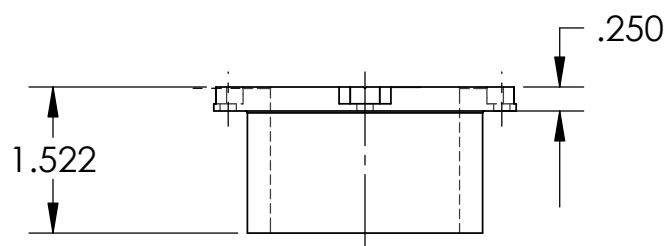
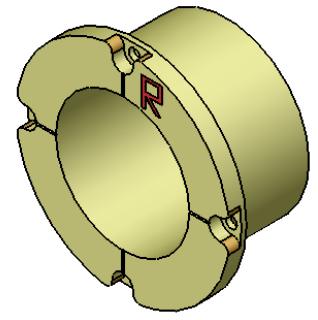

NOTES: (UNLESS OTHERWISE SPECIFIED)

- DO NOT SCALE FROM DRAWING
 - REMOVE ALL SHARP EDGES, R.02 MAX.
 - ALL MACHINING FLUIDS SHALL BE WATER SOLUBLE AND FREE OF SULFUR, CHLORINE AND SILICONE, SUCH AS CINCINNATI MILACRON'S CIMTECH 410 (STAINLESS STEEL)
- ④ SCRIBE, ENGRAVE OR STAMP DRAWING PART NUMBER ON NOTED SURFACE OF PART AND THEN A THREE DIGIT SERIAL NUMBER. SERIAL NUMBERS START AT 001 FOR THE FIRST PART AND PROCEED CONSECUTIVELY. USE .07" HIGH CHARACTERS. EXAMPLE: D020188-001. A VIBRATORY TOOL MAY BE USED.

DIMENSIONS ARE IN INCHES

TOLERANCES:
 .XX \pm 0.01
 .XXX \pm 0.005

ANGULAR \pm 0.5 °

MATERIAL
 6061-T6-Al

FINISH
 32 μ inch

	NAME	DATE
DRAWN	C Torrie	5TH JULY 2004
CHECKED	J Romie	17 SEPT 2004
APPROVED		

LIGO CALIFORNIA INSTITUTE OF TECHNOLOGY
 MASSACHUSETTS INSTITUTE OF TECHNOLOGY
 IGR, GLASGOW UNIVERSITY GEO 600 GROUP

SYSTEM ADVANCED LIGO

SUB-SYSTEM SUS

NEXT ASSY D040161 & D040165

PART NAME REACTION TEST MASS BUNG INSERT

SIZE **DWG. NO.** D040422 **REV.** A

SCALE: NTS **PROJECTION:** **SHEET 1 OF 1**