

NOTES: (UNLESS OTHERWISE SPECIFIED)

1. DIMENSIONS IN INCHES

2. ALL MACHINING FLUIDS SHALL BE WATER SOLUBLE AND FREE OF SULFUR, CHLORINE AND SILICONE, SUCH AS CINCINNATI MILACRON'S CIMTECH 410 (STAINLESS STEEL)

③ USING A VIBRATORY TOOL MARK PART AS INDICATED

REV.	DATE	DCN #	DRAWING TREE #
A	24 JUNE 2004	E040303-00	

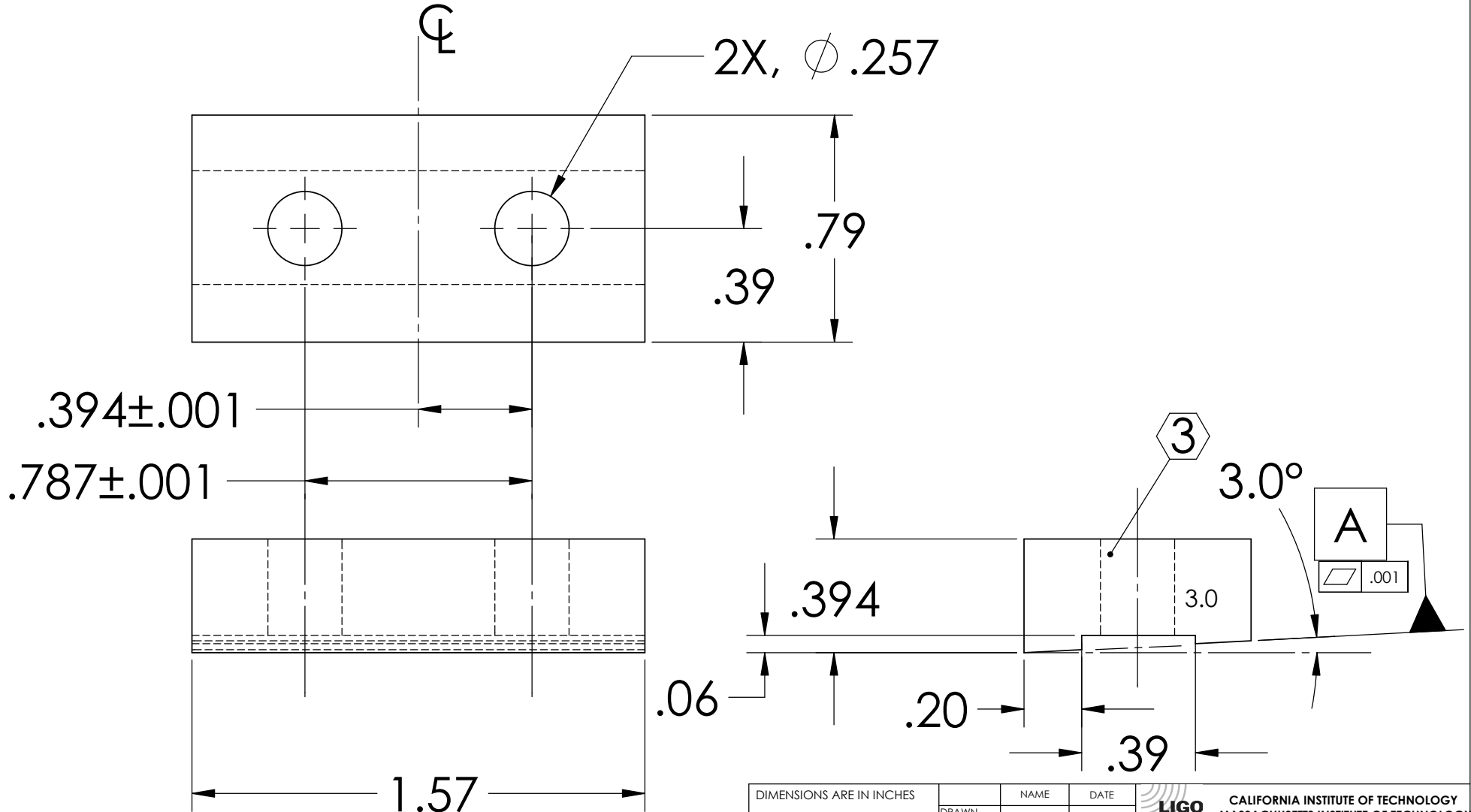

DIMENSIONS ARE IN INCHES		NAME	DATE	CALIFORNIA INSTITUTE OF TECHNOLOGY MASSACHUSETTS INSTITUTE OF TECHNOLOGY
TOLERANCES: .XX ±0.01 .XXX ±0.005 ANGULAR ±.25°		CIT/RJ	05/02	
MATERIAL		CHECKED		SYSTEM
300 Series Stainless				ADVANCED LIGO
FINISH				SUB-SYSTEM
				SUS
				NEXT ASSY
				LIBRARY OF CLAMPS
		COMMENTS:		PART NAME
				UPPER BLADE CLAMP UPPERSIDE ANGLED (3.0°)
		SIZE	DWG. NO.	REV.
		A	D020689	A
		SCALE: NTS		SHEET 1 OF 1

