

REV.	DATE	DCN #	DRAWING TREE #
A	Fall'02		
B	7/16/03	E030373-00-E	

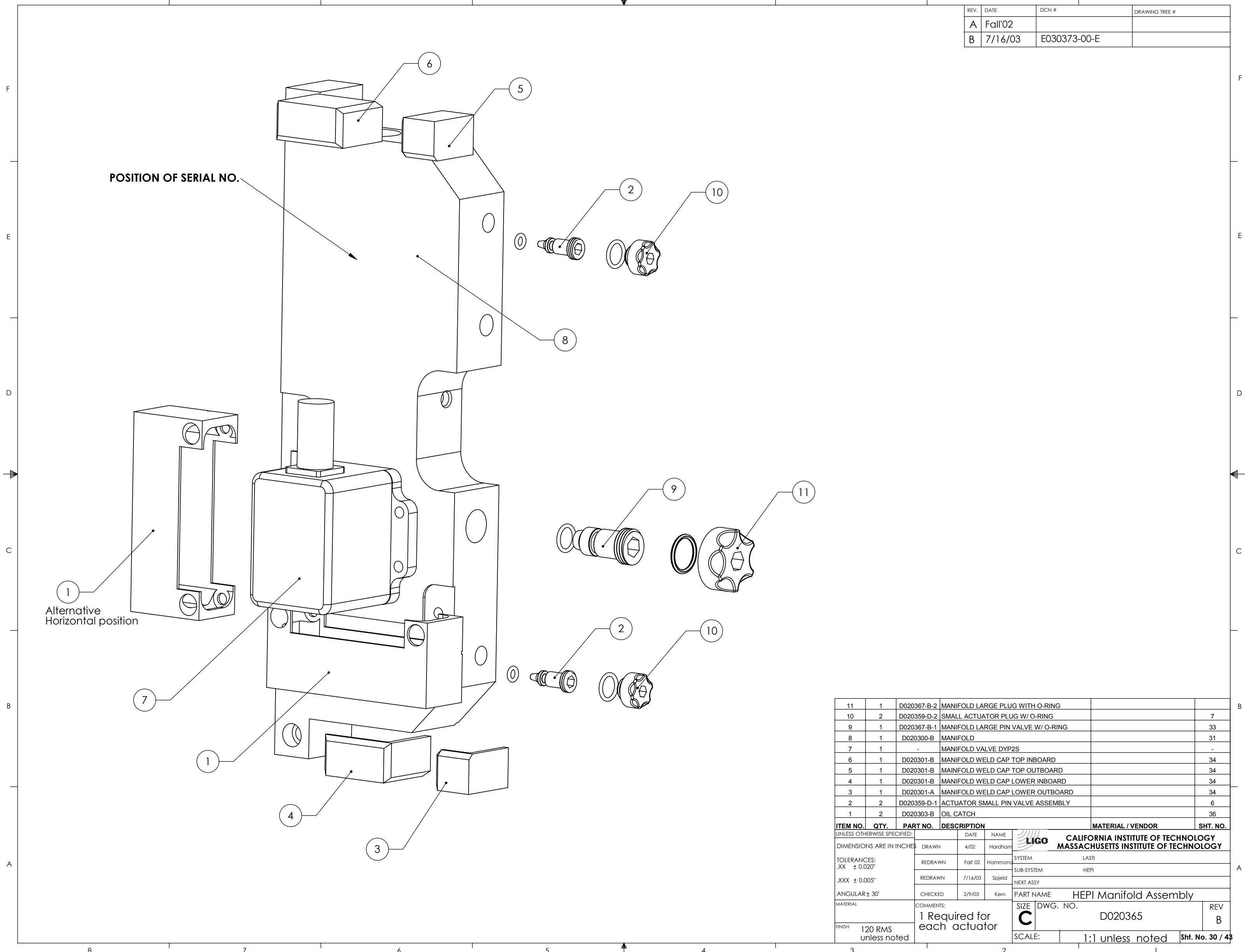

POSITION OF SERIAL NO.

Alternative Horizontal position

ITEM NO.	QTY.	PART NO.	DESCRIPTION	MATERIAL / VENDOR	SHT. NO.
11	1	D020367-B-2	MANIFOLD LARGE PLUG WITH O-RING		
10	2	D020359-D-2	SMALL ACTUATOR PLUG W/ O-RING		7
9	1	D020367-B-1	MANIFOLD LARGE PIN VALVE W/ O-RING		33
8	1	D020300-B	MANIFOLD		31
7	1	-	MANIFOLD VALVE DYP2S		-
6	1	D020301-B	MANIFOLD WELD CAP TOP INBOARD		34
5	1	D020301-B	MANIFOLD WELD CAP TOP OUTBOARD		34
4	1	D020301-B	MANIFOLD WELD CAP LOWER INBOARD		34
3	1	D020301-A	MANIFOLD WELD CAP LOWER OUTBOARD		34
2	2	D020359-D-1	ACTUATOR SMALL PIN VALVE ASSEMBLY		6
1	2	D020303-B	OIL CATCH		36

UNLESS OTHERWISE SPECIFIED:	DATE	NAME	SYSTEM	LASTI
DRAWN	4/02	Hardham	SYSTEM	LASTI
REDRAWN	Fall' 02	Hammond	SUB-SYSTEM	HEPI
REDRAWN	7/16/03	Spjeld	NEXT ASSY	
CHECKED	2/9/03	Kern	PART NAME	HEPI Manifold Assembly
COMMENTS:	1 Required for each actuator		SIZE DWG. NO.	REV
MATERIAL			C	B
FINISH	120 RMS unless noted	SCALE:	1:1 unless noted	Sht. No. 30 / 43

LIGO CALIFORNIA INSTITUTE OF TECHNOLOGY
 MASSACHUSETTS INSTITUTE OF TECHNOLOGY

SIZE DWG. NO. D020365 REV B

SCALE: 1:1 unless noted Sht. No. 30 / 43