

# PSL - PMC

## 35.5 MHz Frequency Reference

Engineering Change Order History		
ECO number	Date	Originator
1		
2		
3		
4		
5		

Measurement of Vp-p at output of Mixer Out and PC Out at 21.5 MHz into 50 ohms with 5 VDC applied to U17 pin 12.

Mixer Out: 8.0 Vp-p  
PC Out: 9.7 Vp-p

Normal Operating Currents in above condition:

+24 VDC Supply: 0.21 A  
-24 VDC Supply: 0.03 A  
+10 VDC Supply: 0.32 A

50 Ohm "T" Attenuator Values

Atten	Series Element	Shunt Element
3 dB	8.2 Ohm	150 Ohm
6 dB	16 Ohm	68 Ohm
10 dB	27 Ohm	36 Ohm
20 dB	39 Ohm	10 Ohm

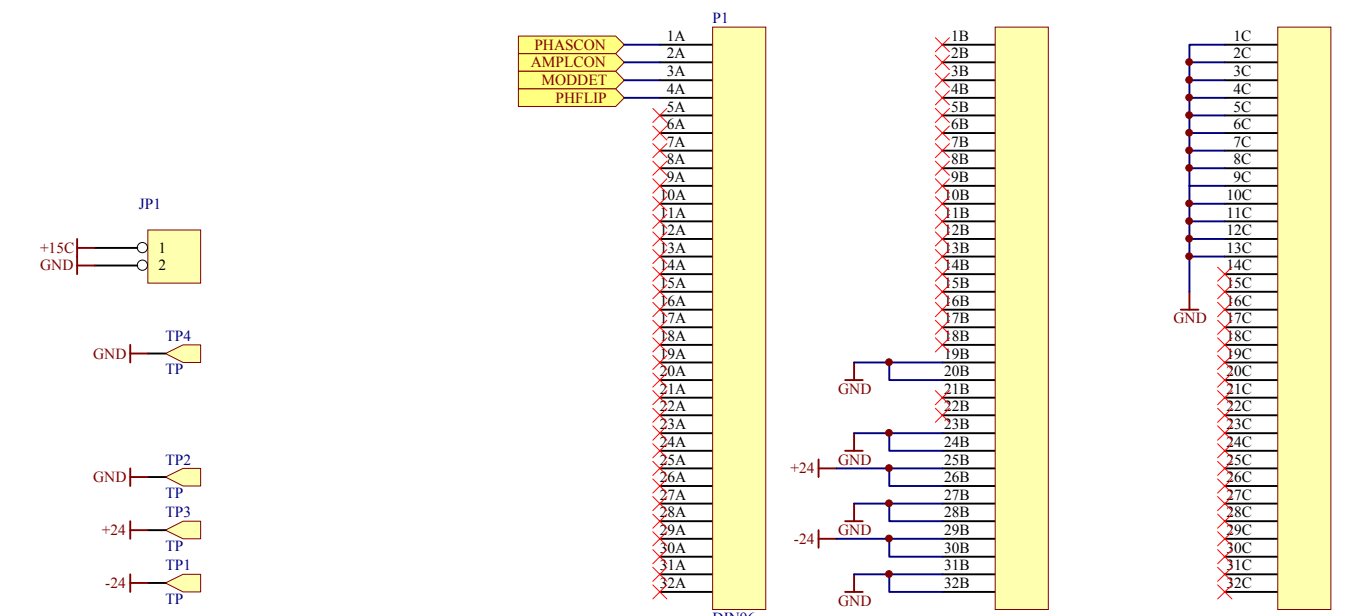
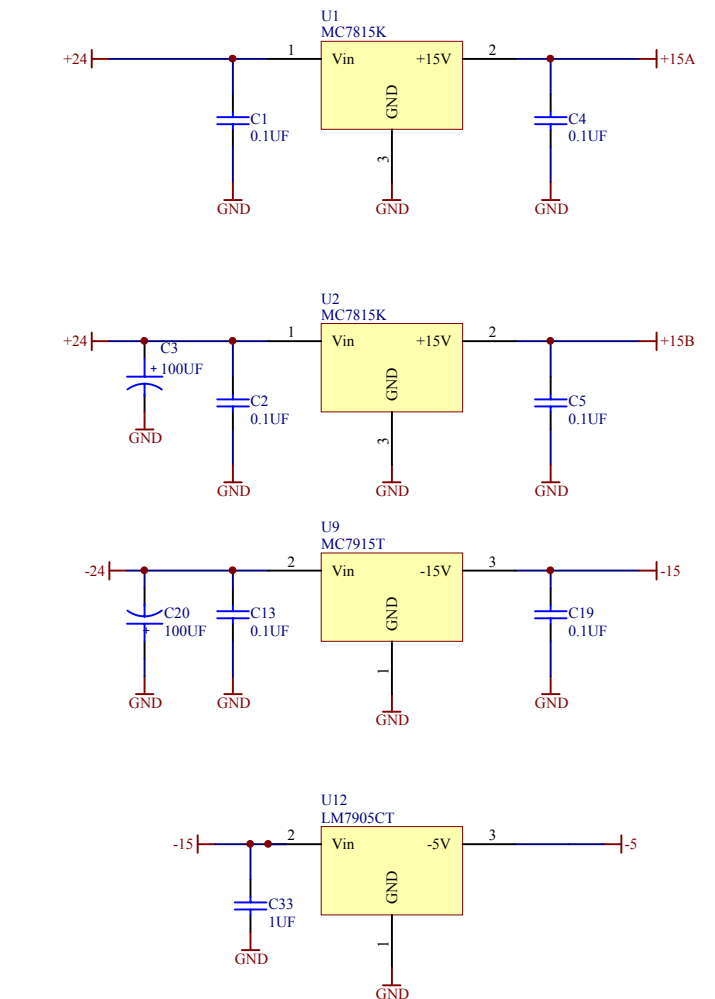
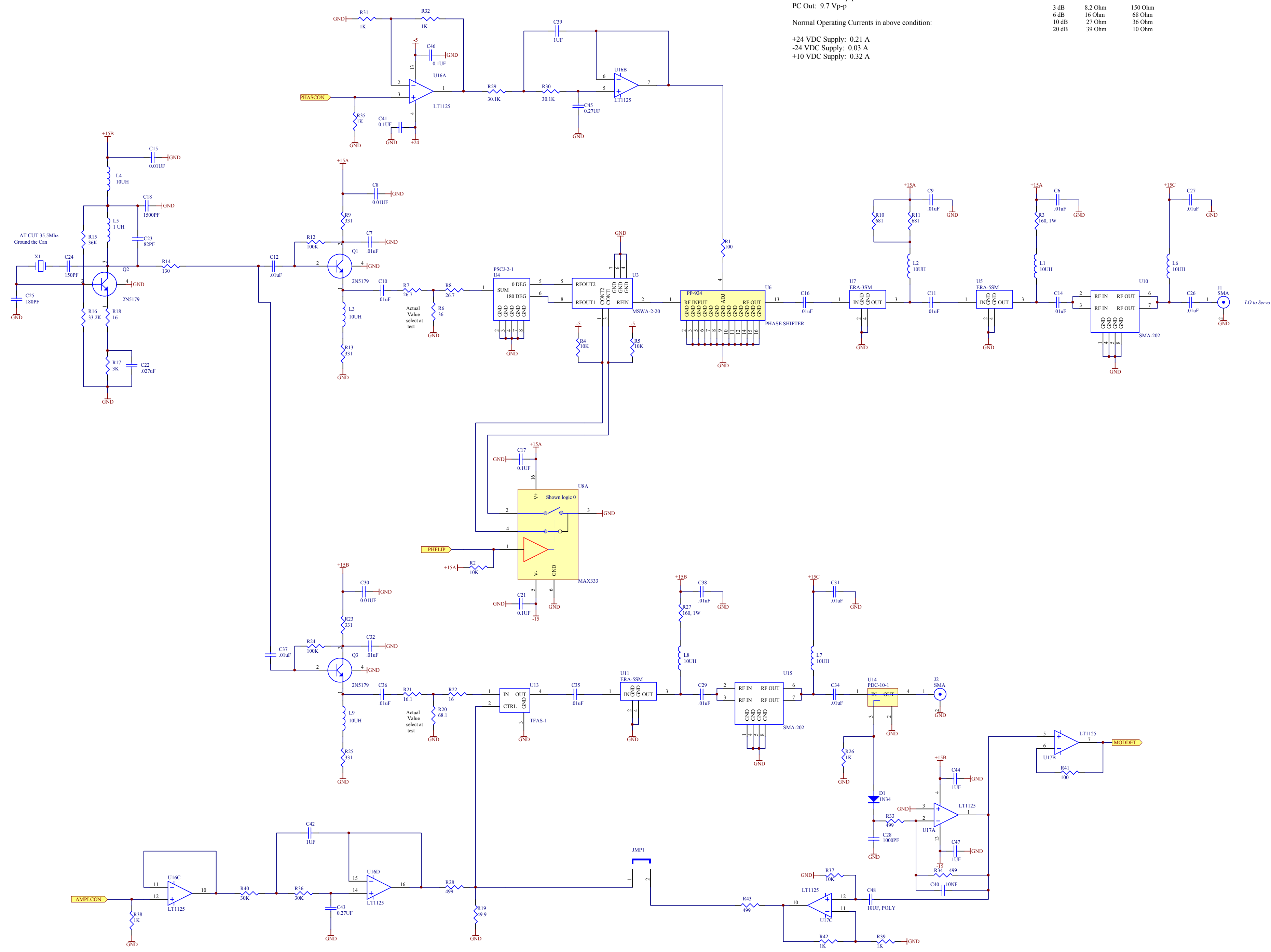

REV	DATE	DRAWN BY	CHECKED BY	DCC	DCN / DESCRIPTION