

Advanced LIGO Subsystem Descriptions

NSF Review of Advanced LIGO Project

Dennis Coyne, Caltech

Peter Fritschel, MIT

Pre-stabilized laser (PSL)

- **High power laser: 180 Watts**

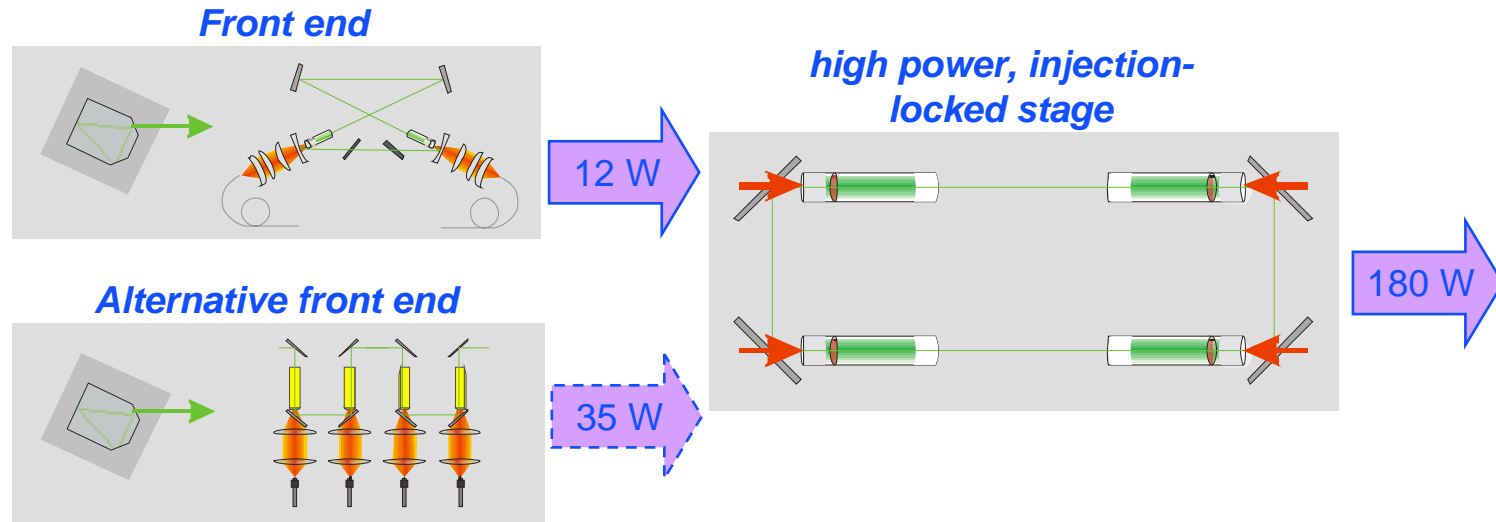

- **Laser power stabilization**
- **Laser frequency pre-stabilization**
 - » Wideband frequency actuation for further stabilization
- **Pre-mode cleaner for spatial clean-up and high-frequency filtering**
- **Diagnostic tools**
- **Laser safety measures**

PSL: stabilization systems

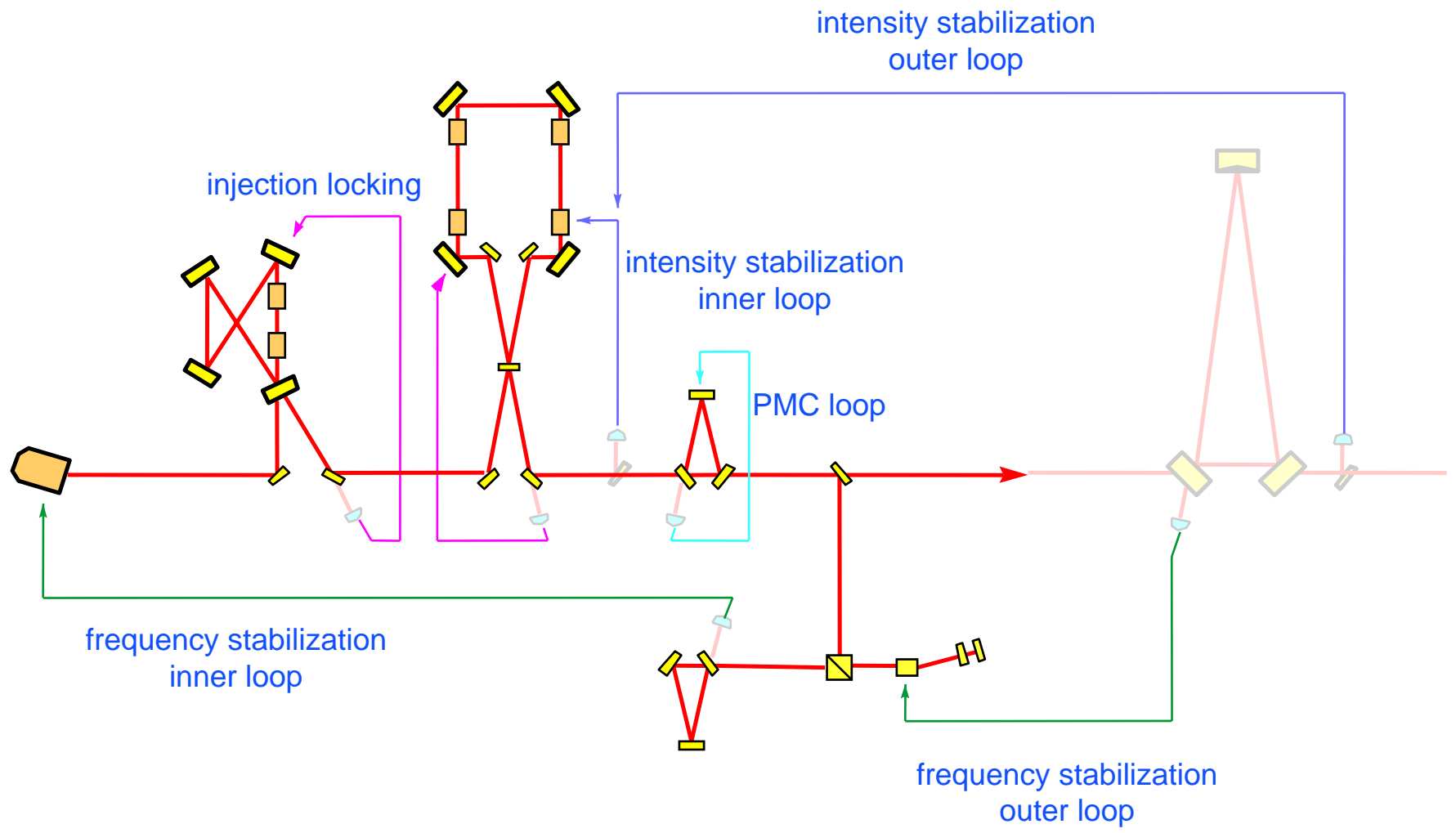

Input Optics

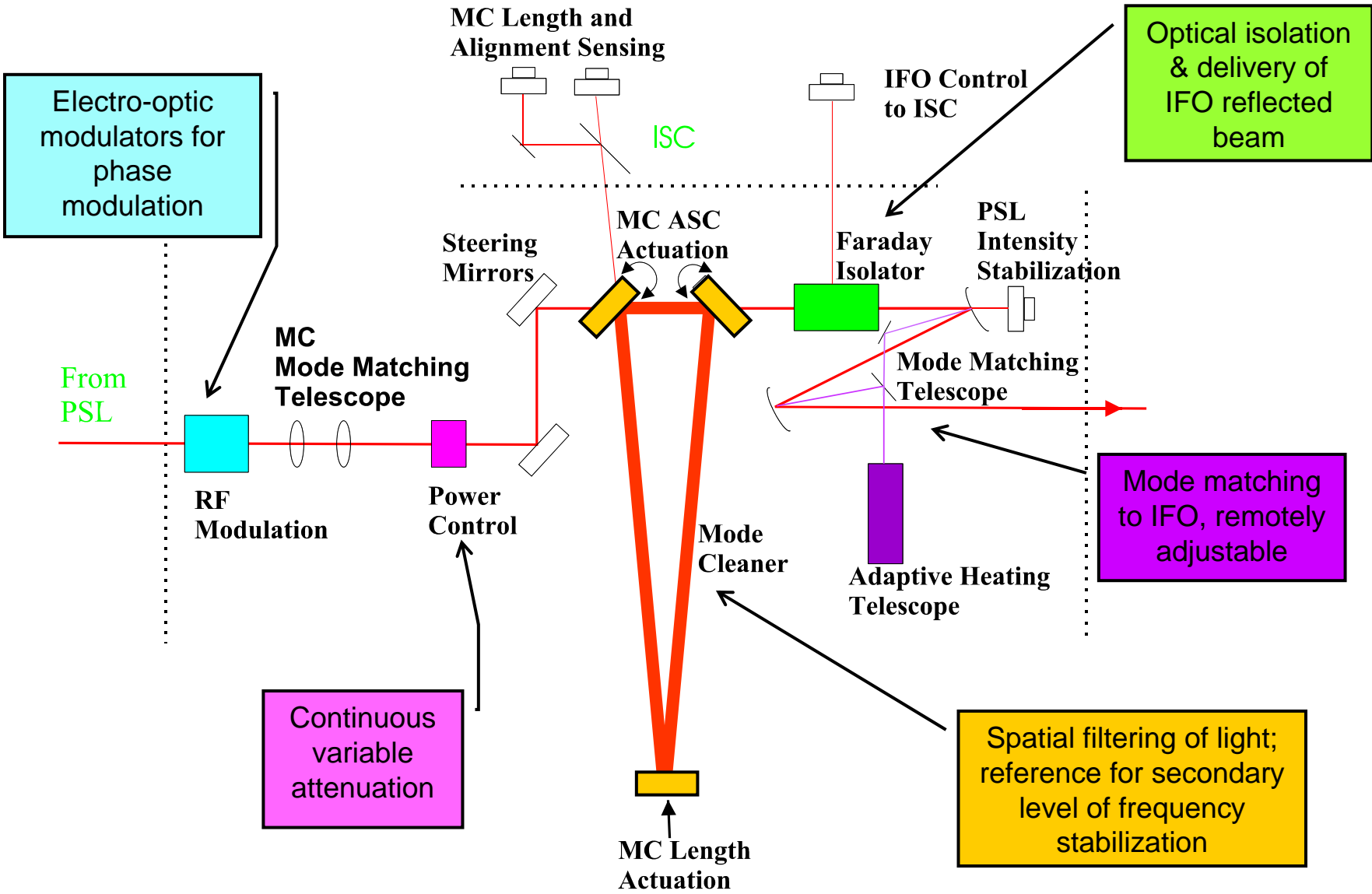

Core Optics Components

- Substrate procurement
- Substrate polishing
- Dielectric coatings
- Metrology

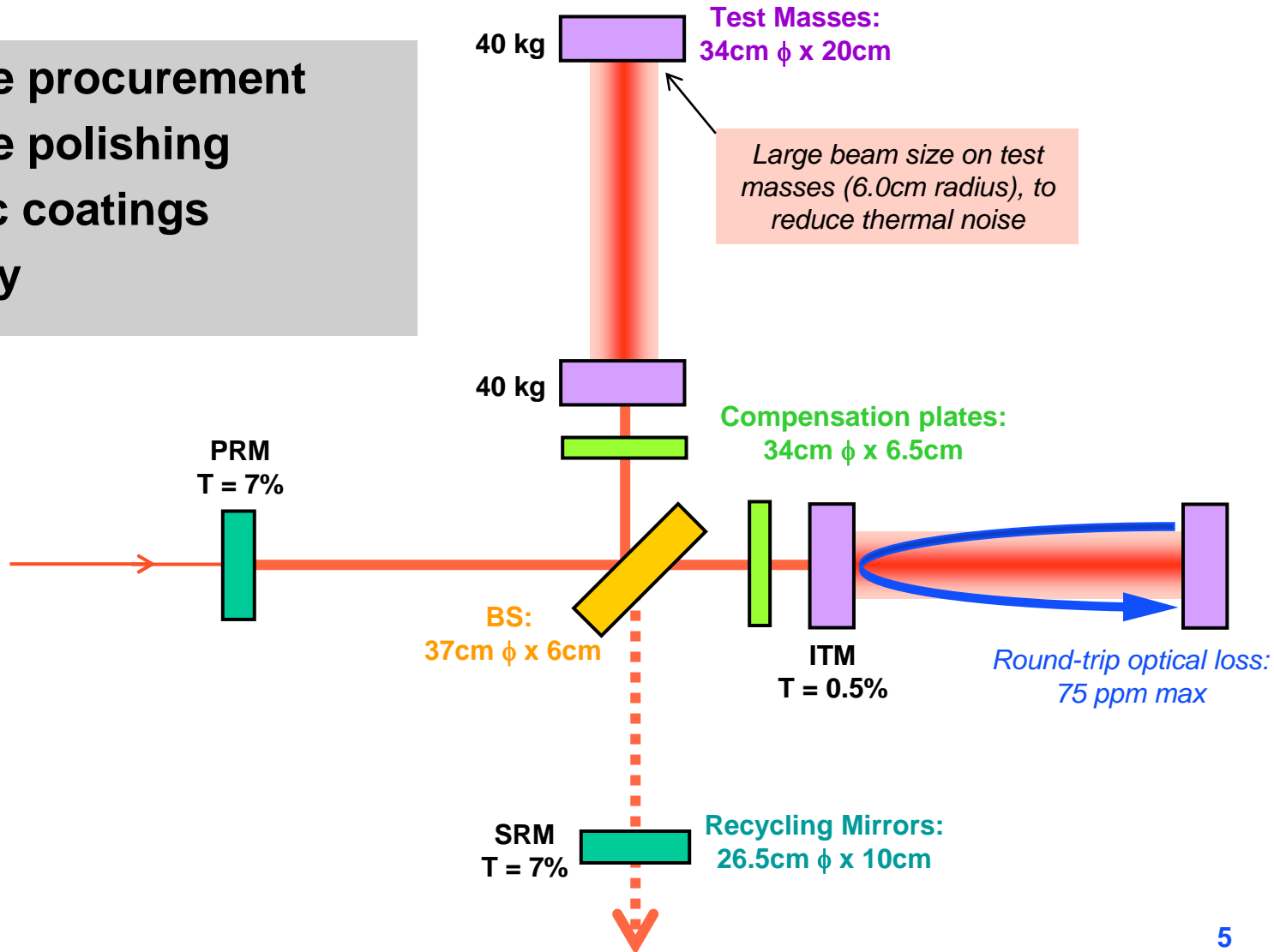

Core Optics Components

- **Substrates**
 - » Fused silica: Heraeus (for low absorption) or Corning
 - » Specific grade and absorption depends on optics
 - » ITMs and BS most critical (need low absorption and good homogeneity)
- **Polishing**
 - » Low micro-roughness (< 1 angstrom-rms)
 - » Low residual figure distortion (< 1 nm-rms over central 120mm diameter)
 - » Accurate matching of radii-of-curvature
 - » Surfaces for attachment of suspension fibers
- **Dielectric coatings**
 - » Low absorption (0.5 ppm or smaller)
 - » Low scatter
 - » Low mechanical loss ($< 2e-4$)
- **In-house Metrology**
 - » ROC, figure distortion, scattering, absorption

Auxiliary Optics Subsystem (AOS)

- **Initial Alignment System**
 - » Surveying support for proper installation of components
- **Photon calibrators**
 - » Calibration tool using photon pressure of a modulated laser beam
- **Viewports**
 - » For beams entering and exiting vacuum
- **Optical levers**
 - » Orientation monitors of each suspended optic, relative to the floor
- **In-vacuum stray light control**
 - » Baffles and beam dumps for diffuse scattering and ghost beams
- **Beam reducing telescopes**
 - » For pick-off beams and the output beam
- **Thermal compensation system**
 - » Senses thermal distortions of core optics and corrects by adding compensating heat

Thermal compensation system

Absorption and thermal lensing at high power operation

Optic	Substrate			Surface		
	Power	absorbed power	Induced lens	Power	absorbed power	Induced lens
ITM	1 kW	120 mW	$(6.8 \text{ km})^{-1}$	800 kW	400 mW	$(100 \text{ km})^{-1}$
ETM				800 kW	400 mW	$(100 \text{ km})^{-1}$

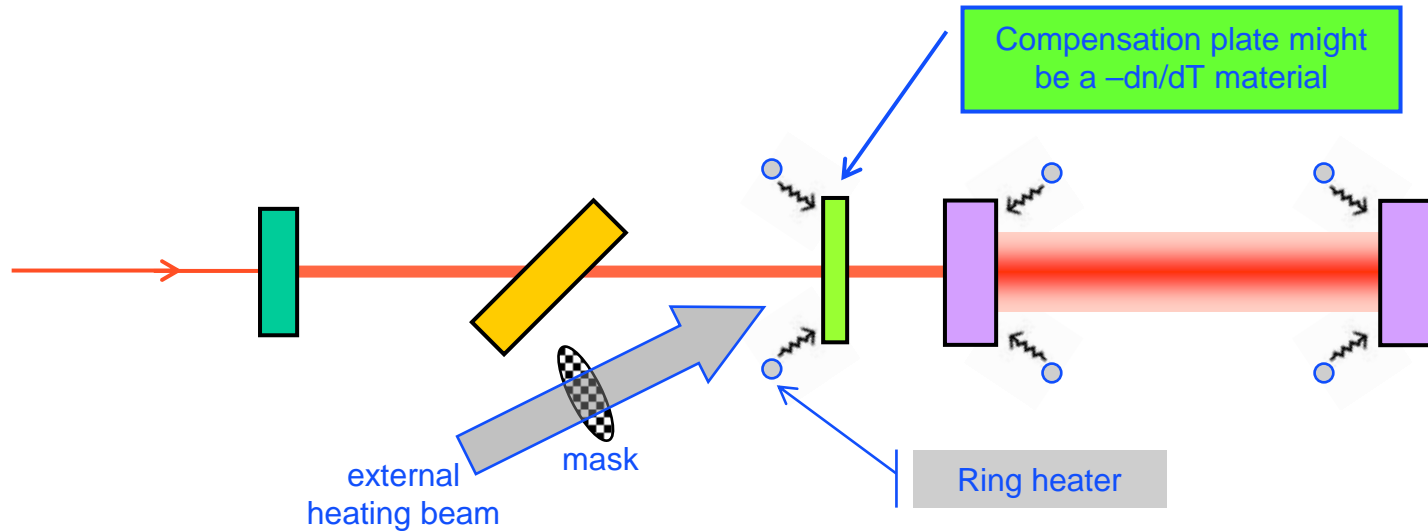

- **Specifies input beam modulation scheme to:**
 - » Sense the global interferometer lengths
 - » Sense the global interferometer mirror angles
- **Detection tables for all sensed beams**
 - » Opto-mechanical hardware, photodetectors
 - » All beams involved in critical control loops will be detected in-vacuum, on vibrationally isolated tables
- **Digital controls hardware and software for all length and alignment controls**
 - » Including data conversion
- **Lock acquisition of the interferometer**
- **Readout of the gravitational wave channel**

ISC: DC detection & output mode cleaner

- **DC (homodyne) detection: decided in favor of in 2003**
 - » Interferometer is offset from the dark fringe (1-10 pm), and the resulting DC carrier field is used as the local oscillator for detecting the GW signal
 - » Less sensitive to input beam noise than RF (heterodyne) detection
 - » Quantum noise sensitivity as good as or better than RF detection

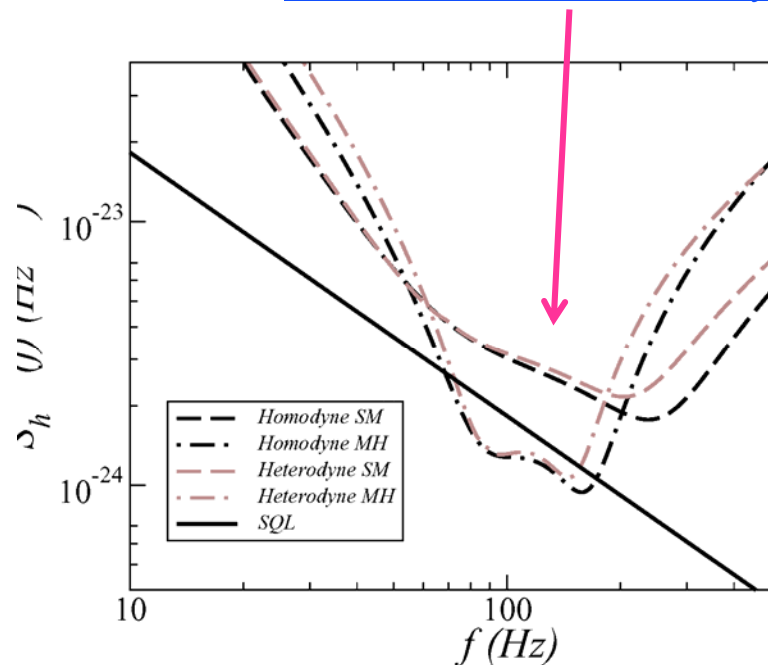

- **Output mode cleaner**

- » Needed to reject higher-order mode light at the output
- » Rejects RF sideband power for DC detection

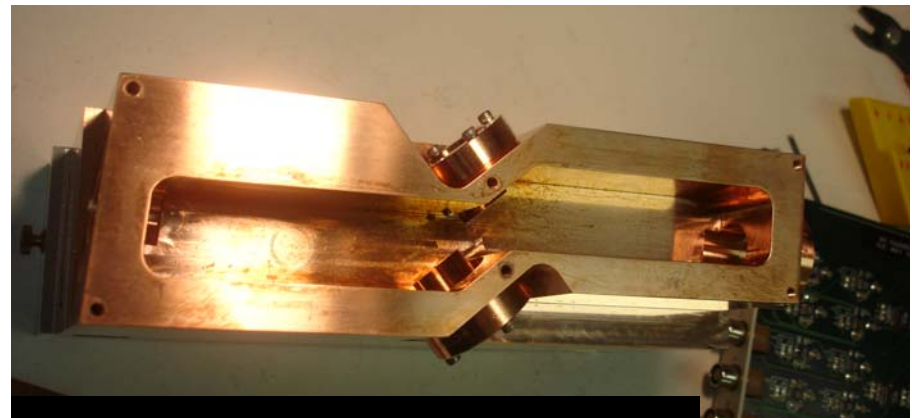

Caltech 40m prototype

- **Unstable optical spring when the SRC is detuned**
 - » ISC length control system will provide wideband feedback (~200 Hz) to stabilize (unstable mode at 50-60 Hz for nominal tuning)
- **Angular instability due to radiation torque**
 - » Led to choice of negative g-parameters for cavities: $1 - L/R = -0.93$
 - » Feedback stabilization provided by ISC alignment controls: challenge is to provide enough feedback to stabilize, without introducing noise
- **Parametric instabilities**
 - » Test mass mechanical modes can parametrically pump energy into higher-order cavity modes

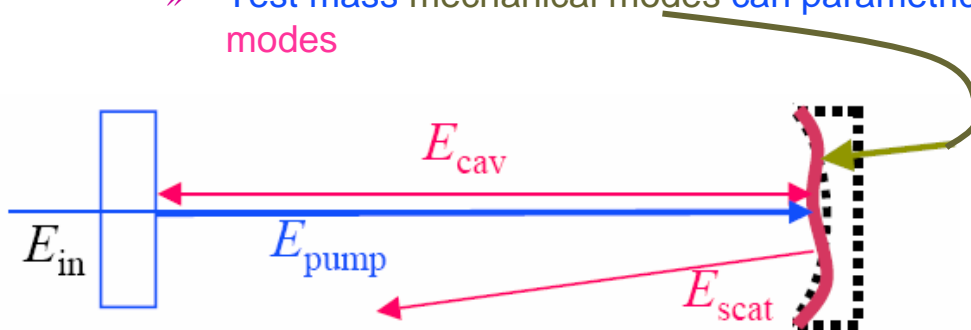

Mitigation options:

- reduce Q of mechanical modes by selective application of lossy material
- increase cavity mode loss by tuning coating aperture, and/or ITM transmission
- fine tune the cavity mode spectrum using the TCS actuation of ROCs, to avoid critical modes

- » Modeling of the phenomenon is being further refined (Braginsky, UWA, CIT)
- » Currently ~10 modes predicted to be unstable at full power

- **Configuration of recycling cavities**

- » Current design: Gouy phase shift in the RCs is very small; RCs are at the edge of stability, and thus rather degenerate (as in initial LIGO)
- » Alternative: include focusing elements in the RCs to achieve a significant Gouy phase shift
 - beam has to be expanded/reduced anyway, so just include the telescope in the cavity

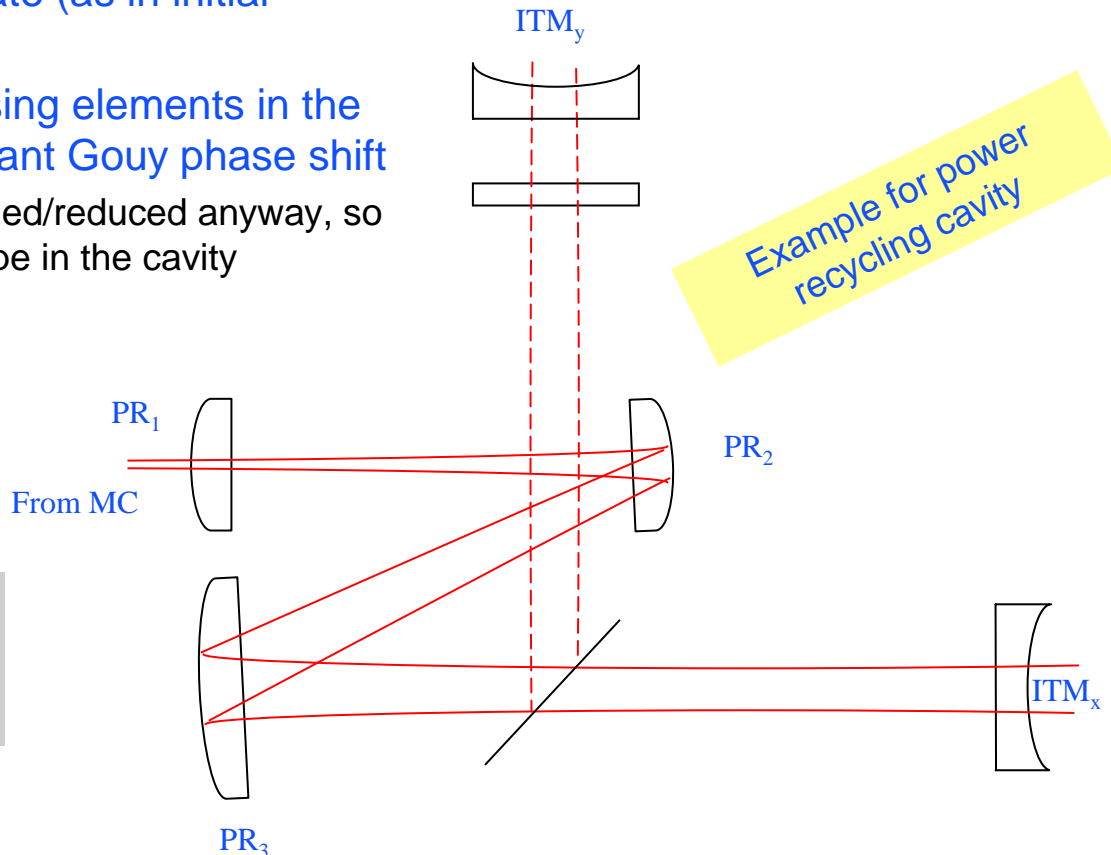

Stable configuration appears to have many advantages, and is being carefully studied

- **Concept:**

- » form a 'simple', relatively low-sensitivity interferometer between the ITM & ETM platforms
- » Use it to stabilize the 4km arm lengths at low frequencies (below a few Hertz)

- **Motivation:**

- » Arm length fluctuations are dominated by low frequency motions, $f < 0.5$ Hz; motion in this band (~100 nm-rms) not expected to be much lower than in initial LIGO (@LLO, w/ HEPI)
- » Reducing this rms by another factor of 10-100x could:
 - Make lock acquisition much simpler
 - Enable lock acquisition during times of high micro-seism
 - Possibly beneficial during interferometer operation as well

- **Status:**

- » Schemes for implementing an SPI are being considered
- » Falls in the domain of the ISC subsystem, if implemented

Interferometer performance estimate

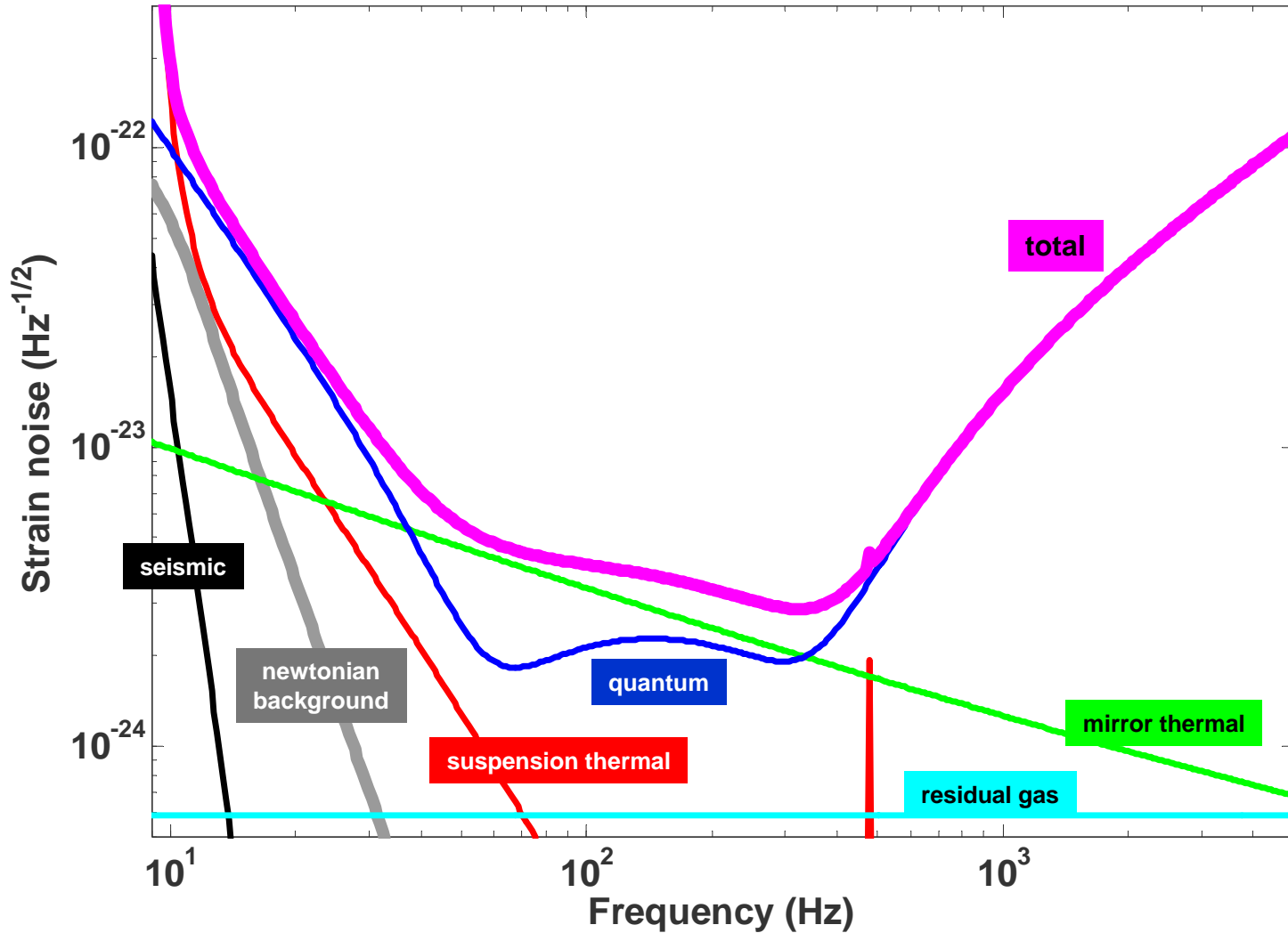

Interferometer performance estimate

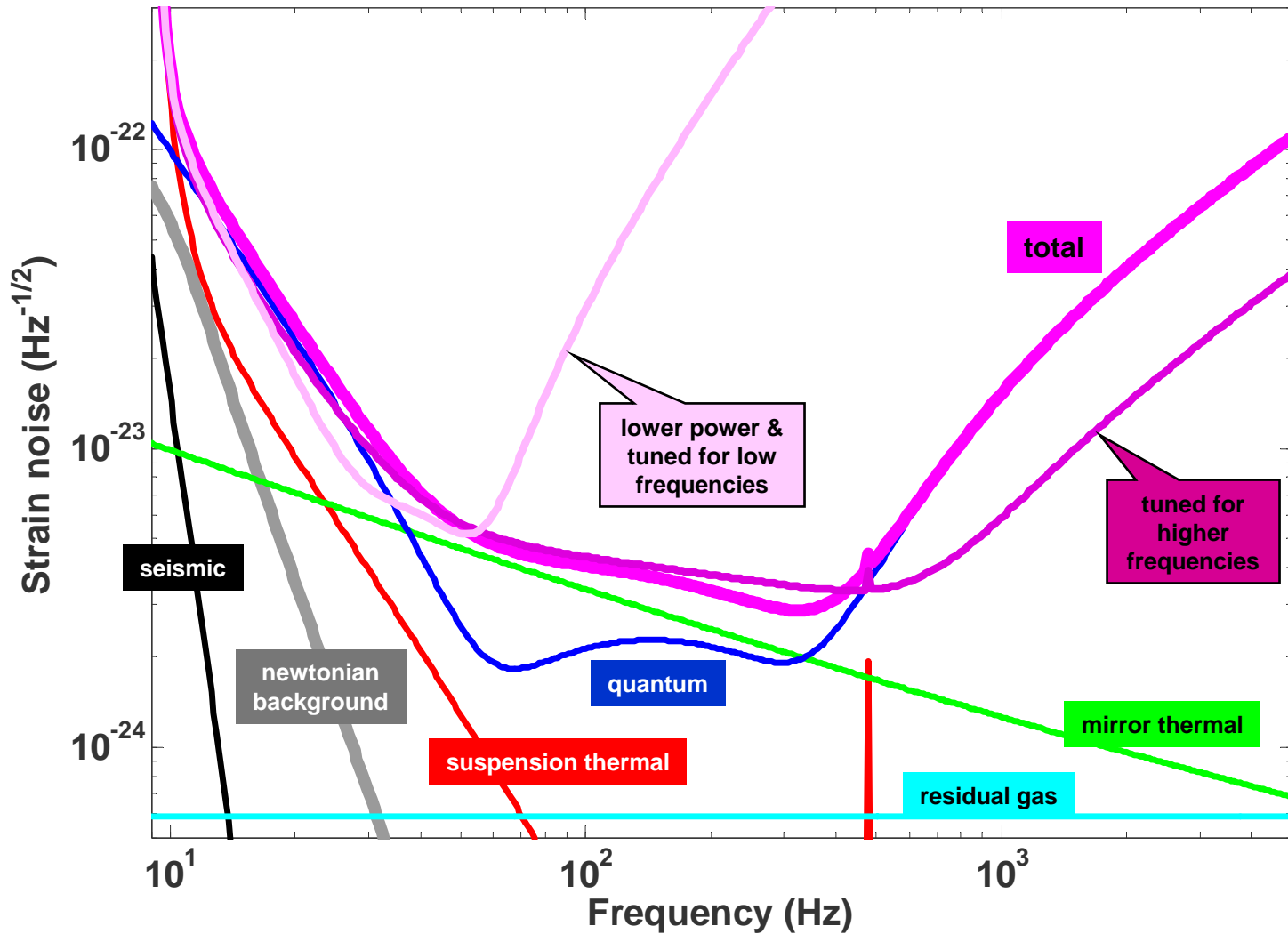

Mirror thermal noise contributors

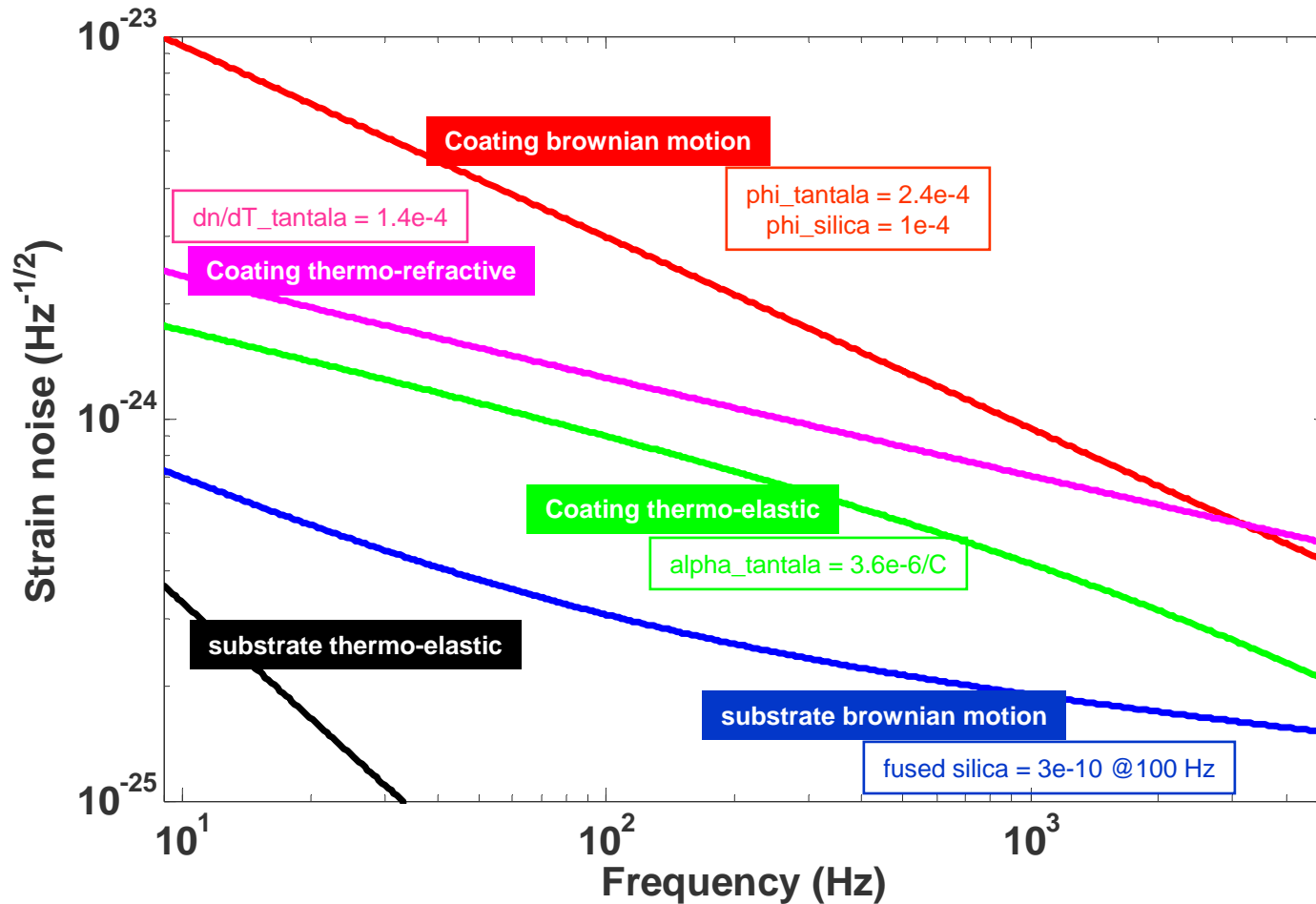

- **Two major LIGO prototype test facilities:**

- » **LIGO Advanced System Test Interferometer (LASTI) @MIT** – full scale tests of :
 - seismic isolation
 - suspensions, laser
 - mode cleaner
- » **40m Interferometer @Caltech**
 - Sensing/controls tests of readout
 - Lock acquisition
 - Engineering model for data acquisition, software

- **Support from LSC testbeds**

- » **Gingin Facility @Gingin, Australia** – high power cavity, for:
 - Thermal compensation: sensors and actuators
 - Parametric instabilities
- » **10m Interferometer @U of Glasgow** – readout
- » **Engineering Test Facility (ETF) @Stanford** – seismic isolation
- » **GEO600 @Hanover, Germany** – much more than a prototype! (test of the quasi-monolithic fused silica suspension)

- **Initial & enhanced LIGO**

- » Hydraulic External Pre-Isolator (HEPI)
- » Thermal Compensation System
- » High power modulators & isolators
- » Output mode cleaner & DC readout

LASTI (Triple Suspension in a HAM Chamber)



Gingin Facility



40 M Lab