

# Advanced LIGO Subsystems

NSF Review of the  
Advanced LIGO Project  
31 May 2006



Dennis Coyne, Caltech  
Peter Fritschel, MIT



## Part 1: Dennis Coyne

- **Advanced LIGO Technical Overview**
- **Subsystem Breakdown**
- **Subsystem Overviews:**
  - » **Control & Data System (CDS) Infrastructure**
    - Data Acquisition (DAQ, WBS 4.09)
    - Data Computing System (DCS, WBS 4.12)
  - » **Isolation:**
    - Seismic Isolation (SEI, WBS 4.02)
    - Suspensions (SUS, WBS 4.03)
  - » **Integration**
    - Systems Engineering (SYS, WBS 4.14.5)
    - Facility Modifications & Preparation (FMP, WBS 4.01)
    - Installation & System Test (INS, WBS 4.13)

## Part 2: Peter Fritschel

- » **Lasers & Optics**
  - Pre-Stabilized Laser (PSL, WBS 4.04)
  - Input Optics (IO, WBS 4.05)
  - Core Optic Components (COC, WBS 4.06)
  - Auxiliary Optics System (AOS, WBS 4.07)
- » **Global Interferometer Controls**
  - Interferometer Sensing & Controls (ISC, WBS 4.08)
- **Open Trade Studies/Options**
- **Performance**
- **System Test Beds**

## Retain infrastructure, vacuum chambers, and Initial LIGO layout of power recycled interferometer

- **Recombined Fabry-Perot Michelson**
  - » Signal recycling (increase sensitivity & add tunability)
- ~20x higher input power (lower shot noise)
- 40 kg masses (lower photon pressure noise)
- Fused Silica Suspension (lower thermal noise)
- Active seismic isolation, quadruple pendulum suspensions (lower frequency response)
- Leads to:
  - » Increased Thermal Compensation
  - » Improved Scattered Light Control
  - » Addition of Output Optical Filtering (Mode Cleaner)
  - » Seismically isolated, in-vacuum detection
  - » Increased Control Complexity
  - » Modifications to the Vacuum Envelope

### ADVANCED LIGO LAYOUT

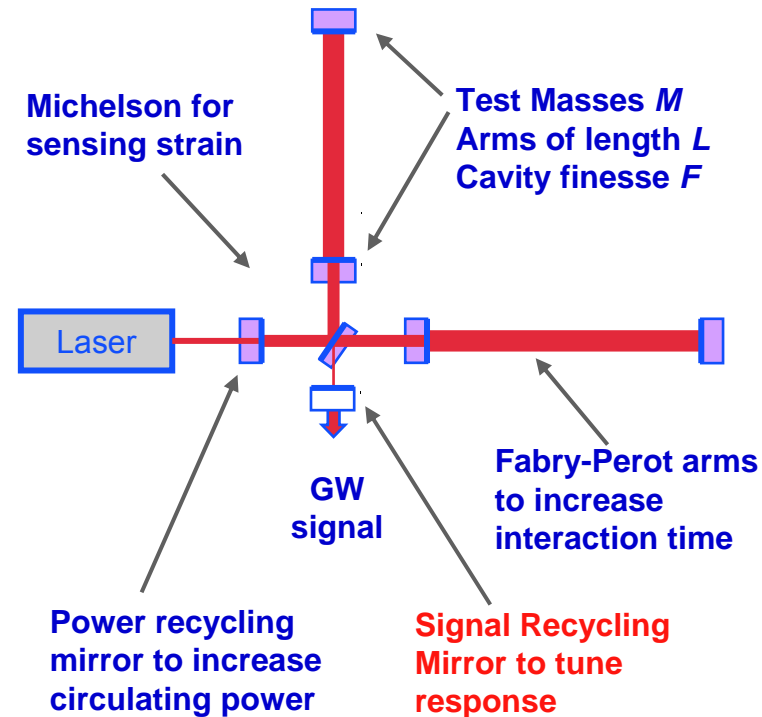

# Advanced LIGO Design Features

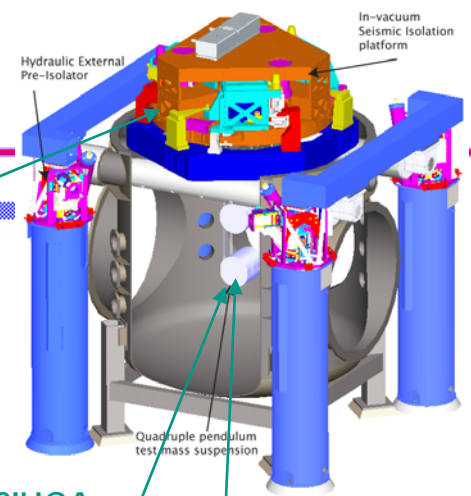
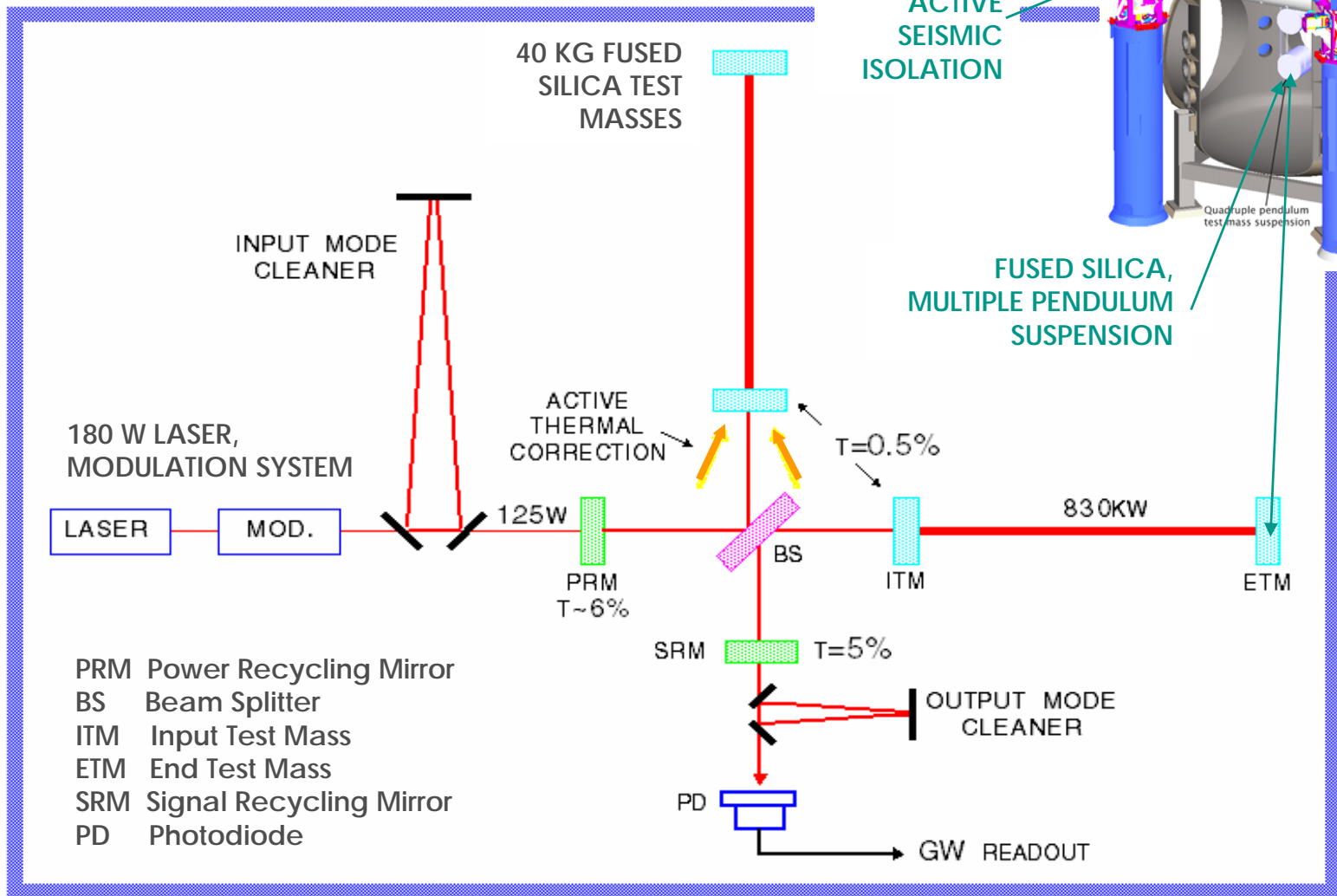

- PRM Power Recycling Mirror
- BS Beam Splitter
- ITM Input Test Mass
- ETM End Test Mass
- SRM Signal Recycling Mirror
- PD Photodiode

- **Data Acquisition System Infrastructure**
  - » receive, digitize, format and store data
  - » “FrameBuilder”
- **Networking infrastructure**
- **Interferometer Supervisory Controls**
- **Control Room Equipment**
- **Timing System**
- **Mass Storage Systems**
- **Diagnostics Monitoring and Test Tools (computers & software)**
- **Control & Data System Test Stand for each Observatory**



# DAQ Block Diagram

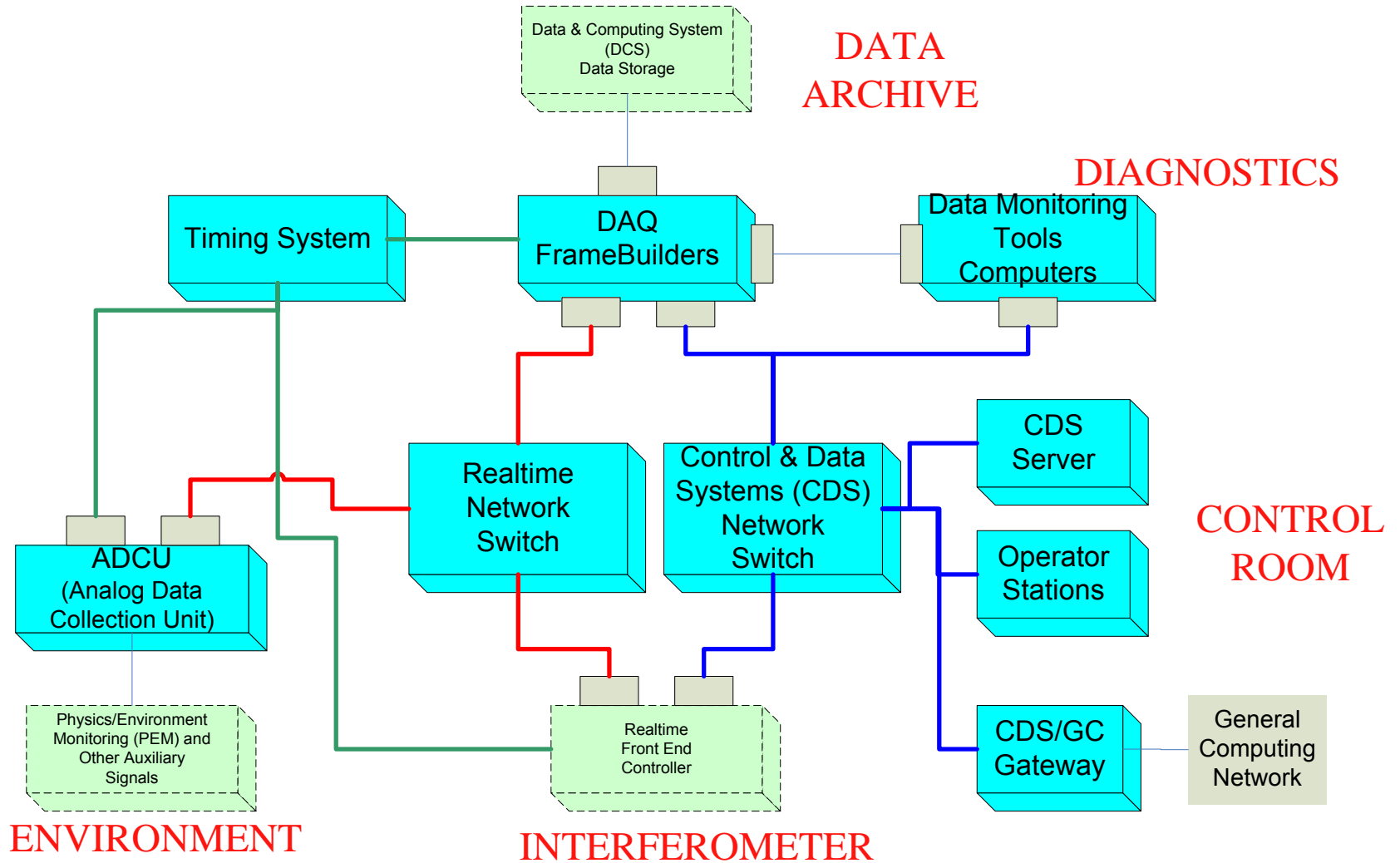

- **Data Archival**
  - » 30 Mb/s raw data rate for 3 interferometers
    - 1.8 PB/year storage (3 copies)
  - » Data striped across disks in cluster (RAID)
    - 10 TB per node – 14.5 PB aggregate
  - » Utilize existing tape robots (with upgrades) for “salt mine” archive
- **Data Distribution**
  - » Existing LIGO WAN expected to handle AdL bandwidth
  - » Infrastructure built on grid technology
- **Computing**
  - » Require ~5 TFLOPS, or ~10 x Initial LIGO FLOPS
    - Longer templates for compact object binary inspiral detection using Weiner filtering techniques
  - » Planned Configuration is ~10 x existing
    - Planned: 23K+ CPUs, >51 THz, 1456 nodes, >10 Gbps switch, SMP data servers
    - Current: 2.3K CPUs, 5.6 THz



# Seismic Isolation: Multi-Stage Solution

- **Render seismic noise a negligible limitation to GW searches**
  - » Both suspension and isolation systems contribute to attenuation
  - » Newtonian background will dominate for frequencies less than ~15 Hz
- **Reduce actuation forces on test masses**

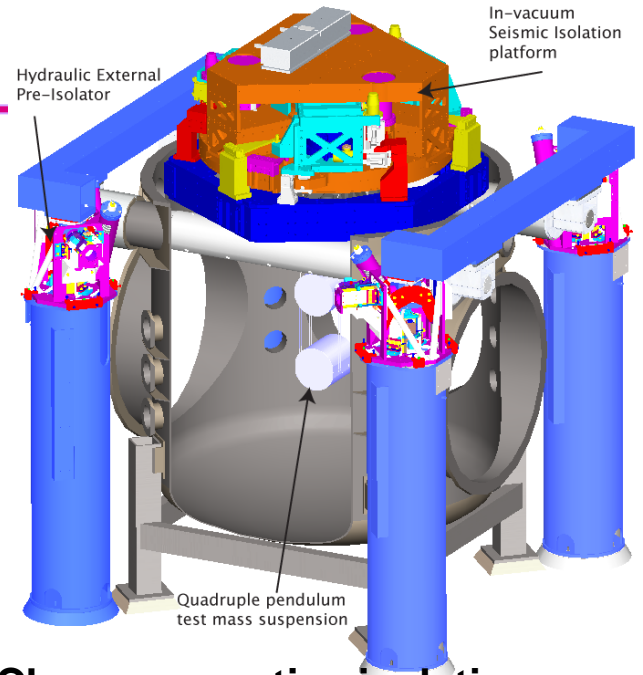
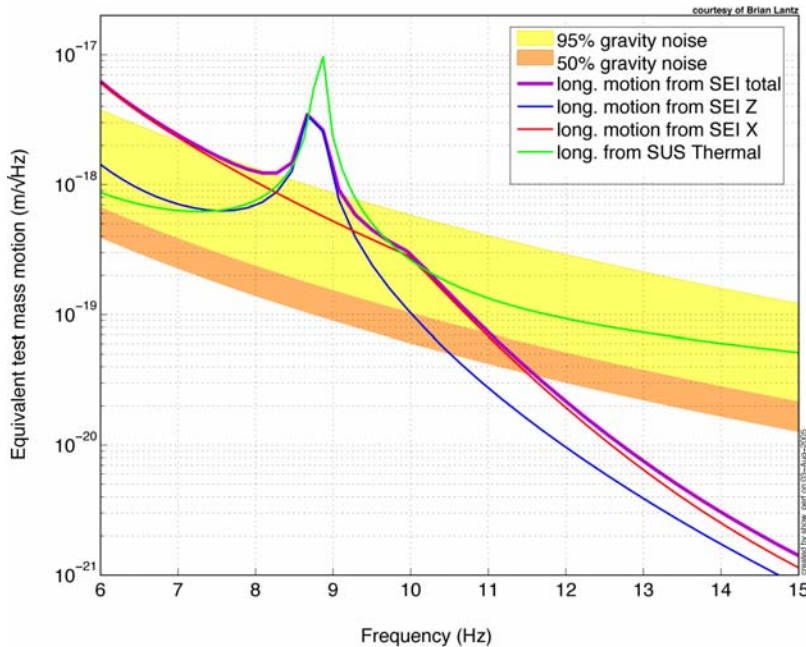

- **Choose an active isolation approach:**
  - » 3 stages of 6 degree-of-freedom each
  - » Hydraulic External Pre-Isolation (HEPI)
  - » Two Active Stages of Internal Seismic Isolation
- **Increase number of passive isolation stages in suspensions**
  - » From single suspensions in initial LIGO to quadruple suspensions<sub>9</sub> for Adv. LIGO

- **BSC Chamber Design**
  - » Full Scale Prototype is being assembled at LASTI
  - » Installation & Test this year with Quadruple Pendulum Suspension Prototype
  - » Modeling based on ~2/3 Scale “Technology Demonstrator” at Stanford’s Engineering Test Facility (ETF) indicates Performance Meets Requirements
- **HAM Chamber design**
  - » Modeling indicates a Single Stage Internal Seismic Isolation (ISI) System meets Requirements
  - » Full Scale Design to be completed for LASTI Prototype

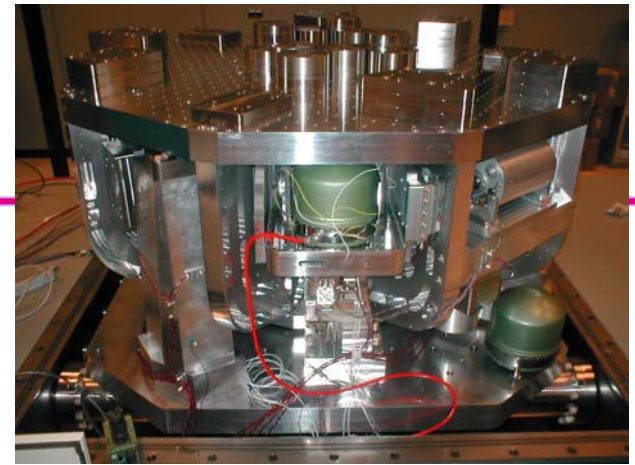

SEI Technology Demonstrator at the Stanford Engineering Test Facility (ETF)

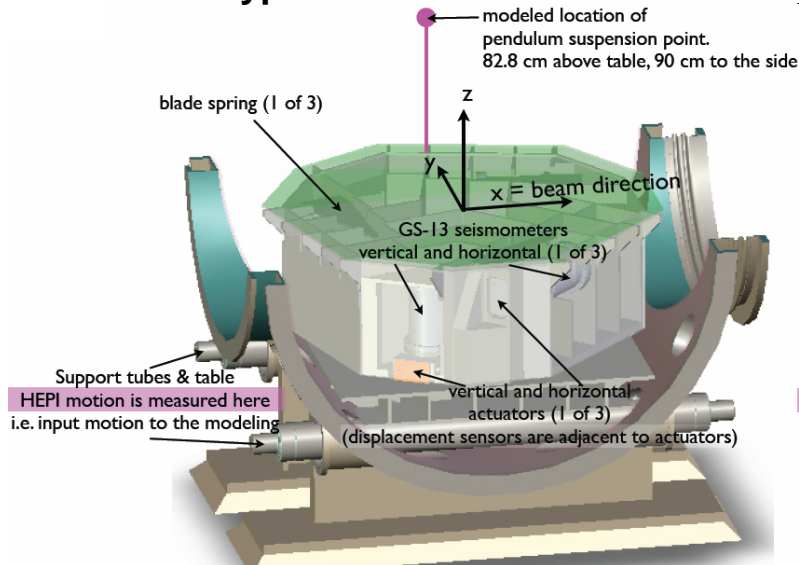

Requirement	HAM Chamber Value	BSC Chamber Value
Payload mass	510 kg	800 kg
Range	$\pm 1 \text{ mm}, \pm 0.5 \text{ mrad}$	$\pm 1 \text{ mm}, \pm 0.5 \text{ mrad}$
Optics table noise	$4 \times 10^{-11} \text{ m}/\sqrt{\text{Hz}}$ (@10 Hz)	$3 \times 10^{-13} \text{ m}/\sqrt{\text{Hz}}$ (@10 Hz)
Angular noise	100 nrad RMS	10 nrad RMS

# Seismic Isolation, HEPI Subsystem Installation at LIGO Livingston Observatory

Coarse & Fine (PEPI) Actuation Systems

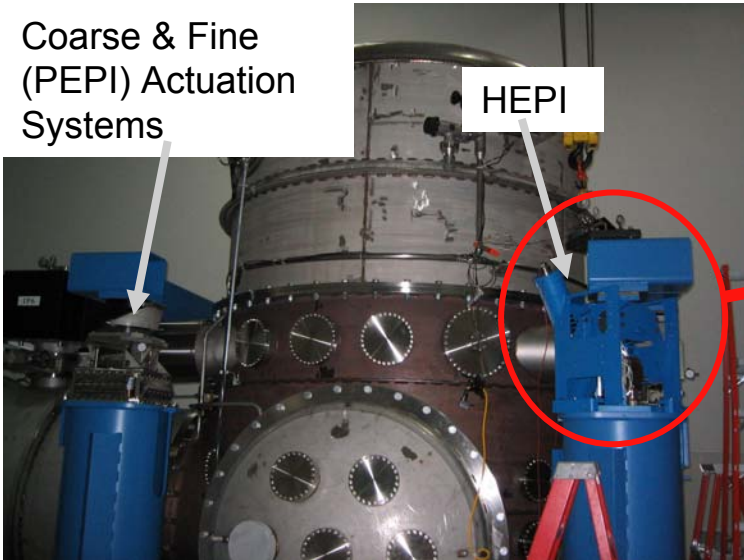

HEPI

Horizontal Actuator

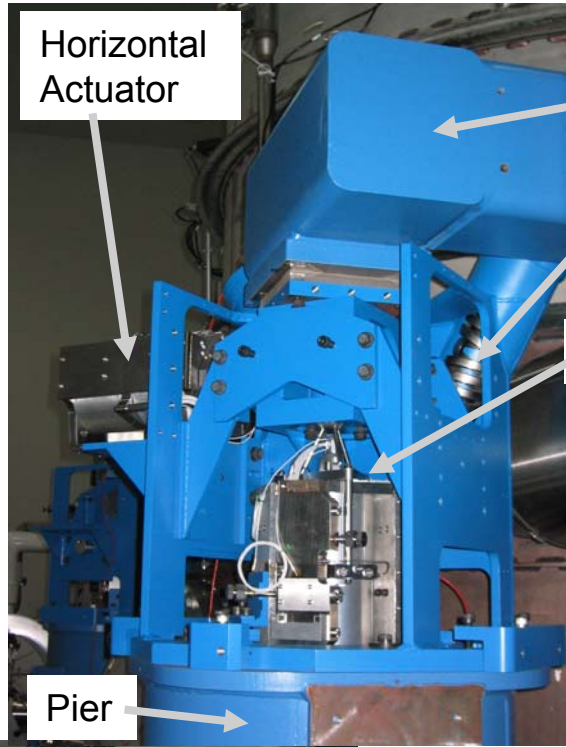

Crossbeam

Helical Spring (1 of 2)

Vertical Actuator

Pier

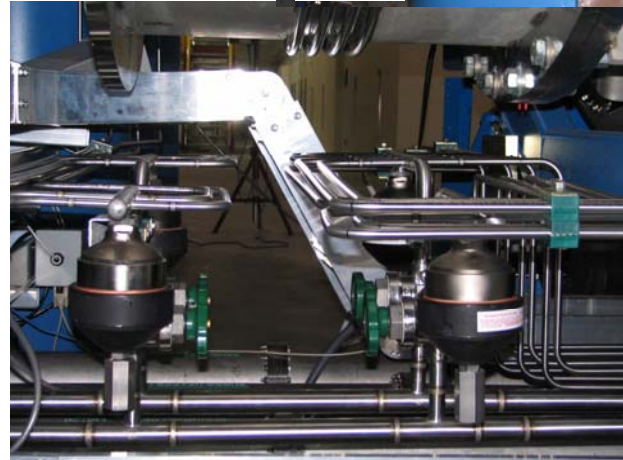

# Thermal Noise Suppression Suspension Subsystem (SUS) Design

- Minimize noise from damping controls and global control actuation
- Minimise thermal noise from pendulum modes
  - » Thermally induced motion of the test masses sets the sensitivity limit in the range  $\sim 10 - 100$  Hz
  - » Required noise level at each of the main optics is  $10^{-19}$  m/ $\sqrt{\text{Hz}}$  at 10 Hz, falling off at higher frequencies

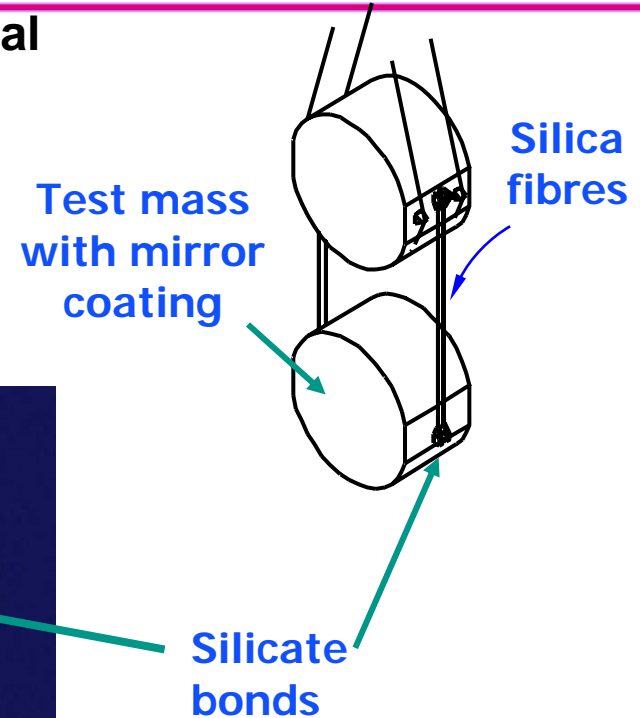
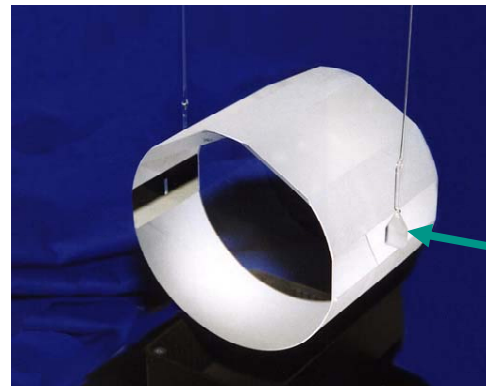
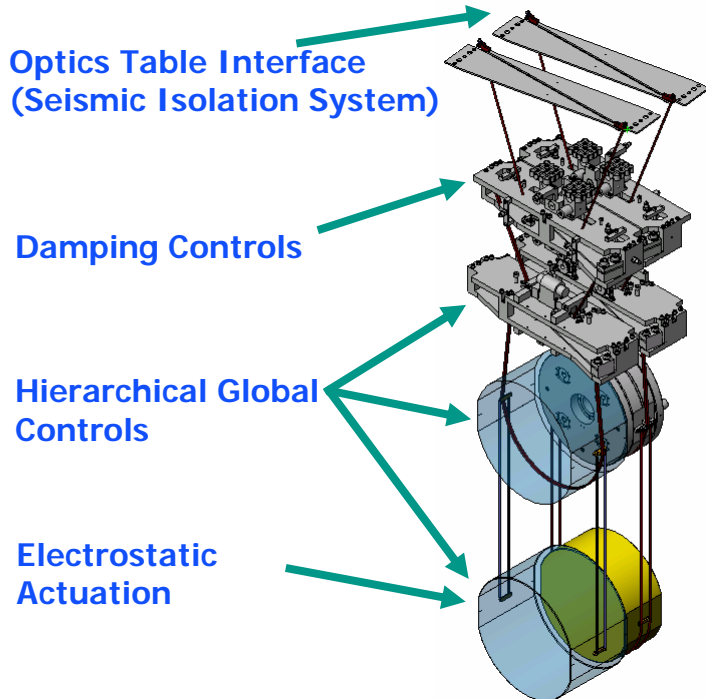

- Choose **quadruple** pendulum suspensions for the main optics and **triple** pendulum suspensions for less critical cavity optics
- Create quasi-monolithic pendulums using fused silica ribbons to suspend 40 kg test mass

# Suspensions Update

(Combined US and UK Effort)

- **Test Mass (Quad) Suspension**

- » ‘Controls’ Prototype installed at LASTI & under Test
- » Preliminary Results in June for Concurrent “Noise” Prototype Development
- » The UK Group delivers the “Noise” Prototype (essentially final design) in early 2007

Quad Suspension in LASTI BSC Chamber

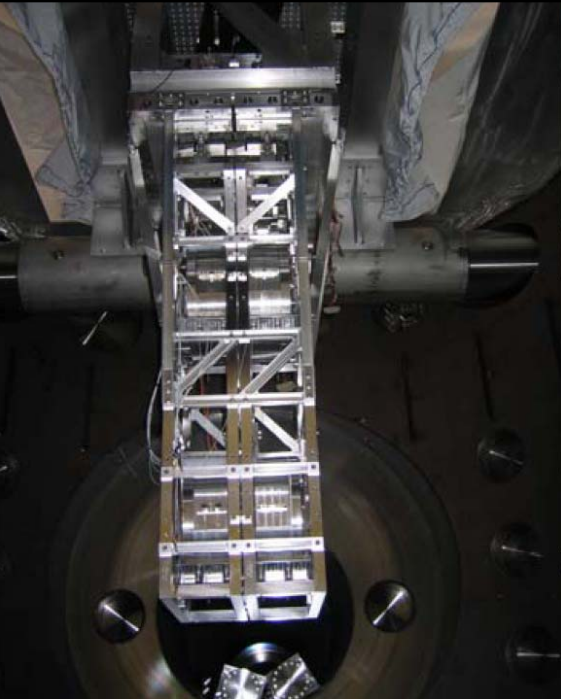

Triple Suspension in LASTI HAM Chamber



- **Mode Cleaner (Triple) Suspension**

- » LASTI Testing of controls prototype completed
- » Performance as expected
- » Model-measurement comparison caught some model shortcomings & an as-built difference
- » Final “Noise” Prototype is next

- **Other suspensions (extensions of existing designs):**

- **Recycling mirror (triple) –full design**
- **Beamsplitter (triple) –conceptual design**
- **Folding Mirror (triple) –conceptual design**
- **Output mode cleaner (double) –conceptual design underway**
- **Mode matching telescopes, steering mirrors etc (single) –**  
**modified LIGO 1 suspensions**

- **Silica Fiber/Ribbon Pulling**

- » R&D on computer controlled CO<sub>2</sub> laser system proceeding well
- » Fibers up to 570 mm long,  $184 \pm 5$  microns diameter (15 microns dia. repeatability)
- » 3 GPa breaking stress (factor of safety  $\approx 4$ )

- **Fiber/Ribbon Welding**

- » Fiber & ribbon welding demonstrated
- » Working to improve welded strength

- **Electronics**

- » Improved Optical Sensing & Electro-Magnetic actuator (OSEM) assembly
- » New Control & Data Systems (CDS), Bus & Network Topology at LASTI implemented to support Seismic & Suspension Prototype Testing

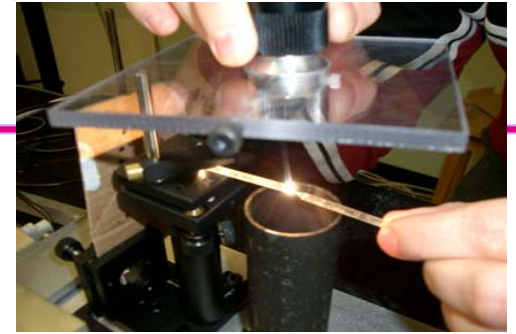

Welding 3mm silica rod with 9W CO<sub>2</sub> laser

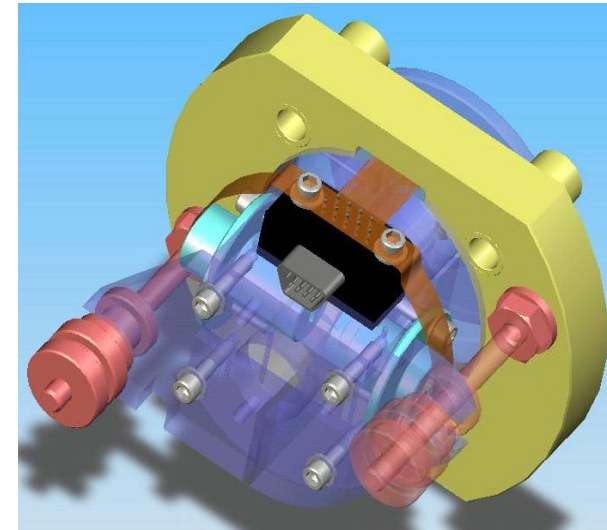

Modified Hybrid  
OSEM Design

- **Systems Engineering is Level-Of-Effort in the Construction Phase**
- **Maintain Interface Control Documentation (ICD)**
- **Continue Modeling/Simulation**
- **Maintain technical configuration management**
- **Define integrated test plans & procedures**
- **Review/Approve Subsystem acceptance test plans, test reports, EMI/EMC & grounding implementation, ...**

•3D, Integrated Opto-mechanical layout captured in SolidWorks CAD

•Optical layout defined with Zemax

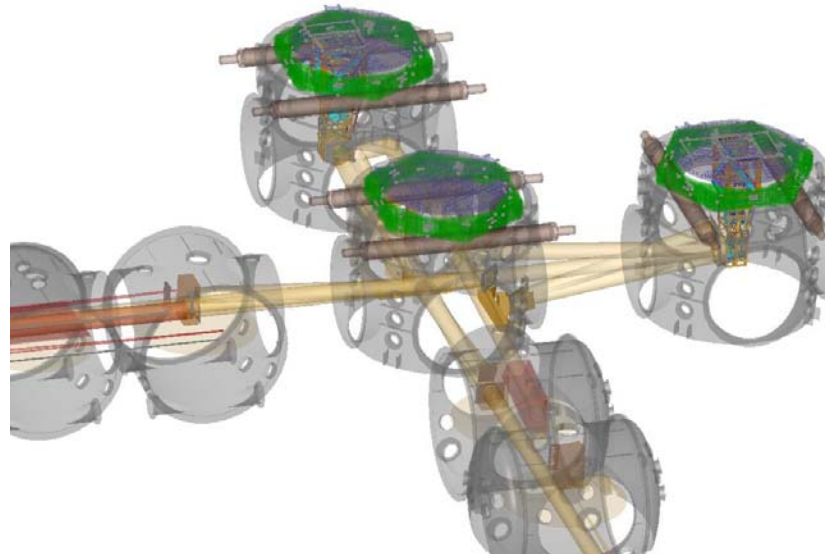

- **Plan for Installation, Logistics and Staging**
- **Procure new Vacuum System components**
  - » 2K to 4K conversion
  - » large diameter mode cleaner tubes
  - » Relocation of 2 HAM chambers for each interferometer
- **Procure more class 100 clean room space for assembly and installation**
- **Provide assembly workspace and storage**
- **Procure installation fixtures and tooling**
- **Refurbish existing optics lab space, purchase bake oven, cleaning supplies**



- **Basic Task Sequence per Interferometer:**

- » Removal
- » Vacuum Equipment & Infrastructure Modifications
- » Installation
- » Testing

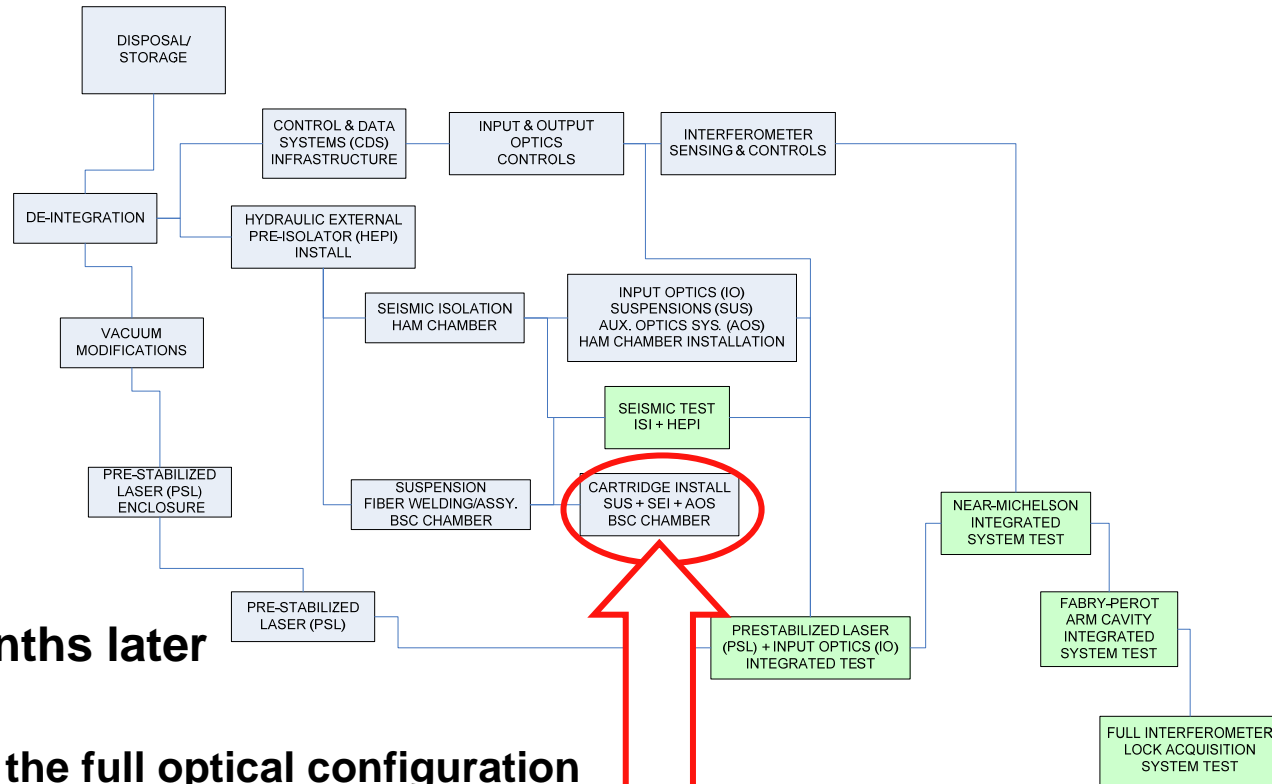

- **Start at Livingston**
- **Hanford starts ~9 months later**
- **Duration is ~3 years**
  - » **Multi-hour “lock” in the full optical configuration for all 3 interferometers**
  - » **Transition to operations as Subsystems and Interferometers are Accepted**

**@LASTI  
next page**

